

Appendix A. Wiring details

A.1 Parts

A.1.1 Pressure transducers

The differential pressure transducers used were Honeywell 0 psid to 1 psid ASCX01DN. The pressure transducers have six pins (labeled 1 to 6 on the device) for connecting wires and two ports (A and B) for connecting tubing. The pins needed for this method were pins 2, 3, and 4. The other pins do not need to be connected to anything. Pin 2 is connected to a positive voltage, pin 3 is connected to the data logger's white wire, and pin 4 is connected to a ground.

Port A is connected to the upper hole in the infiltrometer (see Methods), and port B is connected to the lower hole. Water does not enter the tubing or the ports, and the pressure transducer is not designed to have its ports measure water pressure.

Although the pressure transducers are capable of producing a voltage above 2.5 V (which is the maximum that the data logger can accept), a pressure differential high enough to do so was never generated during this study.

A.1.2 Wiring parts

Because it was not desirable to solder wires directly onto the pressure transducer pins, IC sockets were used to fit over the pins. The specific socket used was a RadioShack 276-1995, an eight-pin socket. The plastic joining the socket together in the middle was cut, leaving two four-pin sockets. These sockets fit over pins 1, 2, 3, and 4 of each pressure transducer.

Barrier strips were used so that one battery could power all four pressure transducers at once. The specific barrier strip was an LKG Industries 13-1404, a four pole barrier strip.

A bus (BEAU 7233, cut in half to yield two shorter buses) was inserted on one side of each of the barrier strips.

22 AWG insulated copper wire, which contained red and black wire inside of a gray outer casing, was used for connecting the pressure transducers and barrier strips. The other casing was removed. About 1 meter of wire (0.5 meter red and 0.5 meter black) was necessary to make all the connections.

Alligator clips were used to connect and disconnect the battery from the pressure transducers. The specific clips used were RadioShack 270-356, 2 red and 2 black fully insulated clips. 15 cm of wire was used to connect the red clips to each other and the black clips to each other.

The battery used was an Eveready super heavy duty six volt battery. However, any six volt battery should be sufficient.

A.1.3 Data logger

The data logger was a HOBO 4 external channel logger, U12-006. Four stereo cables (part number “Cable-2.5-stereo”) were connected to each of the four channels of the data logger. Each cable contained three wires: switched 2.5 V output (red) used to power a sensor, voltage input (white), and ground (black). The red wire was unnecessary, since the data loggers are being powered by the battery.

A.1.4 Packaging

The pressure transducers and barrier strips were mounted on a very thick piece of cardboard with screws. The cardboard was placed inside of a clear plastic flip-top box (approx. 30 cm x 15 cm x 7 cm) (Figure A-1). Holes (.953 cm (3/8”) drill bit) in the side of the box allowed the tubing and USB cord to be connected while the box lid was closed. The battery was placed in a cut out section of the cardboard so that it would not roll around.

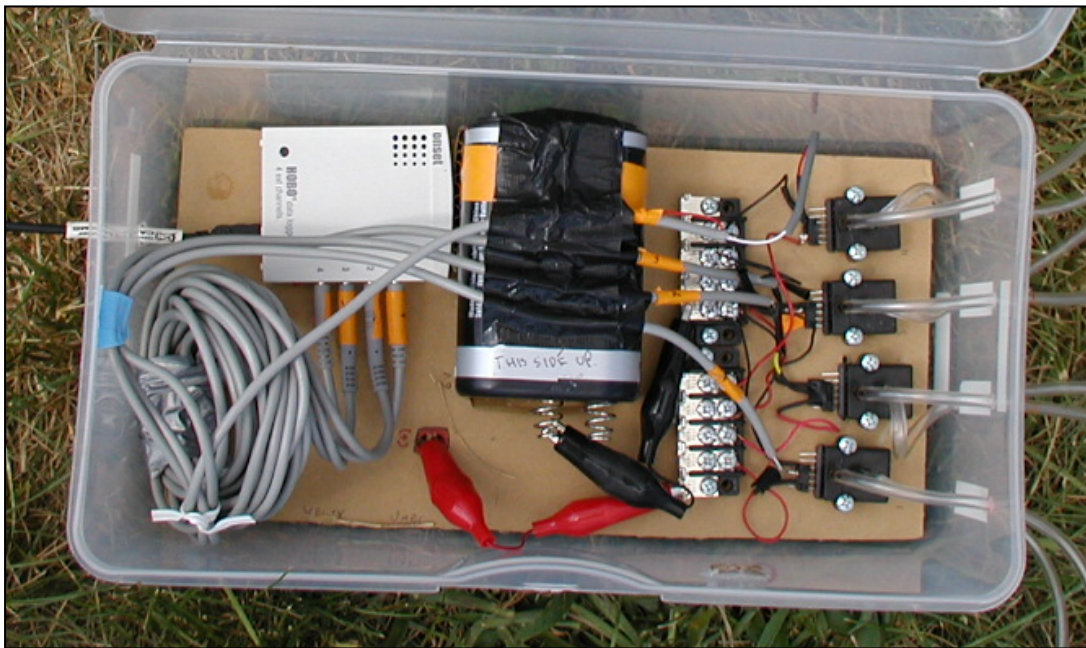

Figure A-1. Layout of wiring components in plastic box.

A.2 Construction

First, three wires were soldered to each of the IC socket halves: an approximately 10 cm long red wire on pin 2, one of the white wires from the data-logger stereo cables on pin 3, and an approximately 10 cm long black wire on pin 4 (pin numbers refer to the corresponding pressure transducer pin). Heat shrink wrap was applied to the red and black wires where they were soldered to the socket so that no contact would occur between the pins.

The other end of each red wire was connected to one of the screws on one of the barrier strips on the opposite side from the bus. The other end of each black wire was connected similarly to

the other barrier strip. In addition, the black grounding wires from the data logger's stereo cables were connected to this barrier strip (under the screws on the side with the bus). Connecting the grounding wires from the data logger completes the circuit to give the data logger a reference for the voltage that it is receiving.

The alligator clips were clipped onto the edge of each bus, with the red set of clips connecting the positive terminal of the battery to the barrier strip two which the red wires were connected and the black set of clips connecting the negative terminal of the battery to the barrier strip with the black wires attached. The clips were disconnected when not making a measurement.

Figure A-2 shows the necessary wiring connections between the data logger and the pressure transducers.

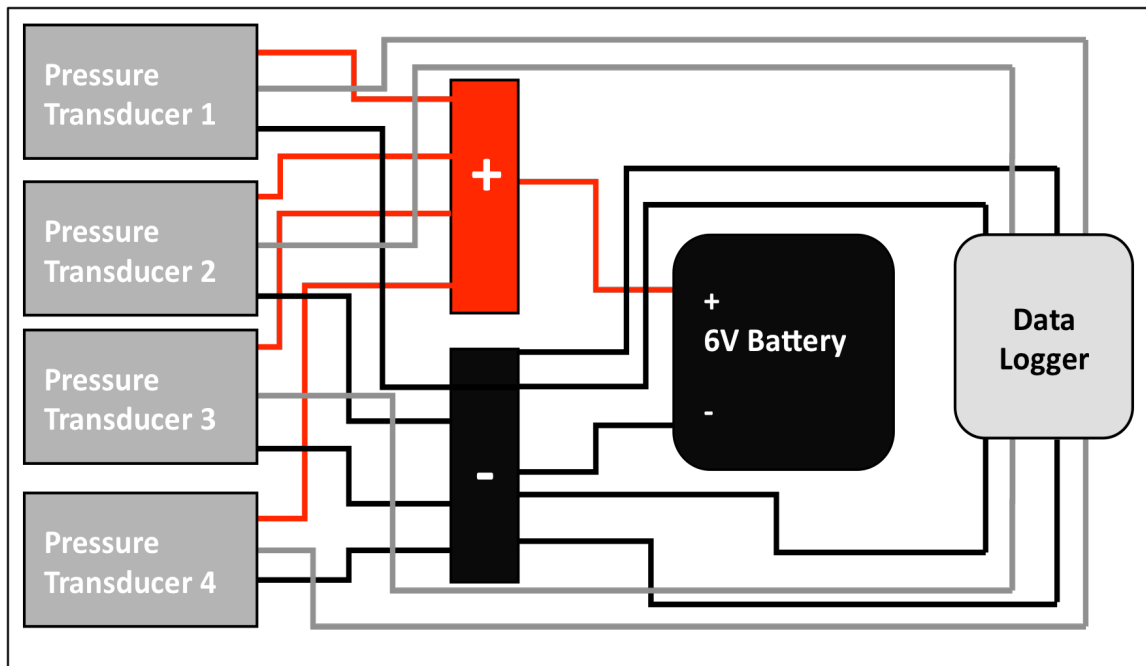

Figure A-2. Diagram of wiring connections.

Appendix B. Summary of sites

The saturated hydraulic conductivity values (Ks) (cm/s), standard deviation (STDEV) (cm/s), and relative standard deviation (RSD) are listed below, along with soil survey data for soil type, texture, and saturated hydraulic conductivity.

<u>Site ID</u>	<u>Mean Ks</u>	<u>STDEV</u>	<u>RSD</u>	<u>Soil Type</u>	<u>Soil Survey Texture</u>	<u>Soil Survey Ks (cm/s)</u>
D1	3.4E-03	1.4E-04	4.1%	Tidal Marsh; Tm*	--	1.0E-05 – 7.0E-05
D6	2.0E-03	2.5E-04	12%	Brandywine; ByD2	Loam	1.400E-03 – 4.200E-03
D8	1.7E-03	2.0E-04	11%	Loamy and Clayey; LyB	Sandy Loam	4.200E-03 – 1.4100E-02
D14	2.5E-04	2.2E-04	88%	Glenelg; GcB2	Loam	4.00E-04 – 1.400E-03
D27	1.0E-03	3.9E-04	38%	Hatboro; Hb	Silt Loam	4.00E-04 – 1.400E-03
D40	6.6E-04	2.2E-04	33%	Manor; MbC2	Loam	4.00E-04 – 1.400E-03
D42	1.3E-03	3.3E-04	26%	Glenelg; GcC3	Loam	4.00E-04 – 1.400E-03
D56	1.6E-03	1.5E-04	9.5%	Manor; MbB2	Loam	4.00E-04 – 1.400E-03
D61	5.4E-03	2.0E-04	3.7%	Chester; CcB2	Silt Loam	4.00E-04 – 1.400E-03
D75	4.2E-04	3.4E-04	80%	Manor; MbC3	Loam	4.00E-04 – 1.400E-03
D77	1.8E-03	1.4E-04	7.8%	Hagerstown; HaB2	Silt Loam	4.00E-04 – 4.200E-03
D90	1.9E-03	**	**	Glenelg; GcC2	Loam	4.00E-04 – 1.400E-03
W1	3.5E-03	3.5E-04	9.9%	Udorthents; 38C	Clay Loam	1.40E-04 – 4.00E-04
W2	8.3E-04	3.0E-04	36%	Udorthents; 42E	Sandy Loam	1.400E-03 – 4.200E-03
W3	1.8E-03	1.7E-04	9.3%	Udorthents; 40C	Sandy Loam	4.2E-05 – 4.00E-04
W4	8.3E-03	2.7E-04	3.2%	Sunnyside; 35C	Sandy Loam	4.00E-04 – 1.400E-03
				Aldino/ Urban Land/ Unnamed Soils/ Watchung; AuB	Silt Loam -- -- Silt Loam	4.00E-04 – 4.200E-03 -- -- 1.40E-04 – 1.400E-03
				Legore/ Urban Land/ Unnamed Soils/ Montalto/ Relay; 18UC	Loam -- -- Silt Loam Silt Loam	4.00E-04 – 4.200E-03 -- -- 4.00E-04 – 4.200E-03 4.00E-04 – 1.400E-03
W9	1.2E-03	1.8E-04	15%			
W10	4.3E-04	2.7E-04	63%	Aldino/ Watchung; AdB2	Silt Loam Silt Loam	4.00E-04 – 4.200E-03 1.40E-04 – 1.400E-03
				Legore/ Urban Land/ Unnamed Soils; LhC	Silt Loam -- --	4.00E-04 – 4.200E-03 -- --
W11	7.1E-04	2.0E-04	29%			
W12	4.4E-04	2.5E-04	57%	Legore; 18C	Silt Loam	4.00E-04 – 4.200E-03
				Legore/ Urban Land/ Jackland/ Montalto/ Relay/ Unnamed Soils;18UB	Loam -- Silt Loam Silt Loam Silt Loam --	4.00E-04 – 4.200E-03 -- 4.00E-04 – 1.400E-03 4.00E-04 – 4.200E-03 4.00E-04 – 1.400E-03 --
W13	3.1E-04	1.3E-04	44%			
W14	2.8E-04	2.3E-04	81%	Udorthents; 39E	Loam	4.2E-05 – 4.00E-04

W16	6.1E-04	1.8E-04	30%	Legore/ Urban Land/ Unnamed Soils; LhB	Silt Loam -- --	4.00E-04 – 4.200E-03 -- --
W19	7.5E-04	1.6E-04	22%	Watchung; WaB	Silt Loam	1.40E-04 – 1.400E-03
W21	1.1E-03	2.5E-04	24%	Aldino/ Watchung	Silt Loam Silt Loam	4.00E-04 – 4.200E-03 1.40E-04 – 1.400E-03
W22	4.8E-04	1.8E-04	38%	Kelly/ Watchung; KeB2	Silt Loam Silt Loam	4.00E-04 – 1.400E-03 1.40E-04 – 1.400E-03
W25	1.3E-03	1.2E-04	9.3%	Montalto; MsB2	Silt Loam	4.00E-04 – 4.200E-03
W26	1.5E-04	1.2E-04	78%	Baile, BaA	Loam	1.40E-04 – 4.00E-04
W27	5.4E-04	1.9E-04	35%	Hatboro; Hb	Silt Loam	4.00E-04 – 1.400E-03
W28	8.4E-04	1.6E-04	19%	Manor; McD2	Loam	4.00E-04 – 1.400E-03
W30	9.9E-04	2.3E-04	23%	Glenville; GnB	Silt Loam	4.00E-04 – 1.400E-03
W31	4.7E-04	3.1E-04	66%	Glenville/ Baile; GnB	Silt Loam Silt Loam	1.20E-04 – 1.40E-04 1.20E-04 – 1.40E-04
W33	1.3E-04	1.3E-04	94%	Manor; MbC2	Loam	1.10E-04 – 1.40E-04
W34	1.1E-03	1.1E-04	10%	Manor; MbB2	Loam	1.10E-04 – 1.40E-04
W37	5.2E-04	1.2E-04	23%	Glenelg; GcC2	Loam	4.00E-04 – 1.400E-03
W38	1.4E-03	4.8E-04	34%	Hatboro; Hb	Silt Loam	4.00E-04 – 1.400E-03
W40	9.6E-04	2.4E-04	25%	Glenville/ Baile; GnA	Silt Loam Silt Loam	4.00E-04 – 1.400E-03 1.40E-04 – 4.00E-04
W41	3.3E-04	1.3E-04	40%	Glenville/ Baile; BaA	Silt Loam Silt Loam	4.00E-04 – 1.400E-03 1.40E-04 – 4.00E-04
W42	9.5E-03	1.5E-04	1.6%	Baile; BaA	Silt Loam	1.40E-04 – 4.00E-04

*Tidal marsh does not accurately describe this site. Since the soil survey was completed, the area has been turned into a baseball field (See Appendix D).

**Only one measurement at this site was usable.

Appendix C. Tension vs. hydraulic conductivity curves

Below are the hydraulic conductivity as a function of tension equations and the graphed curves of those equations. Graphs were made for each individual measurement, and also for the geometric average and standard deviation of all measurements at a site. Each page lists the site number (corresponding to site names listed in Appendix B). Measurements for which saturated hydraulic conductivity calculations were impossible (see section 5.2) have been omitted, so some sites have fewer than four graphs.

D1. Southwest Area Park

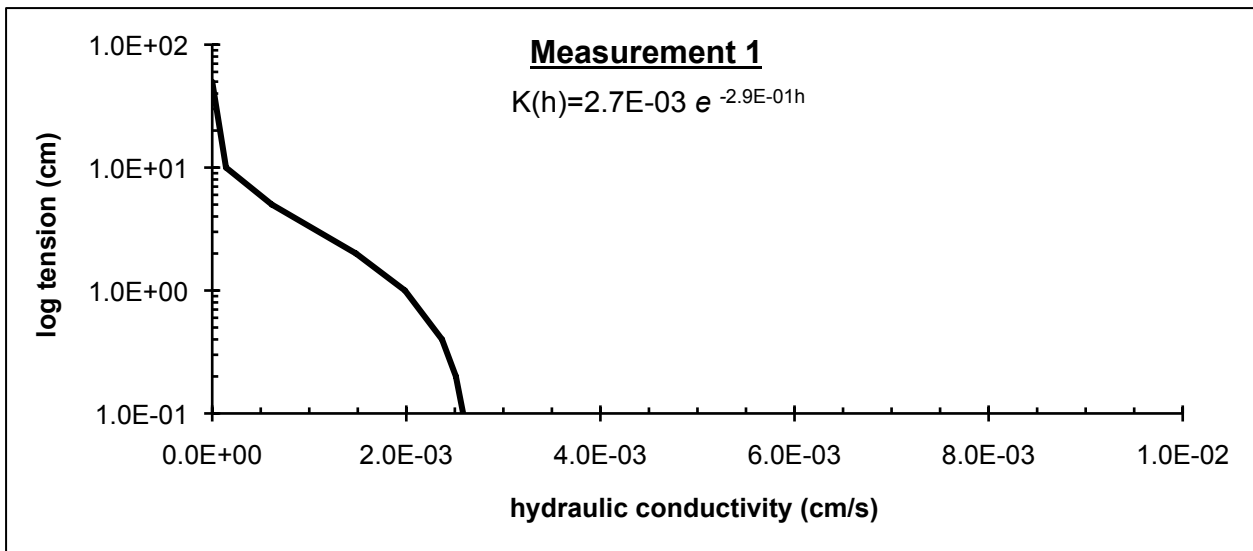
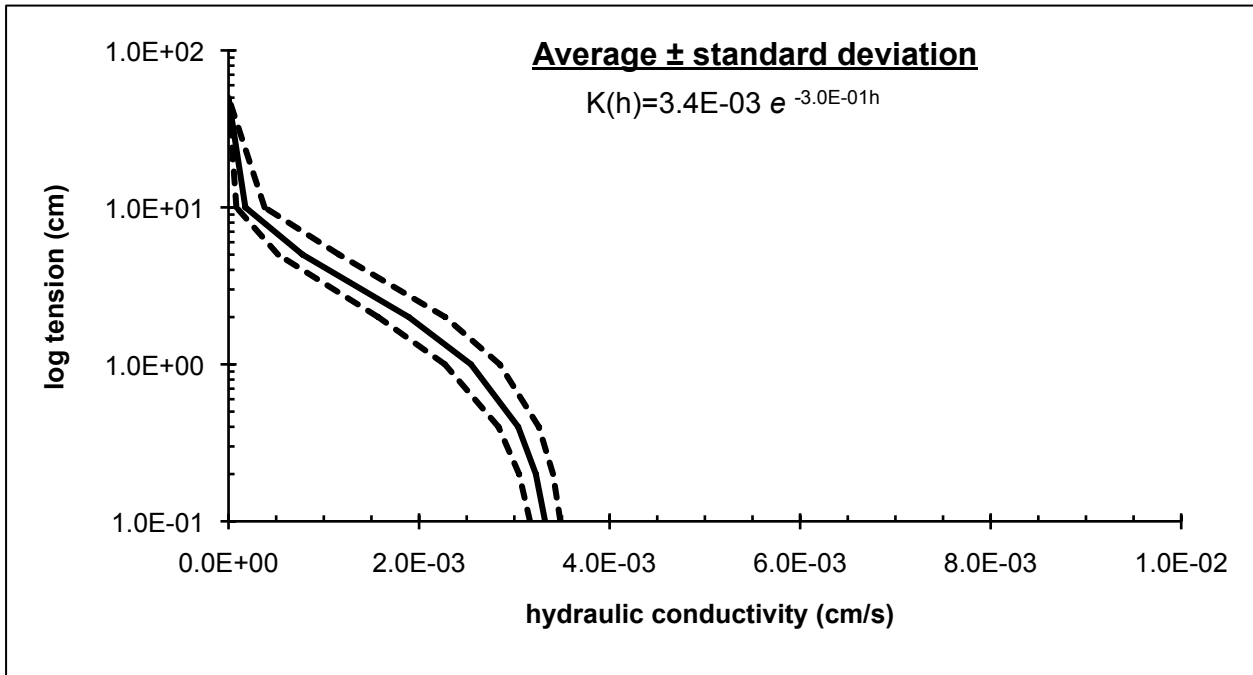

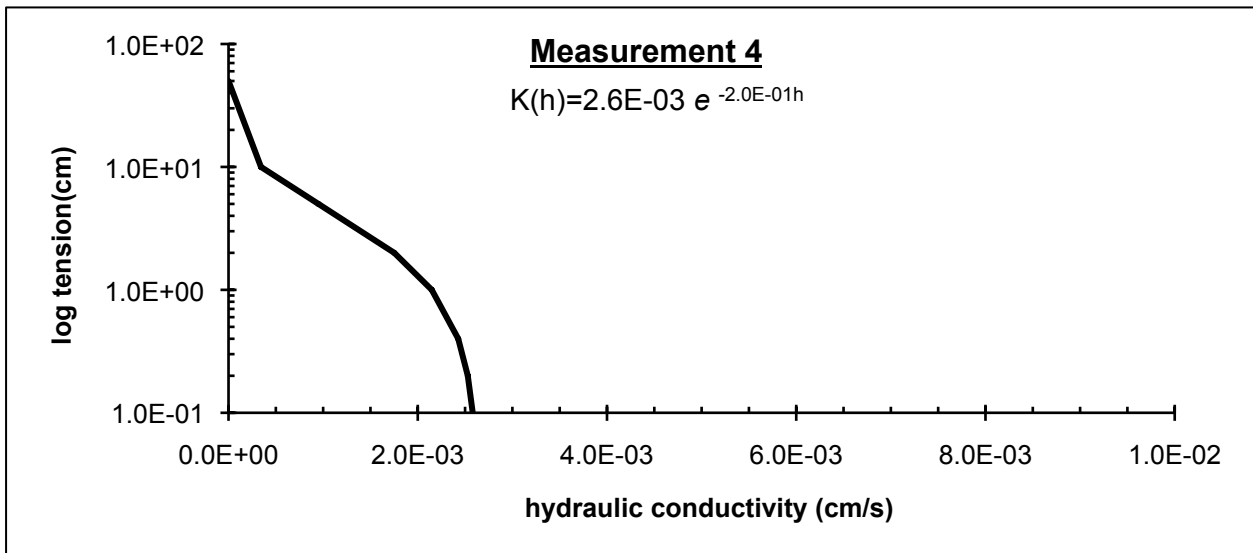
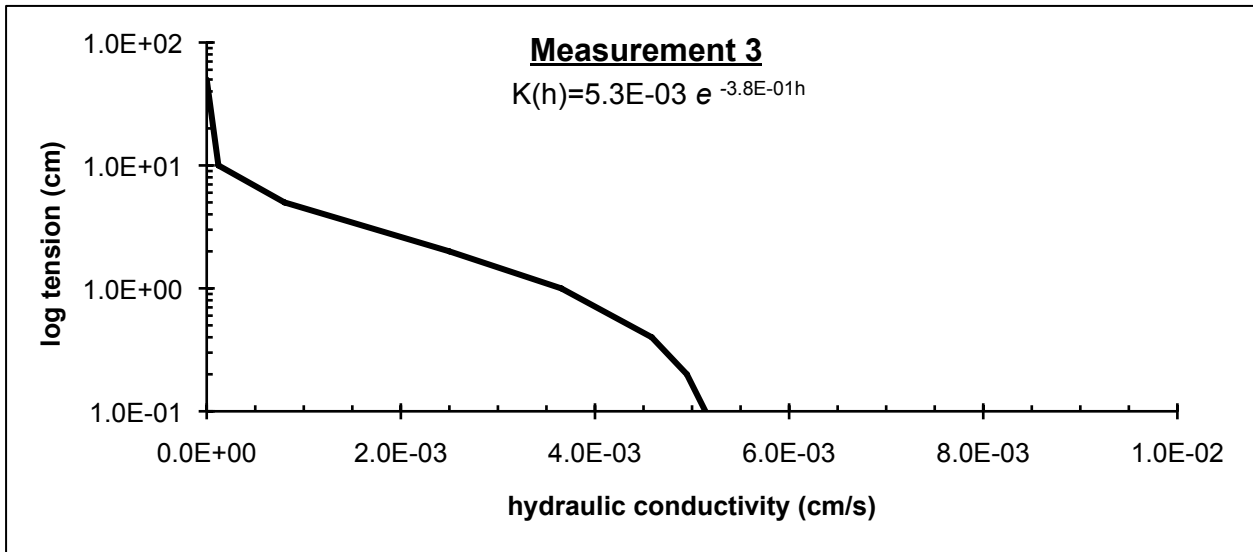
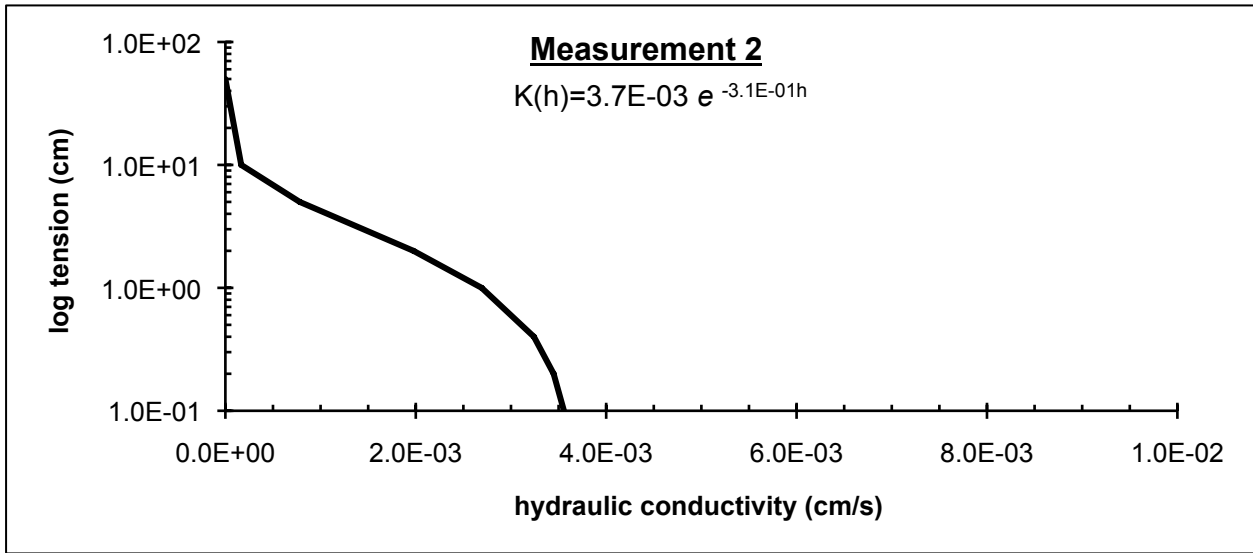

D6. UMBC South Campus

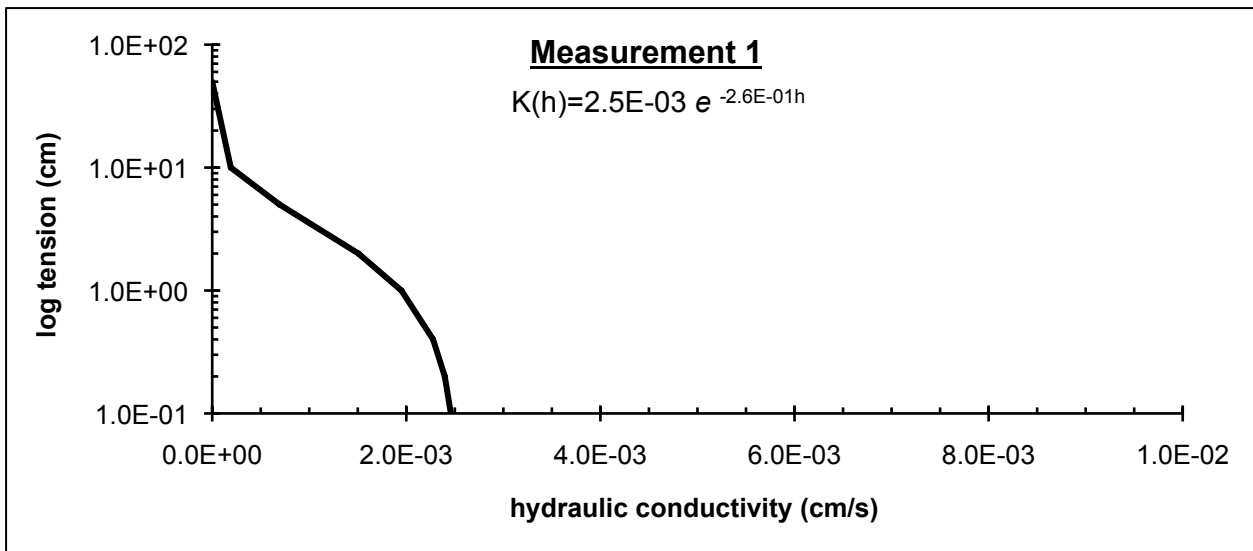
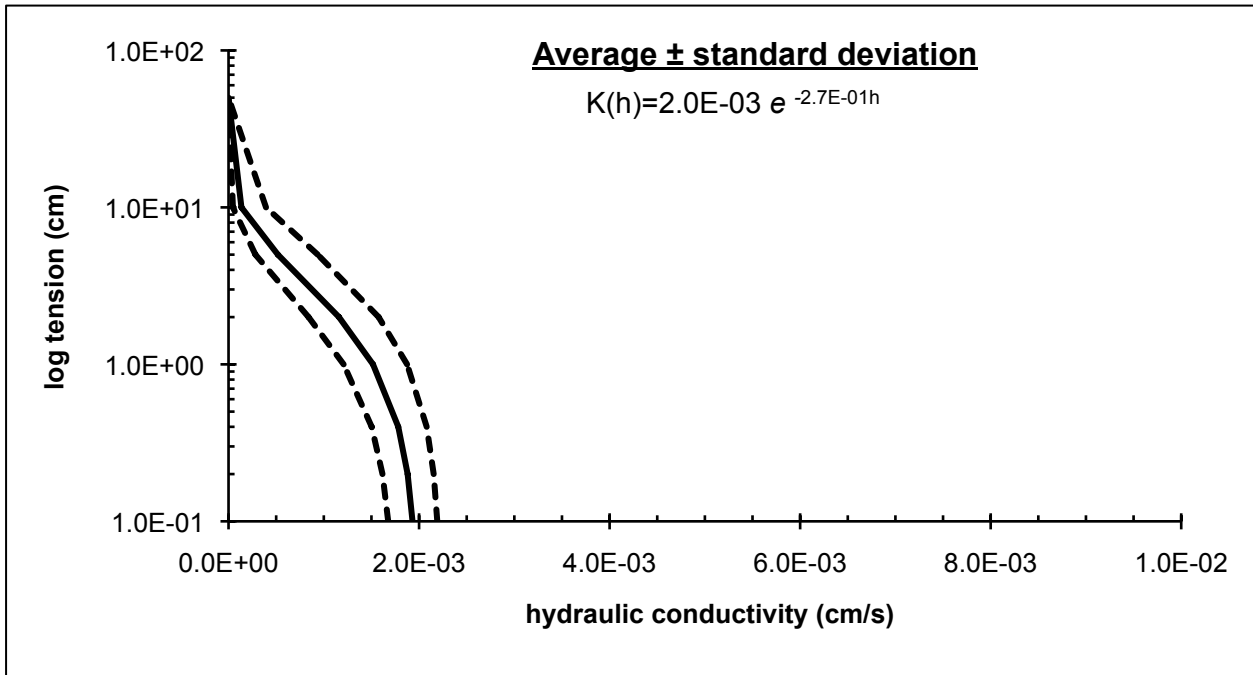

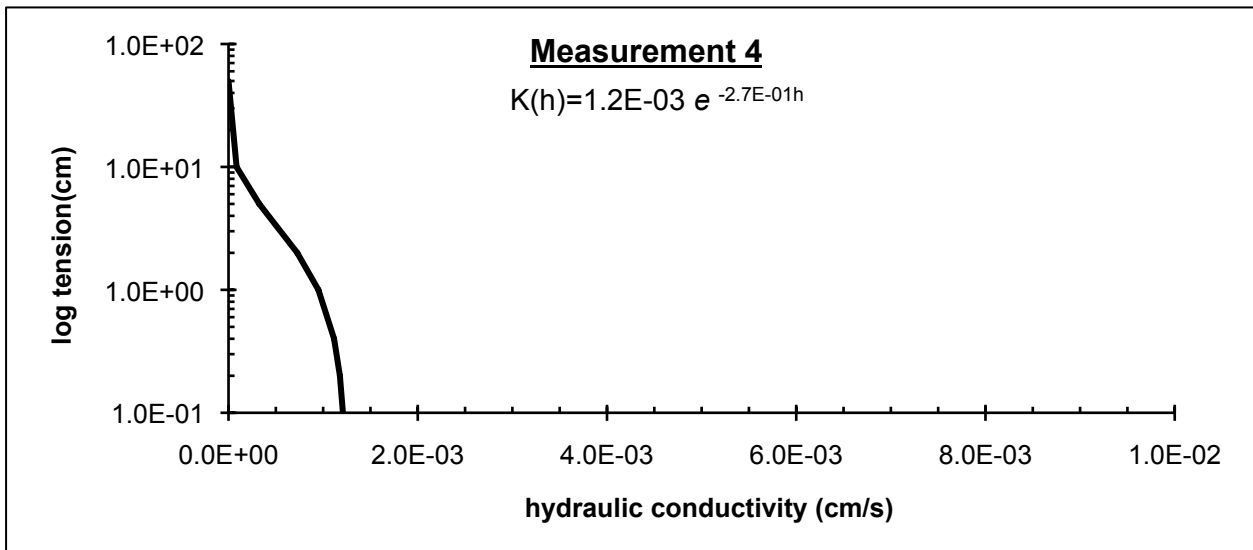
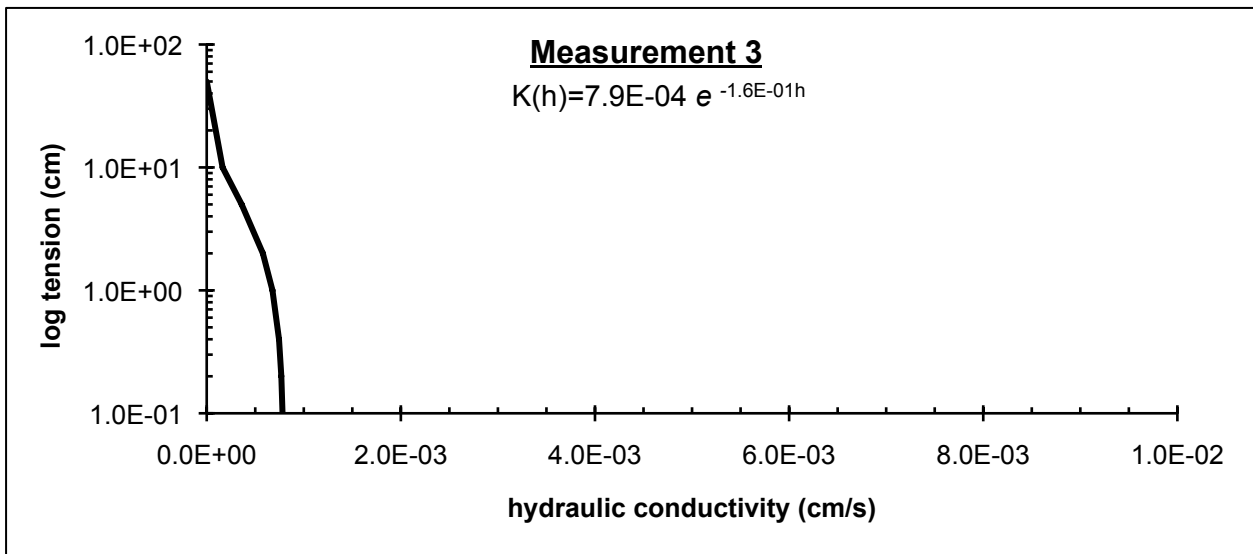
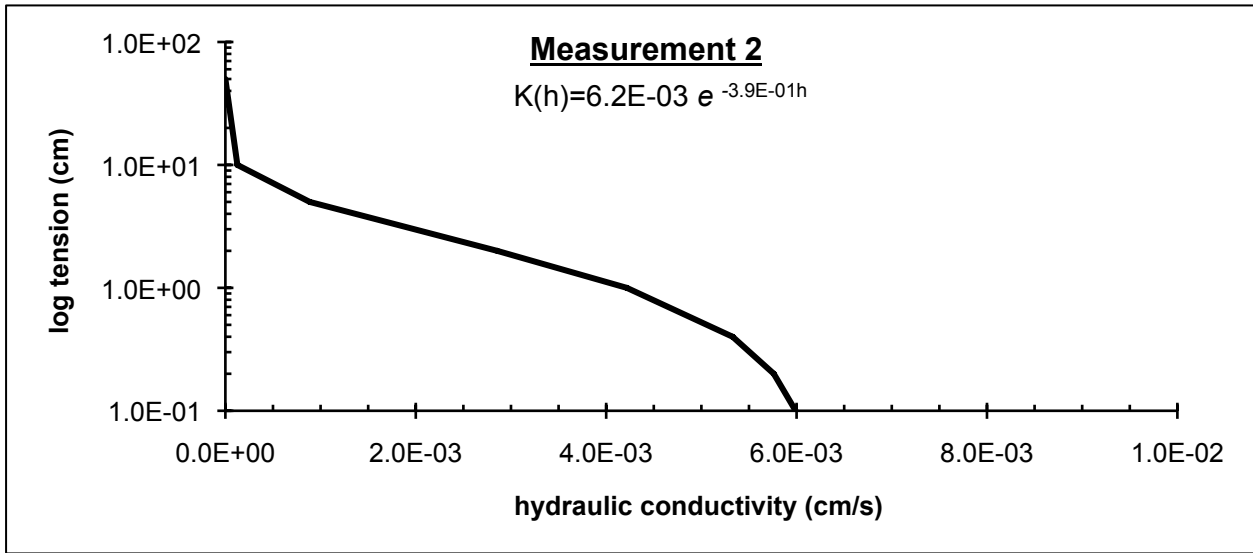

D8. UMBC near athletic fields

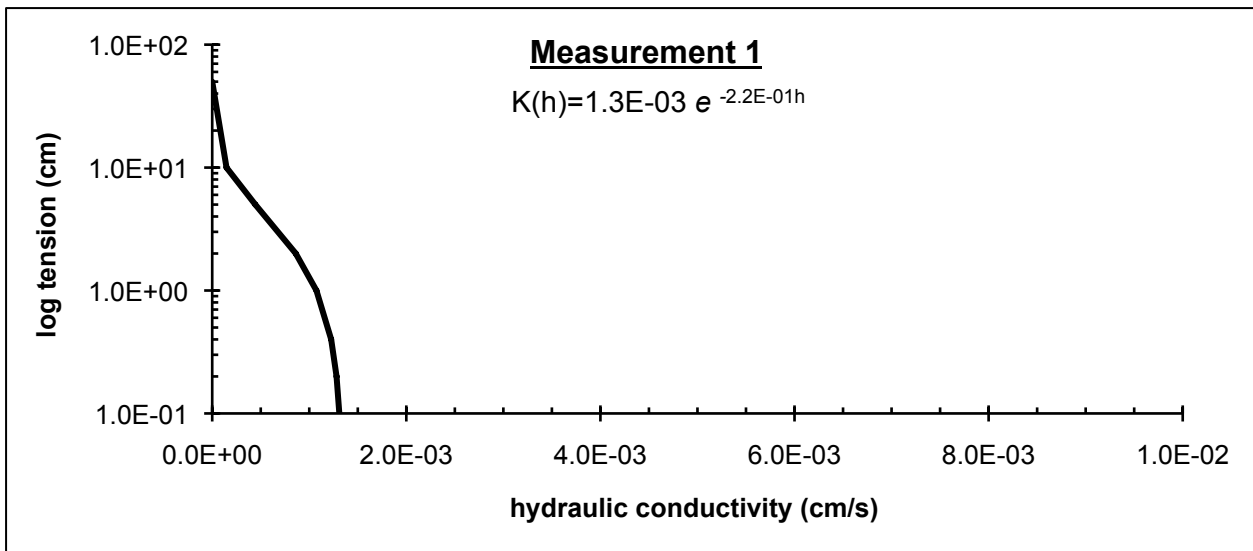
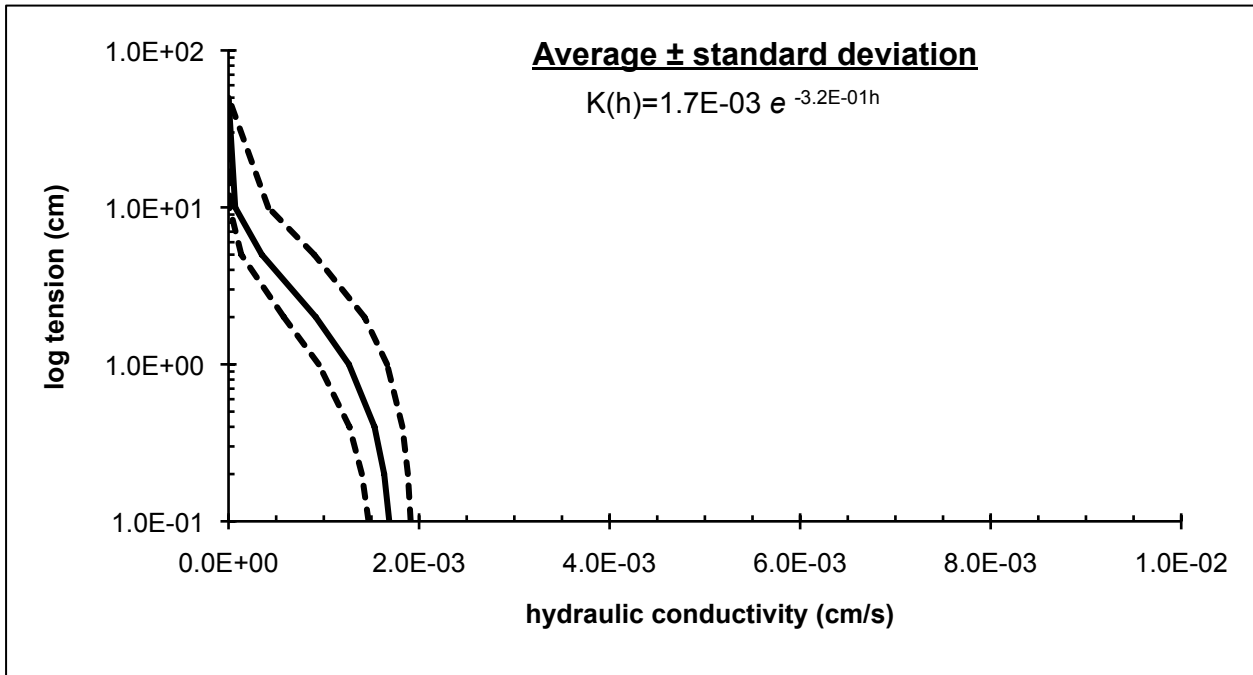

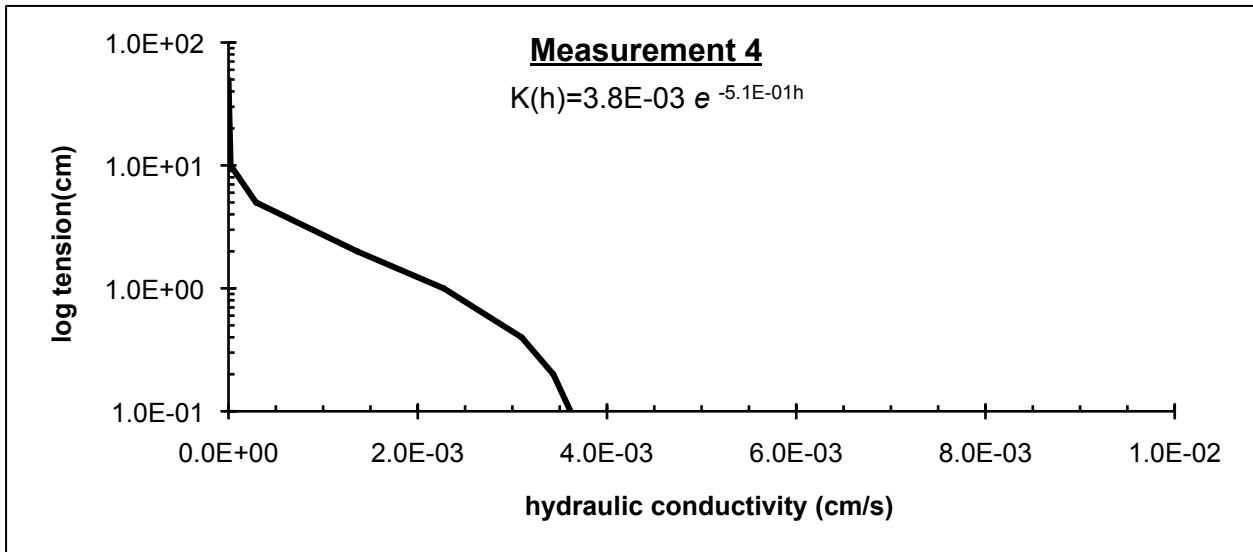
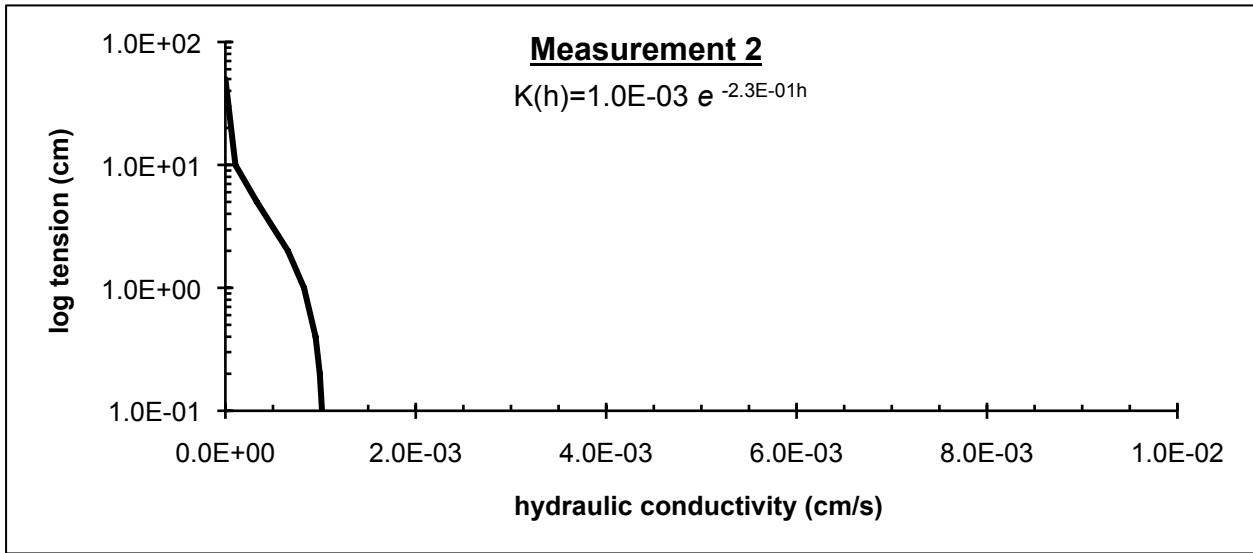

D14. Patapsco State Park at S Hilltop Rd

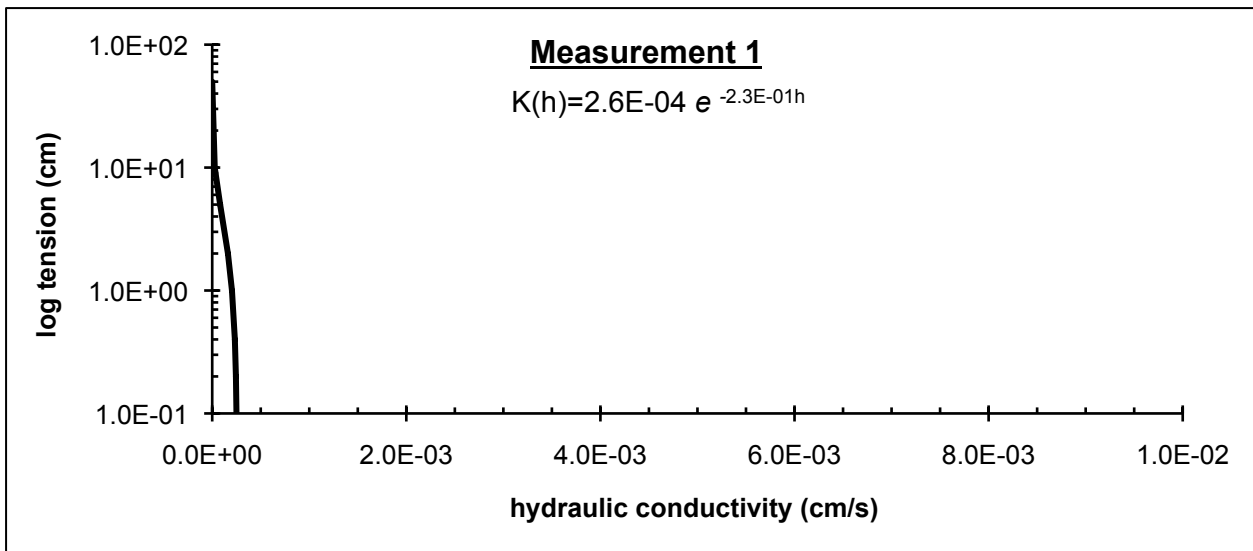
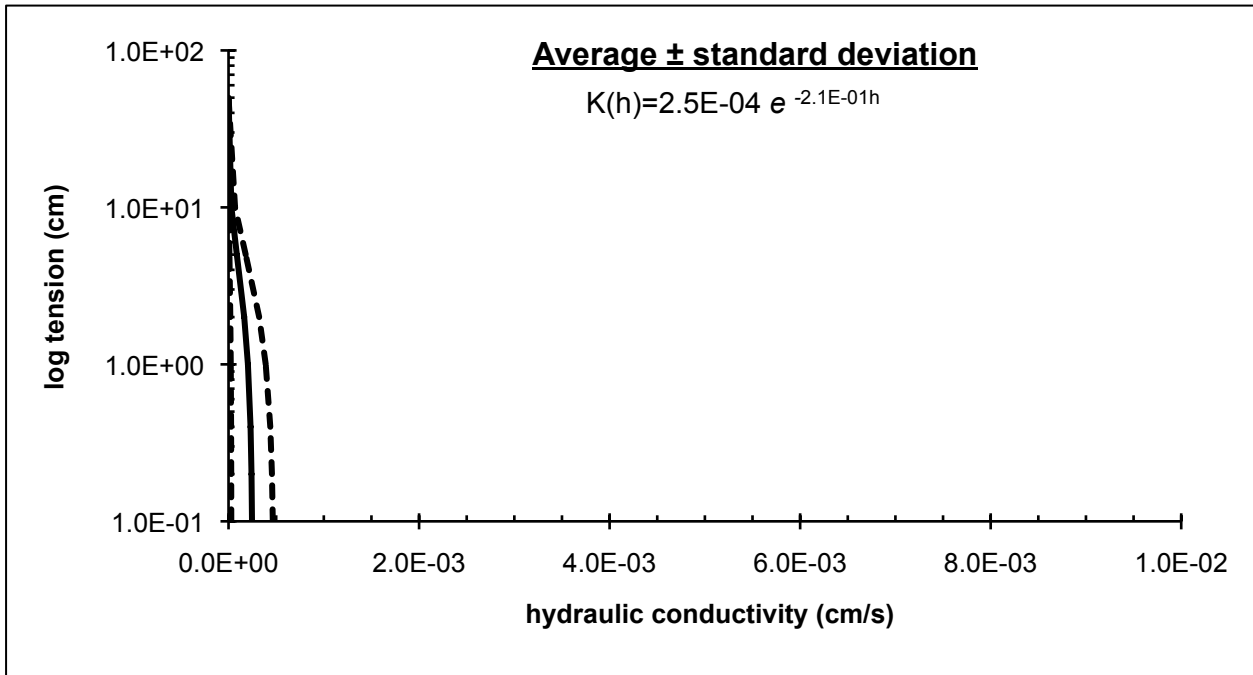

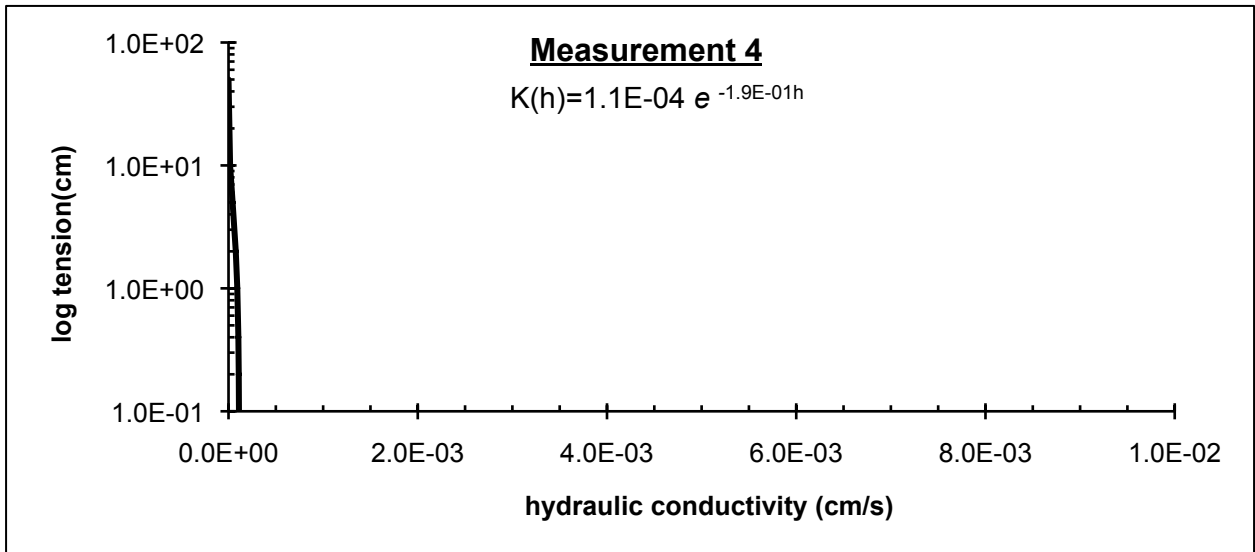
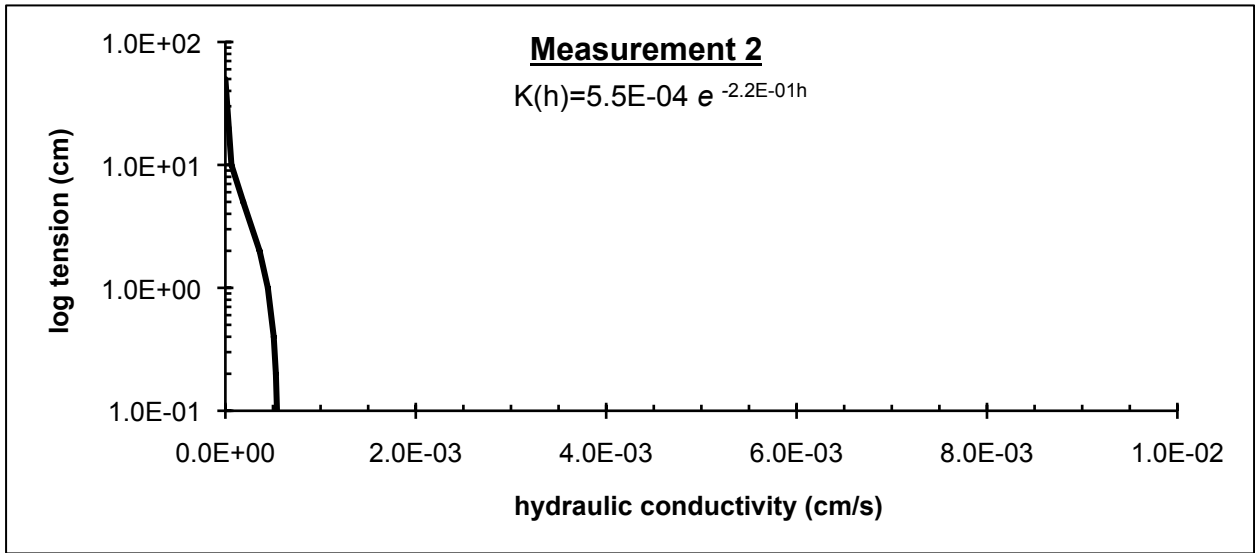

D27. Diamond Ridge Park

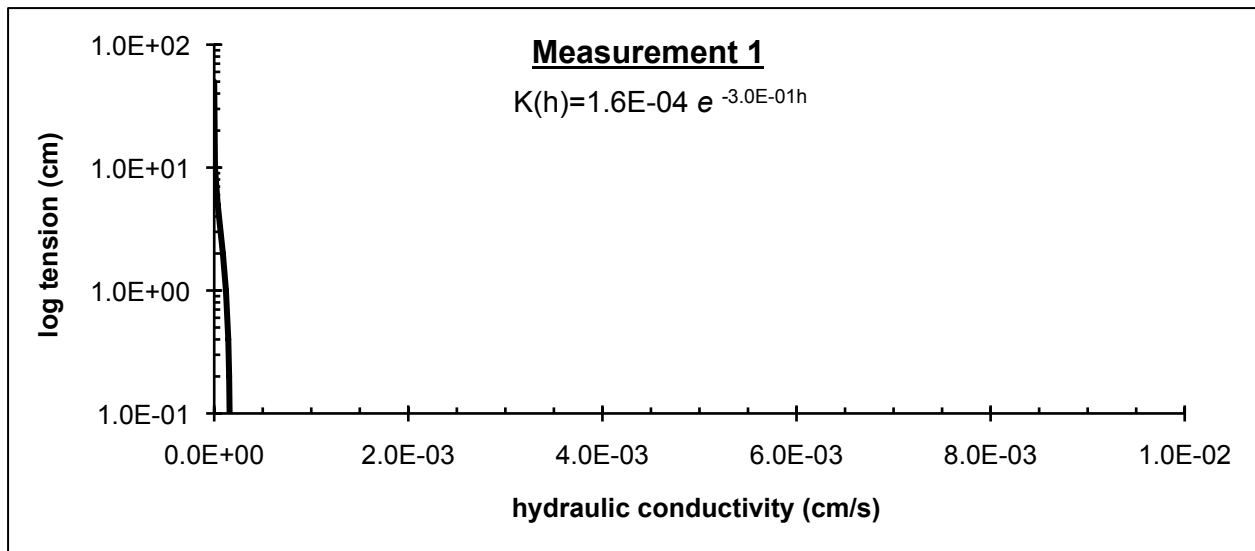
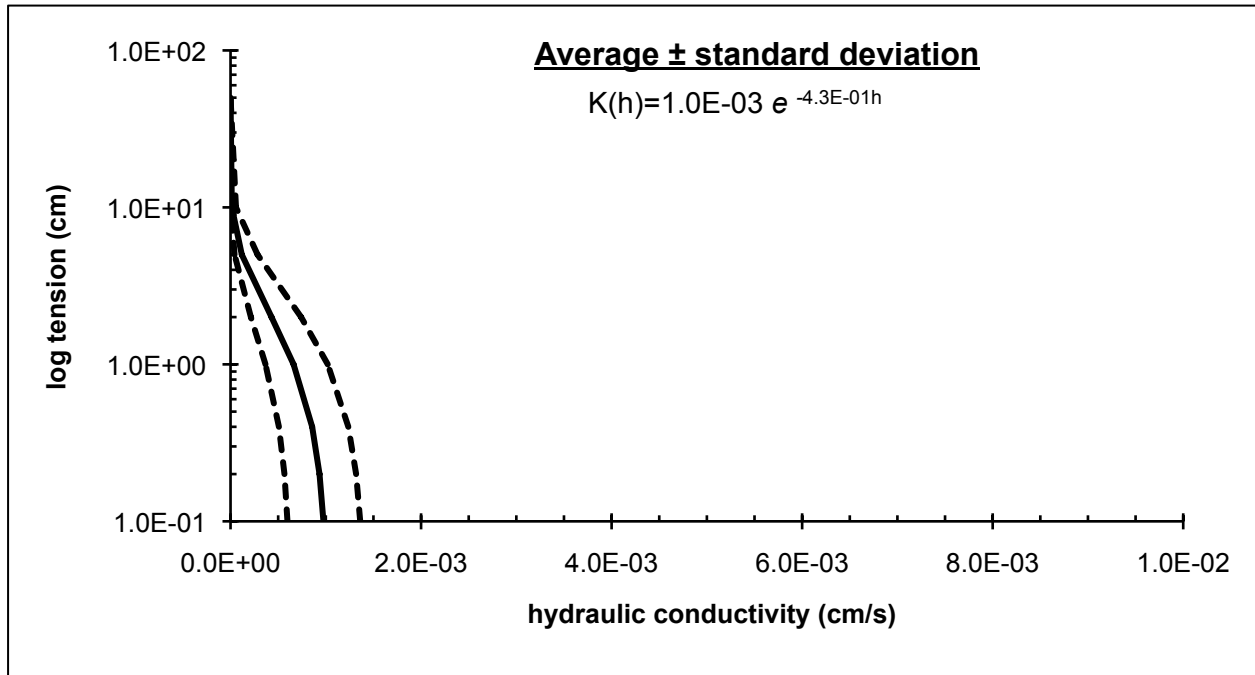

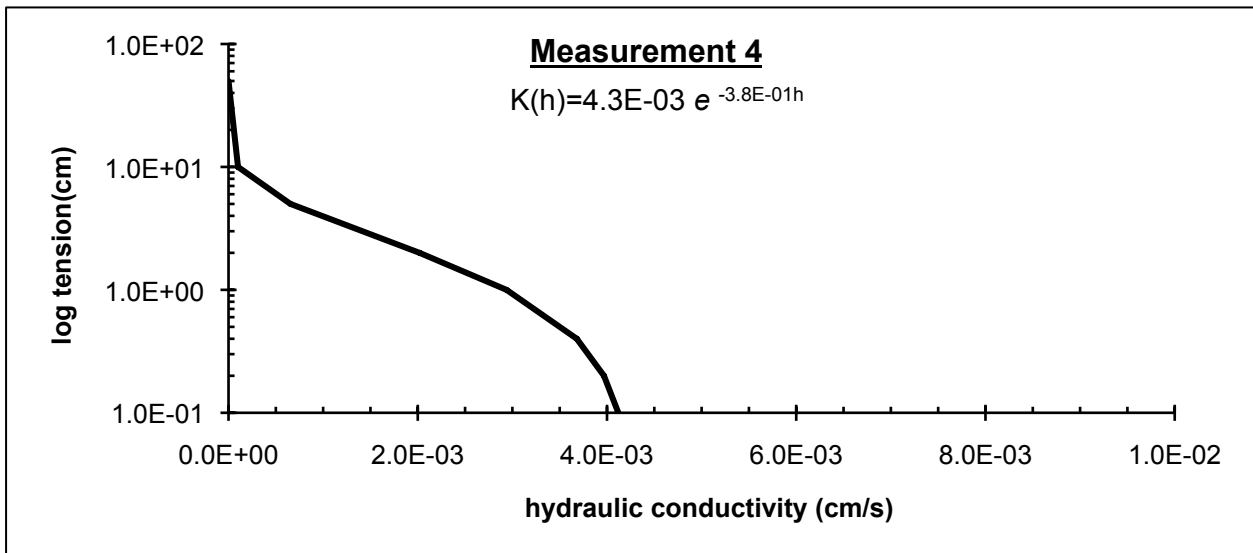
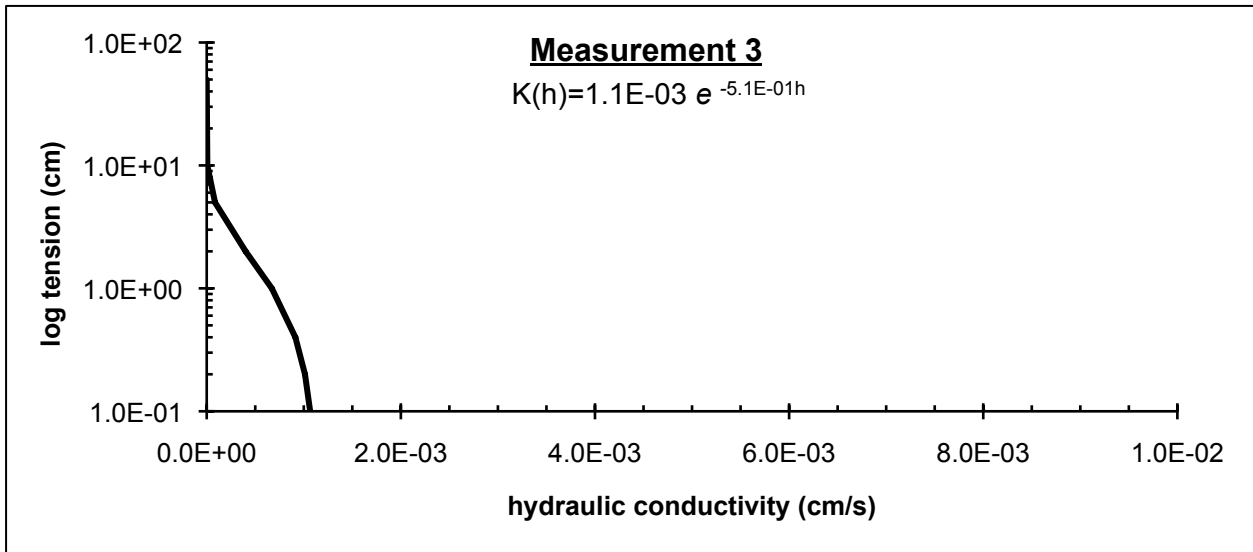
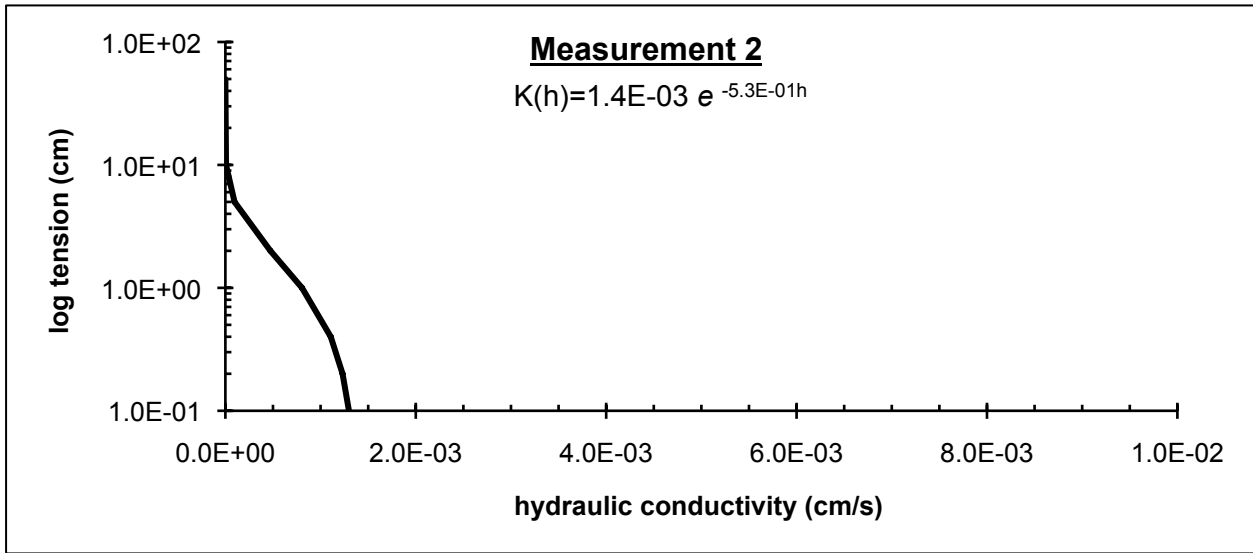

D40. Patapsco State Park at Old Court Rd

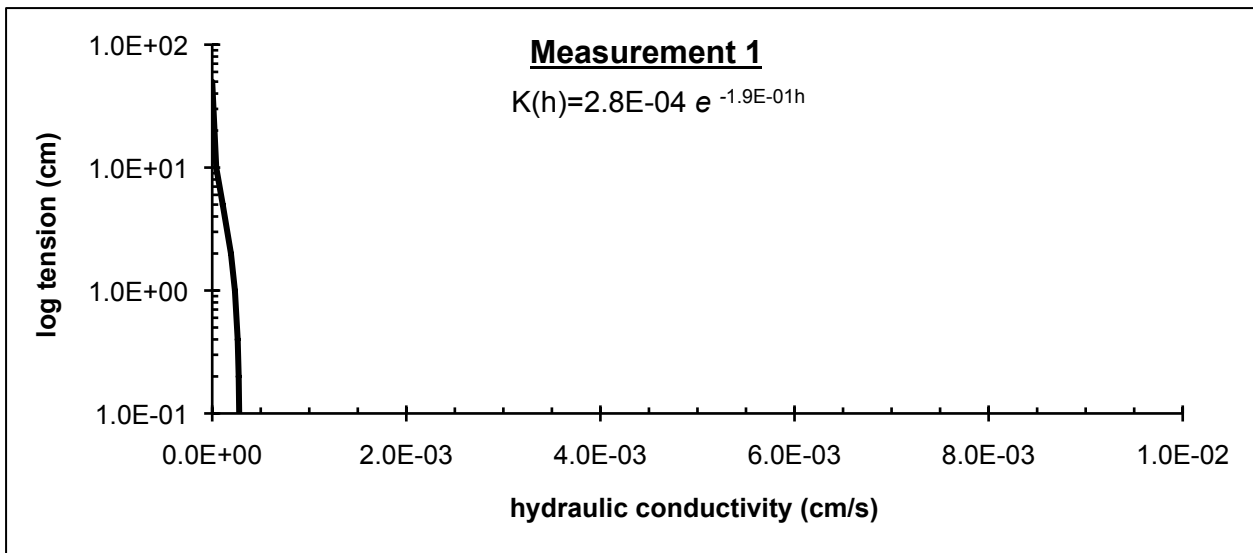
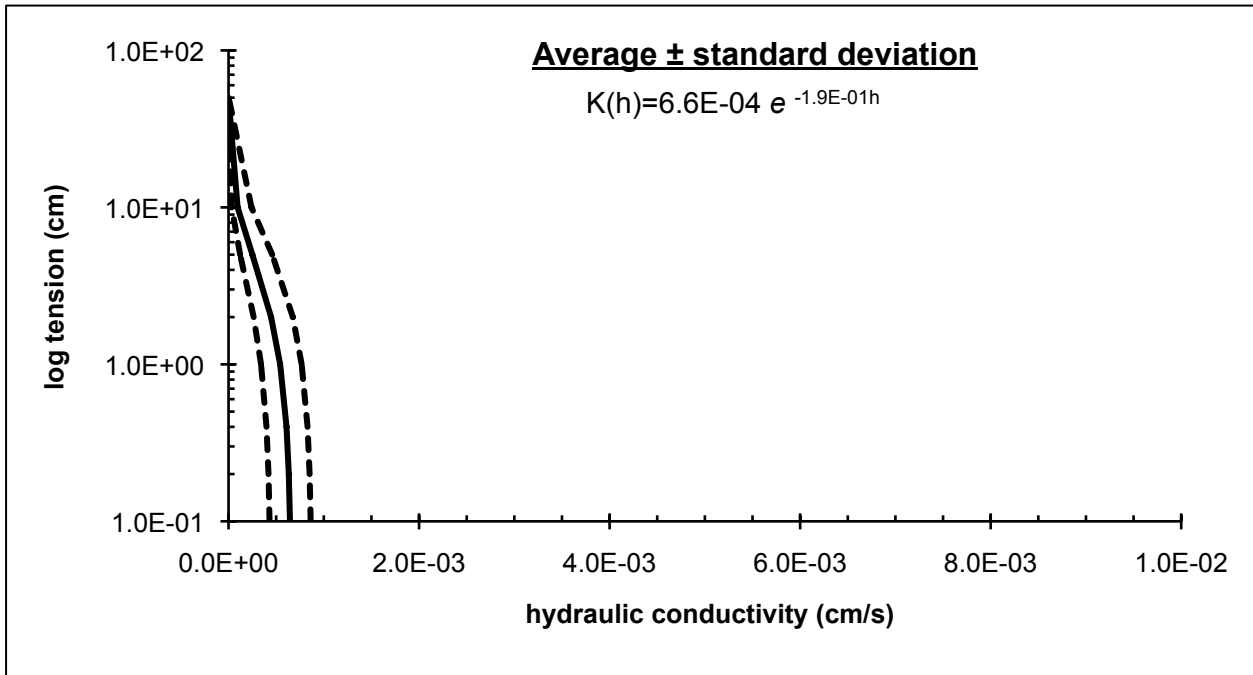

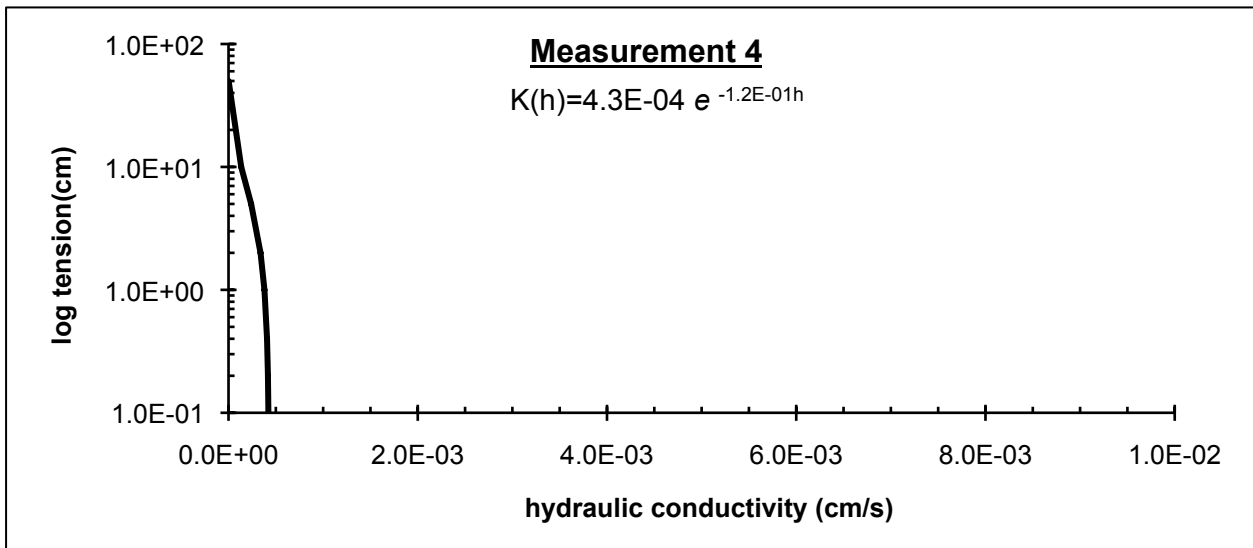
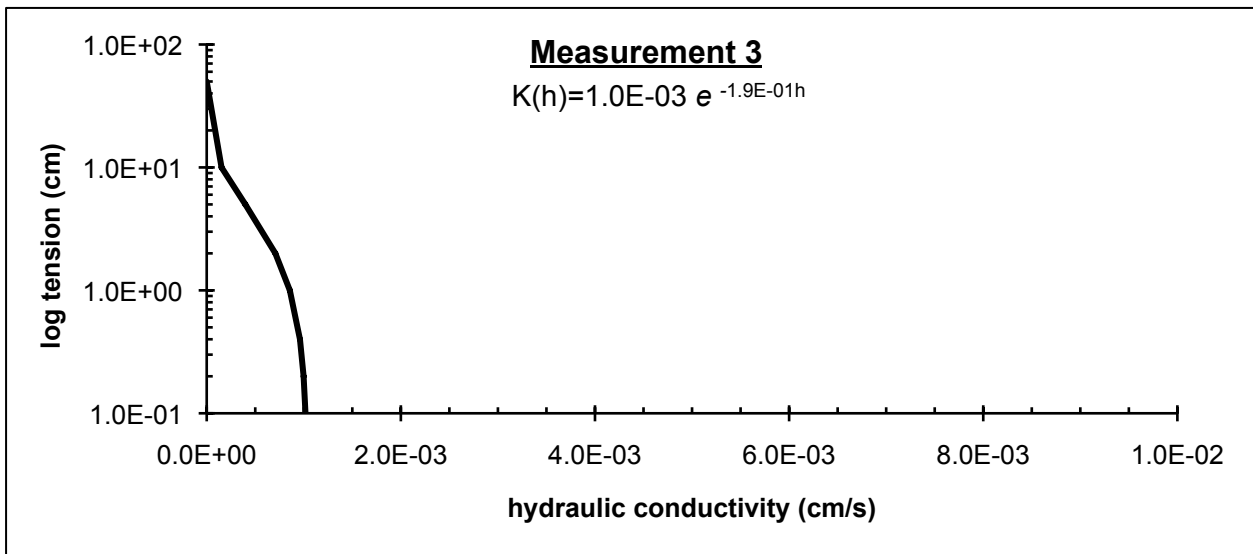
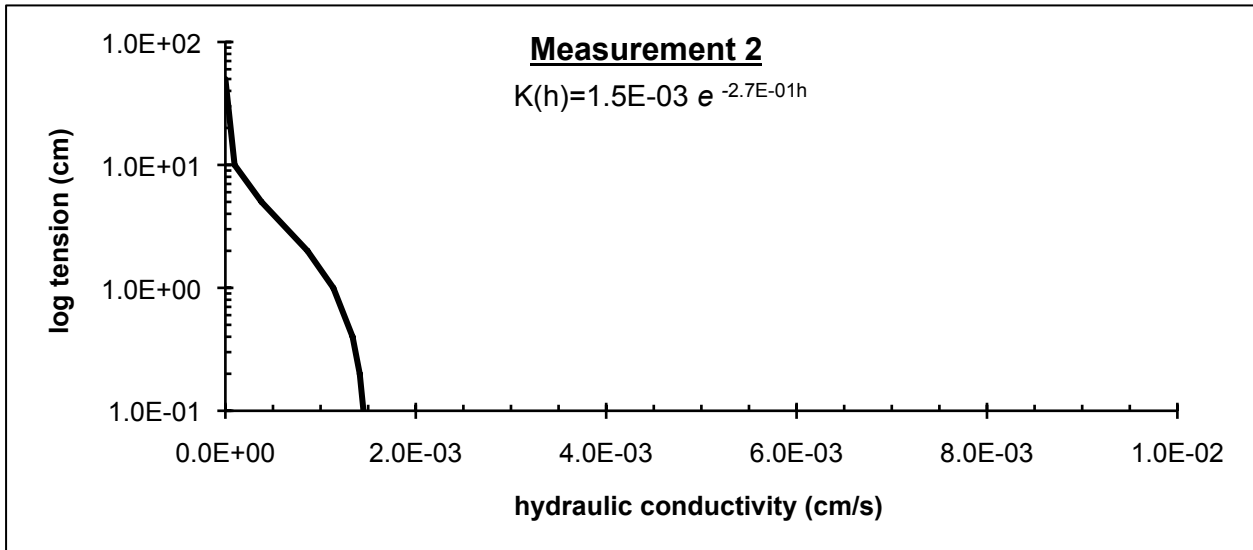

D42. Granite Rd at Harvest Fields Rd

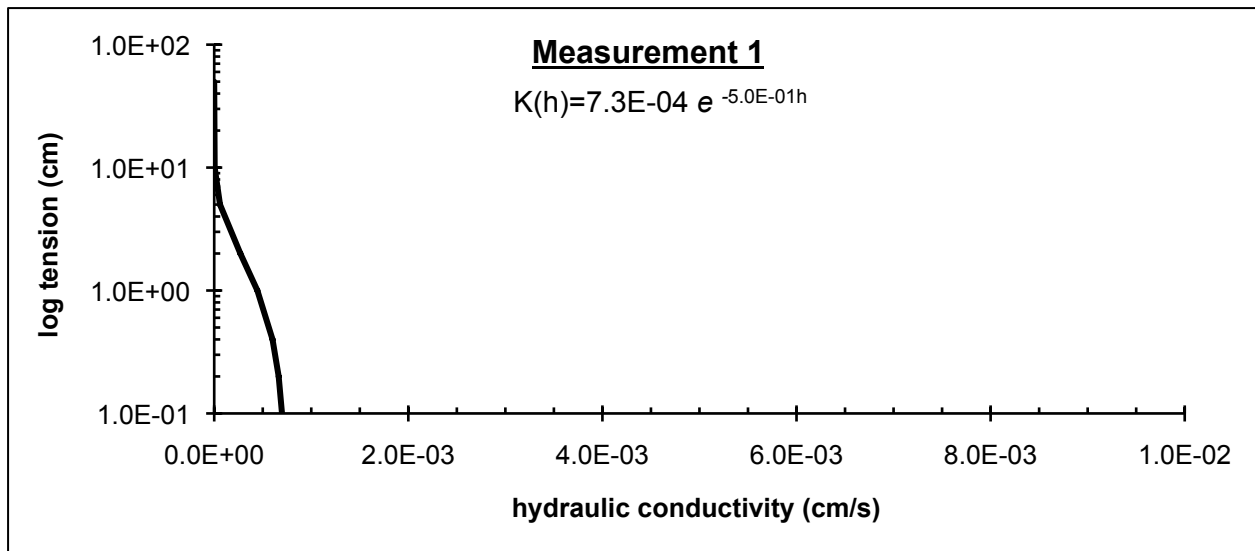
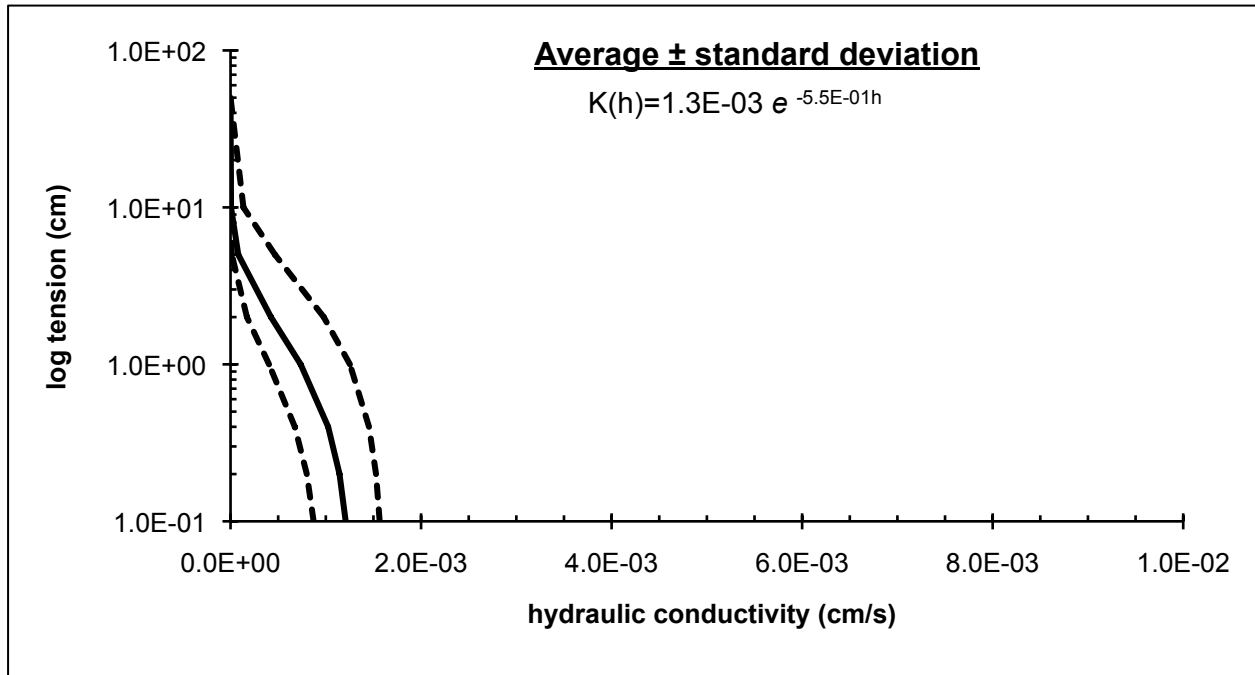

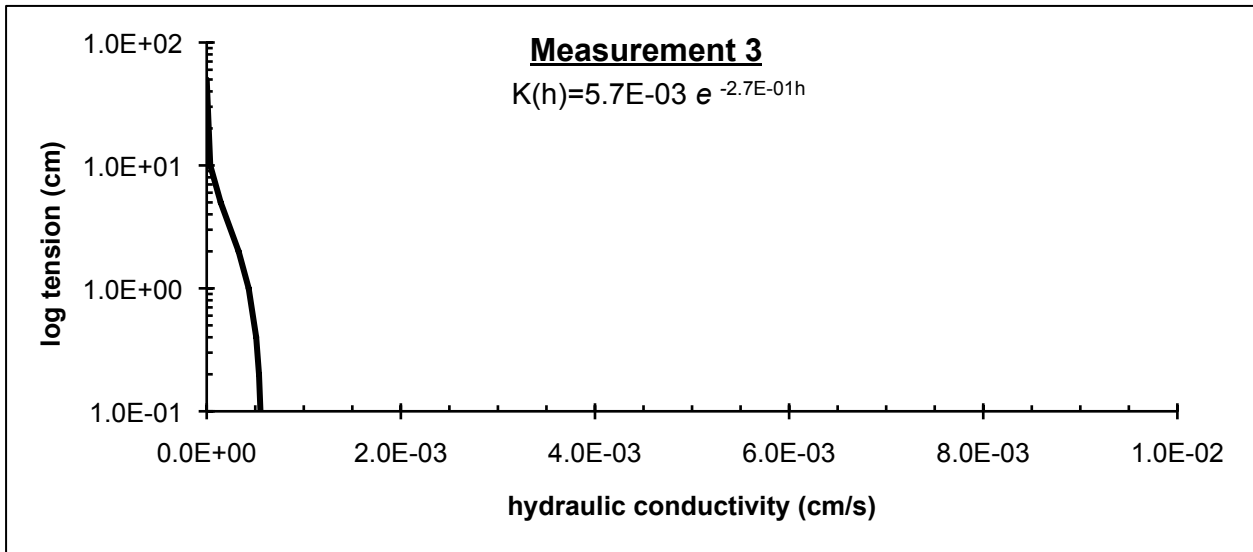
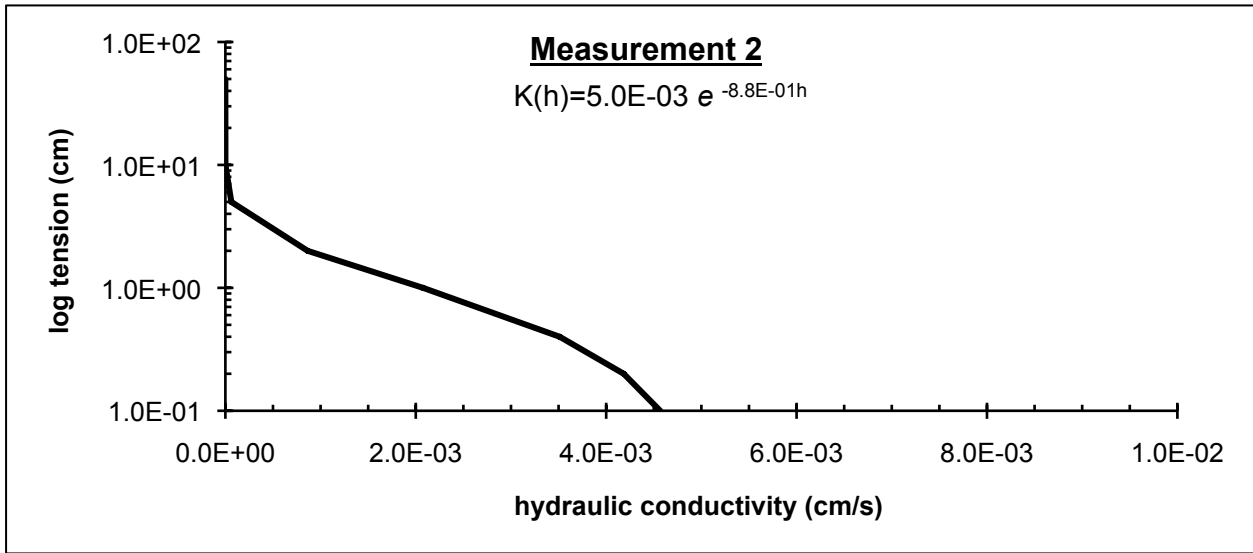

D56. Liberty Rd at Lyons Mill Rd

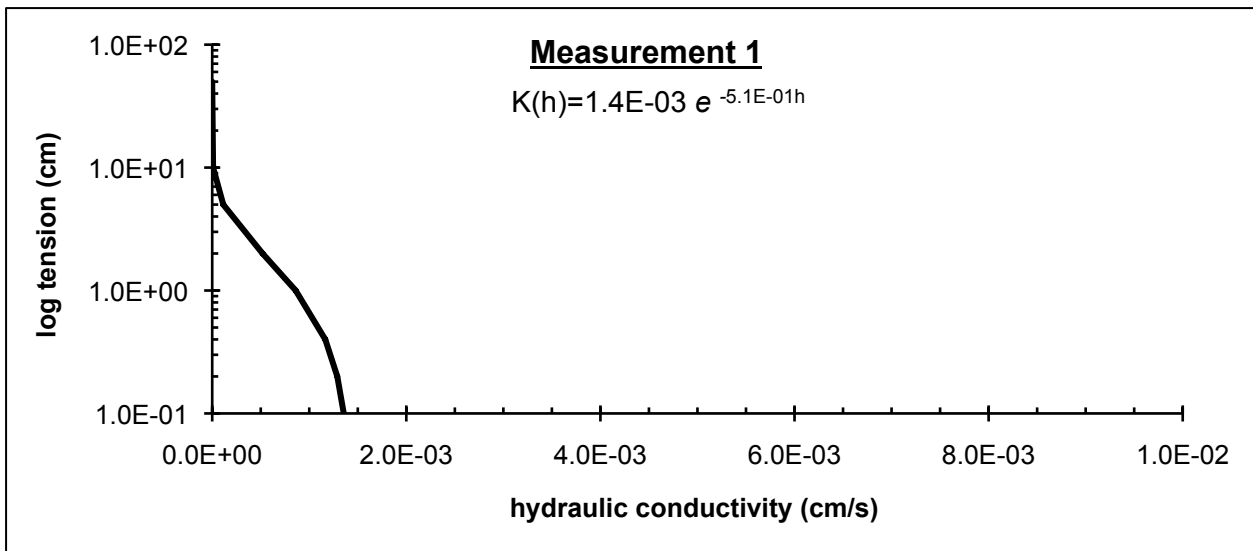
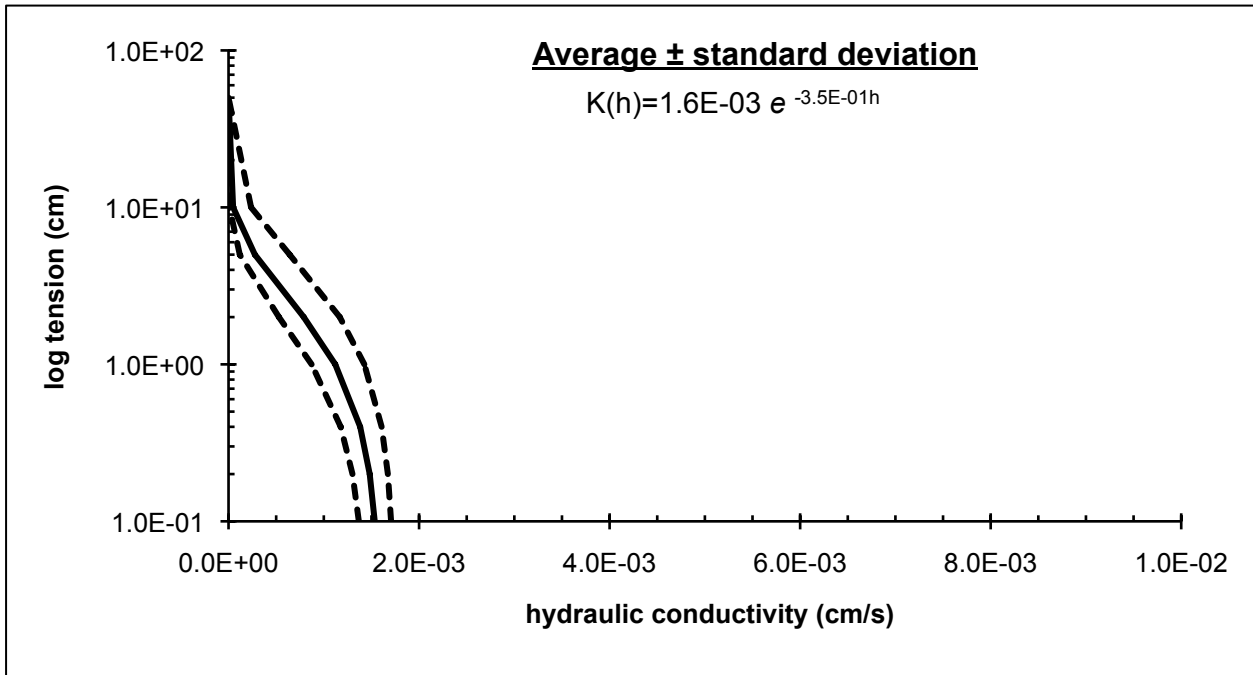

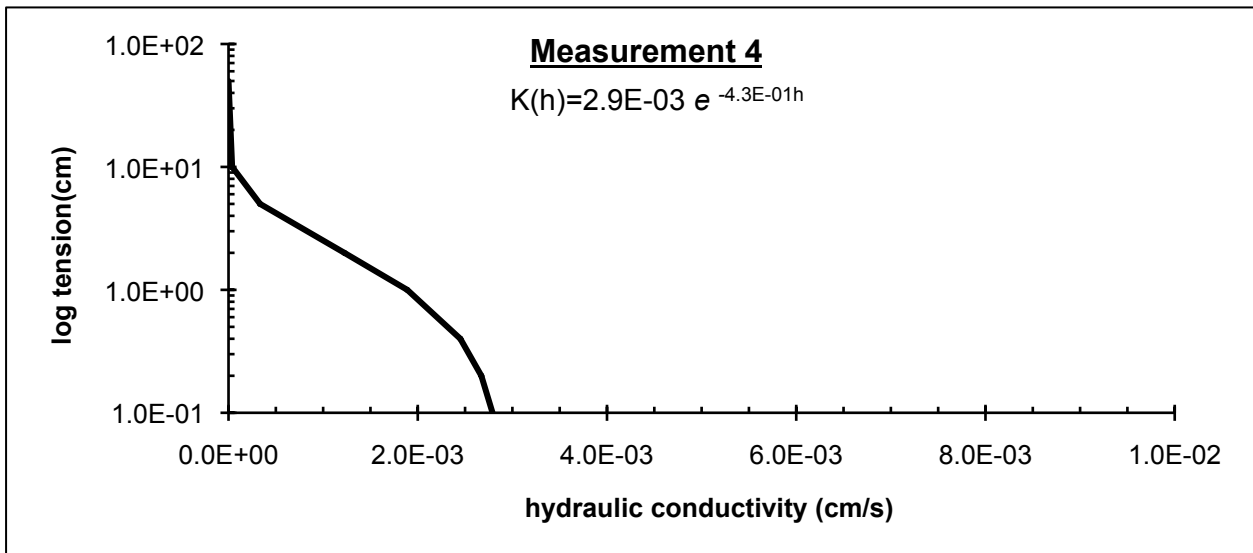
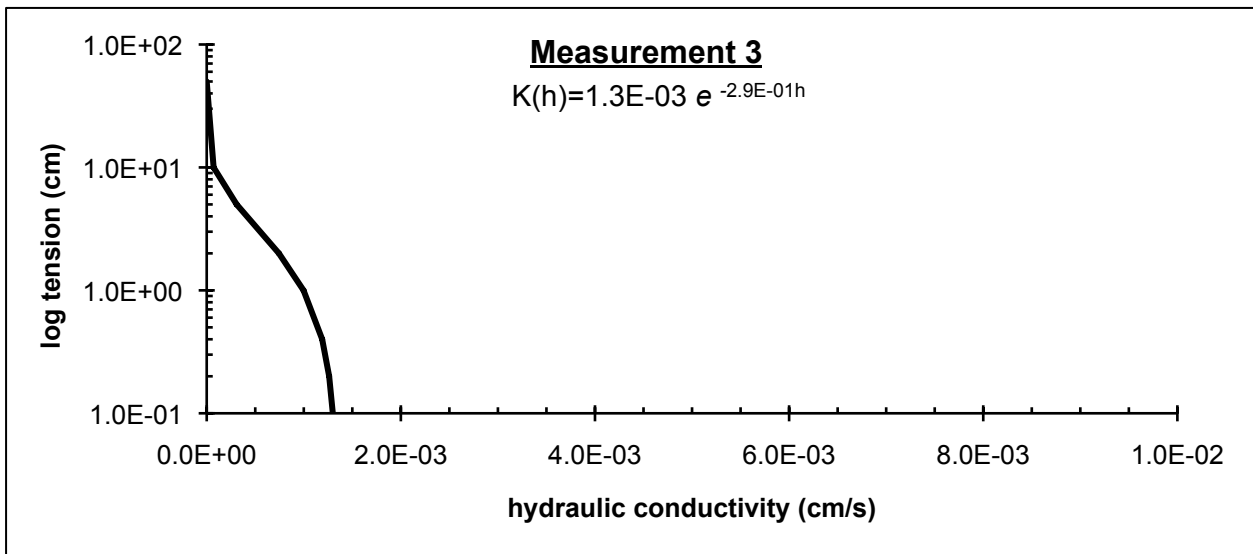
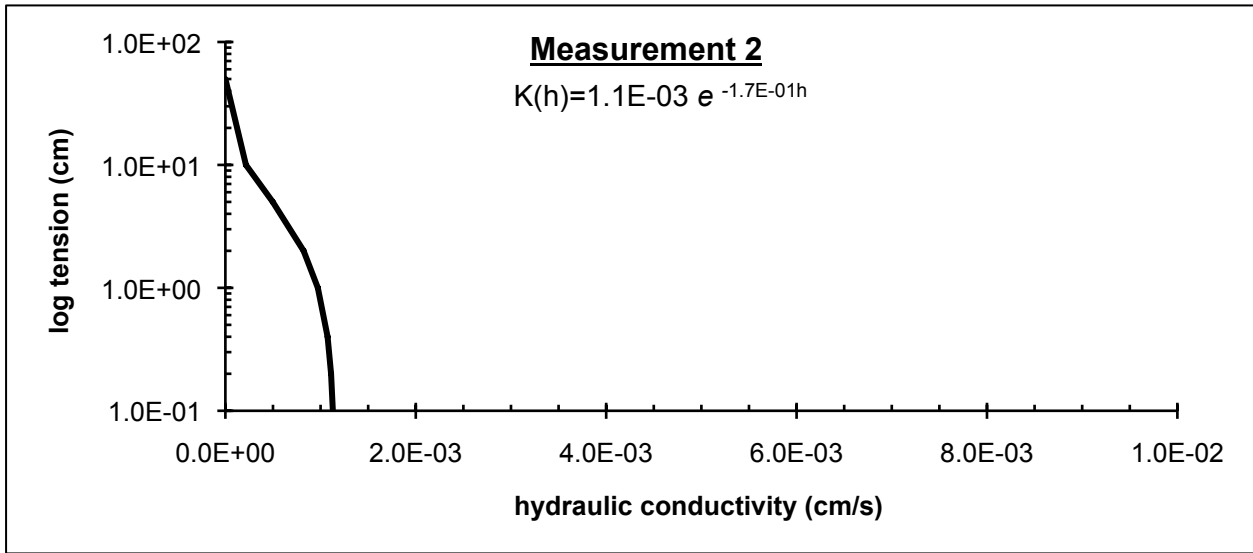

D61. Mays Chapel Park

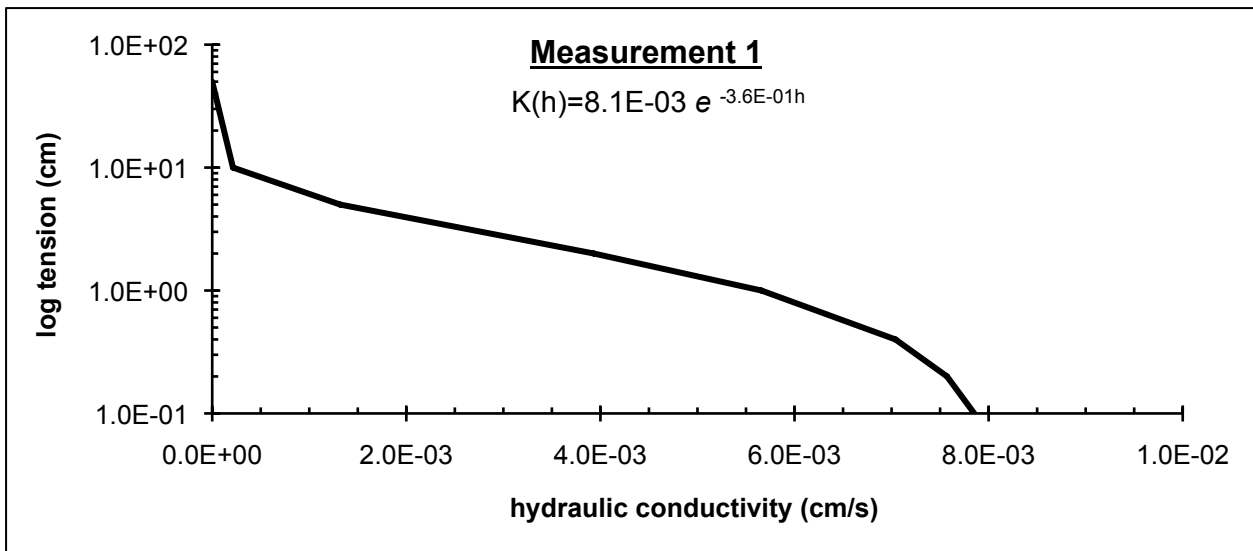
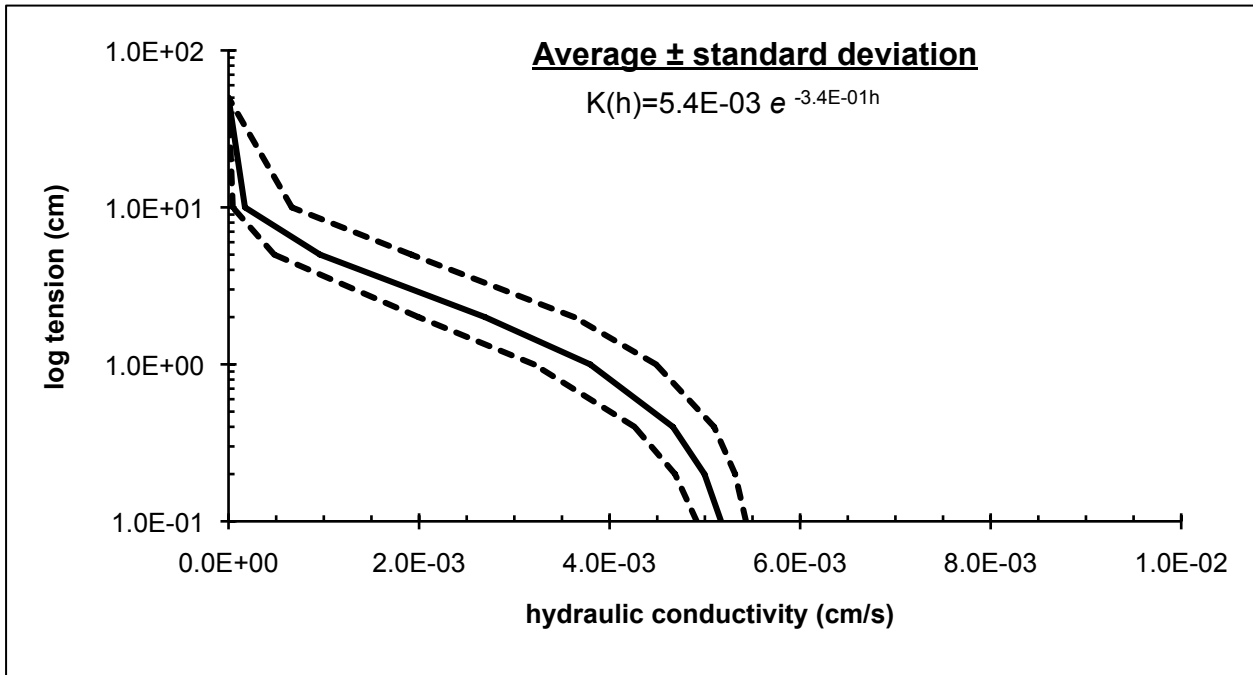

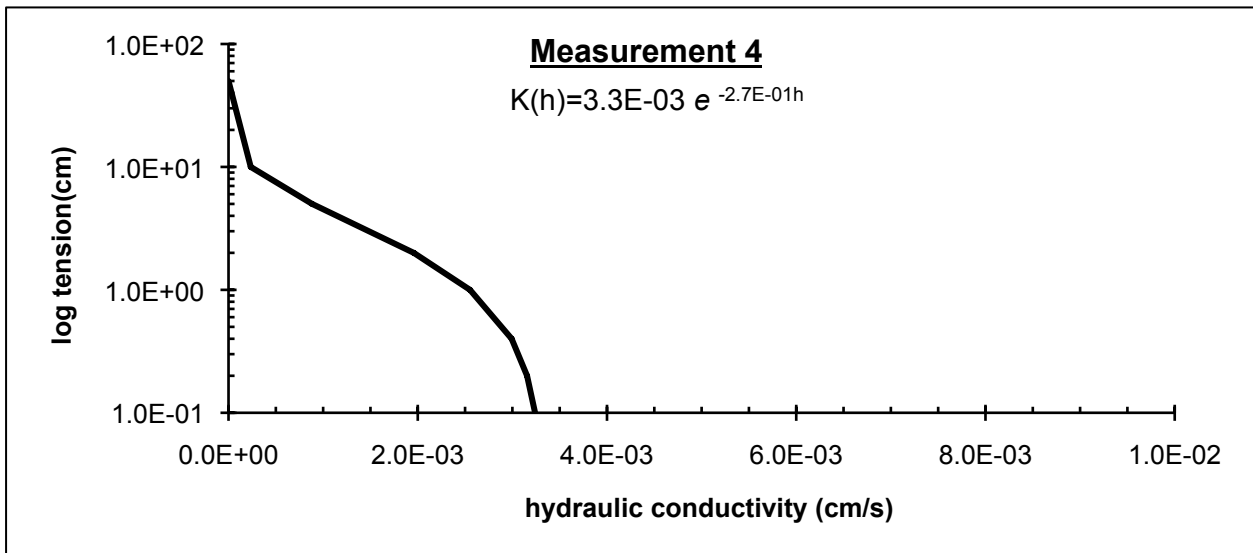
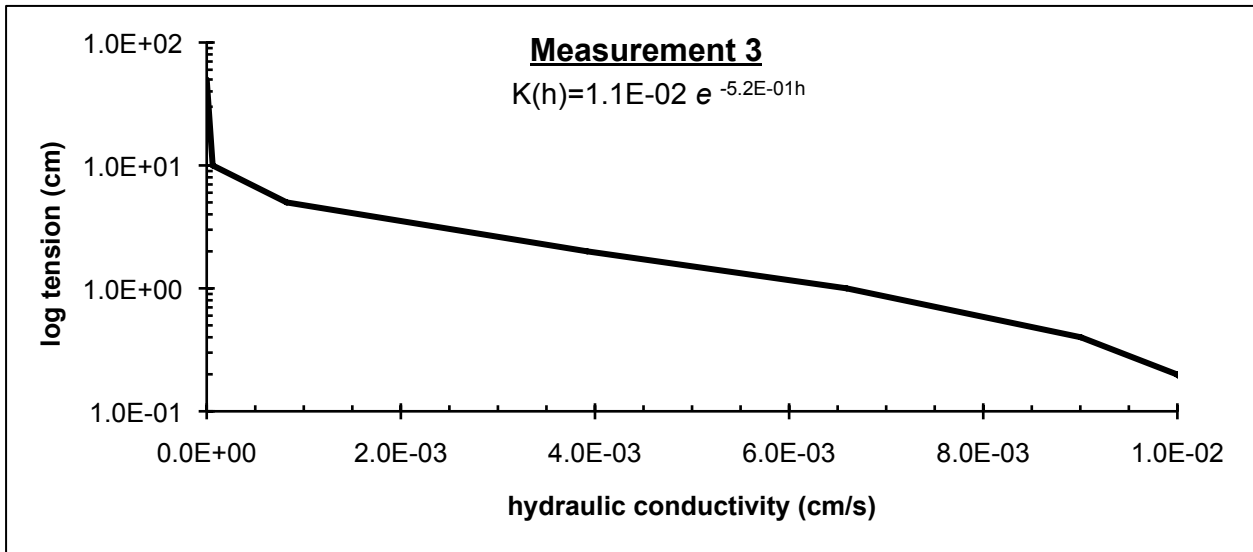
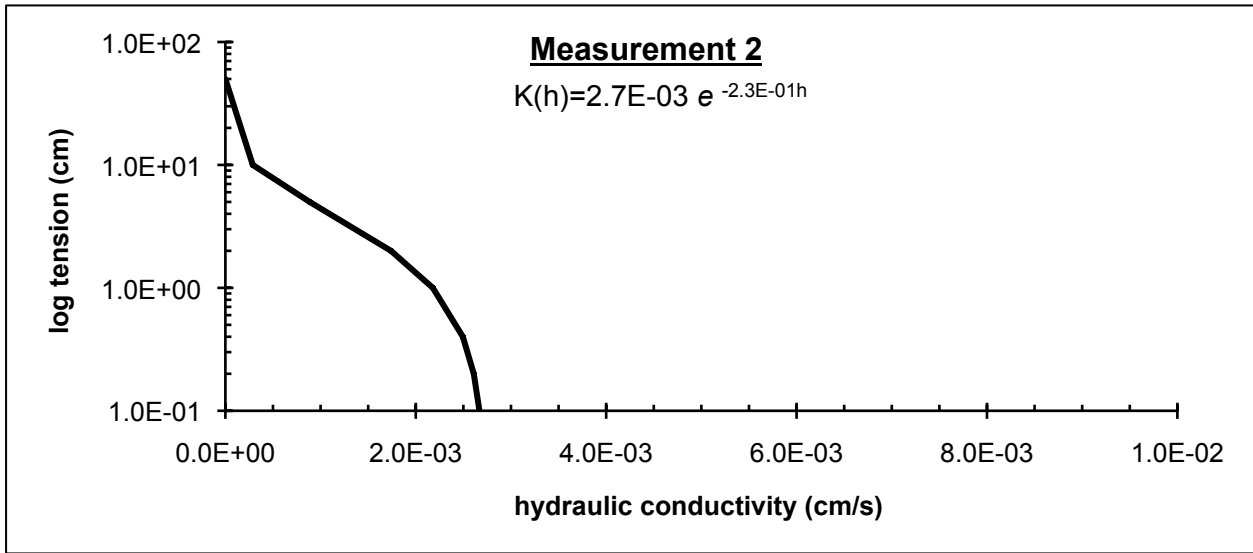

D75. SWR at Waterspout Ct

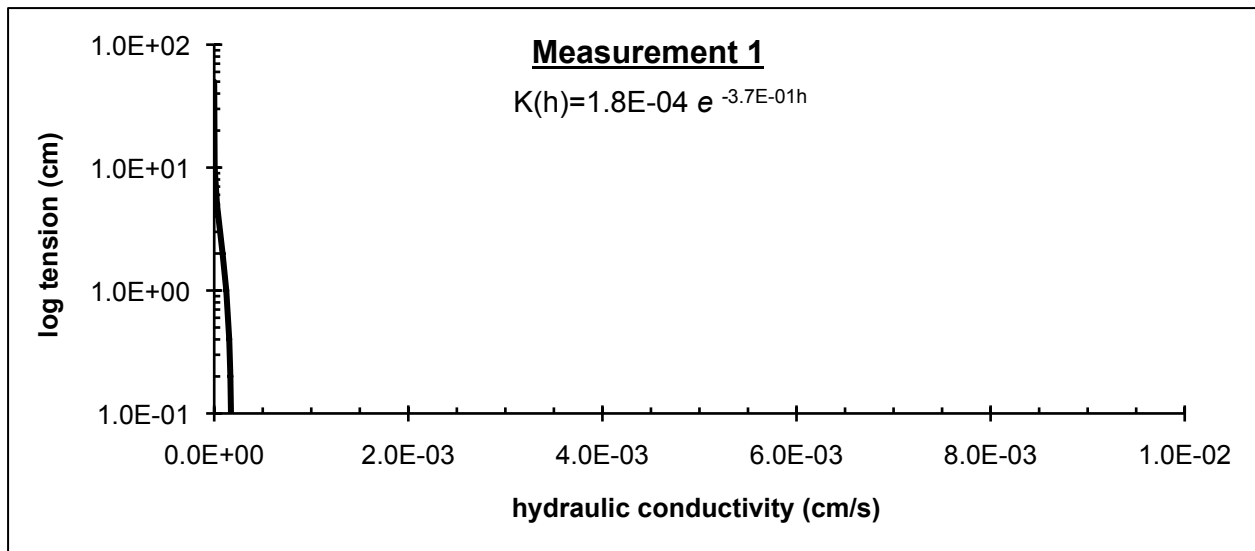
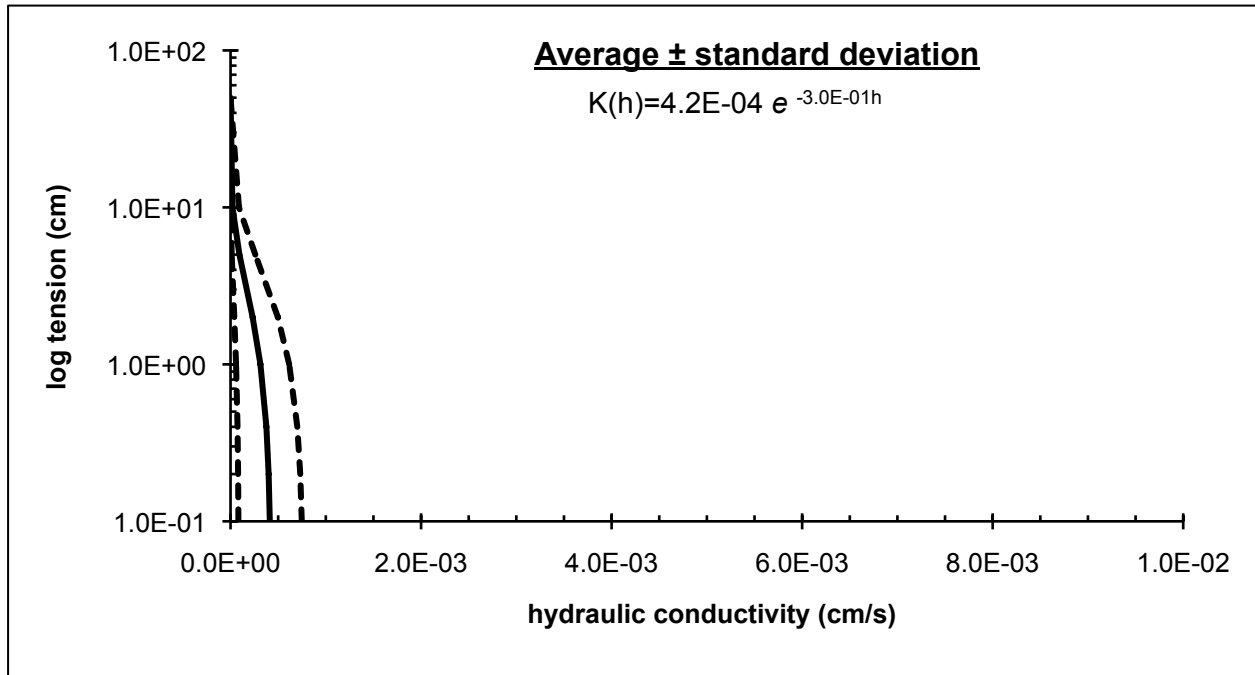

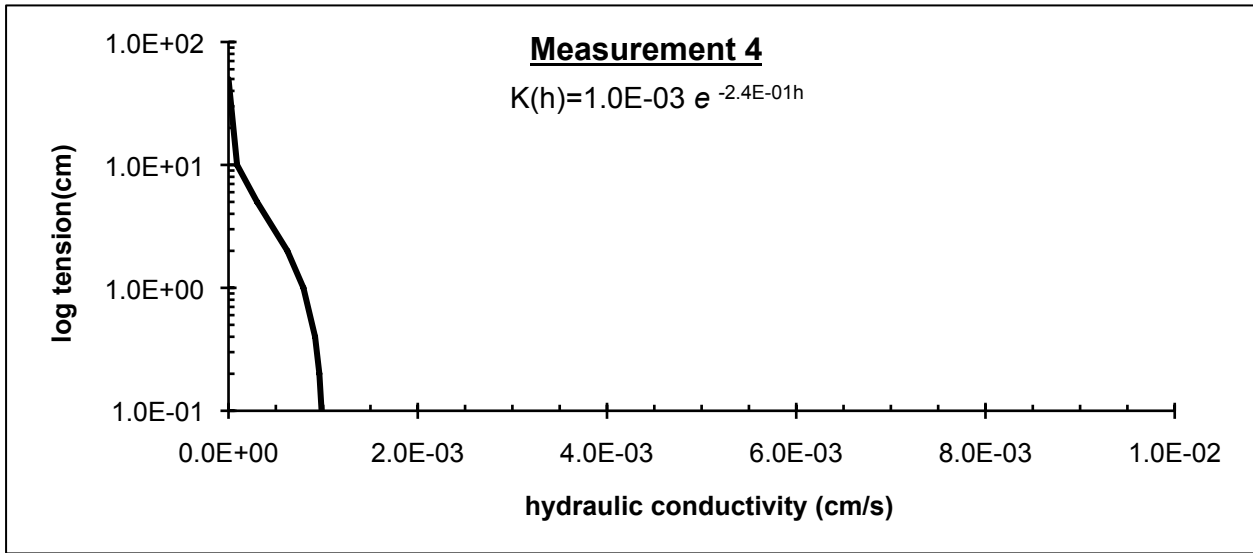

D77. Oregon Ridge Park

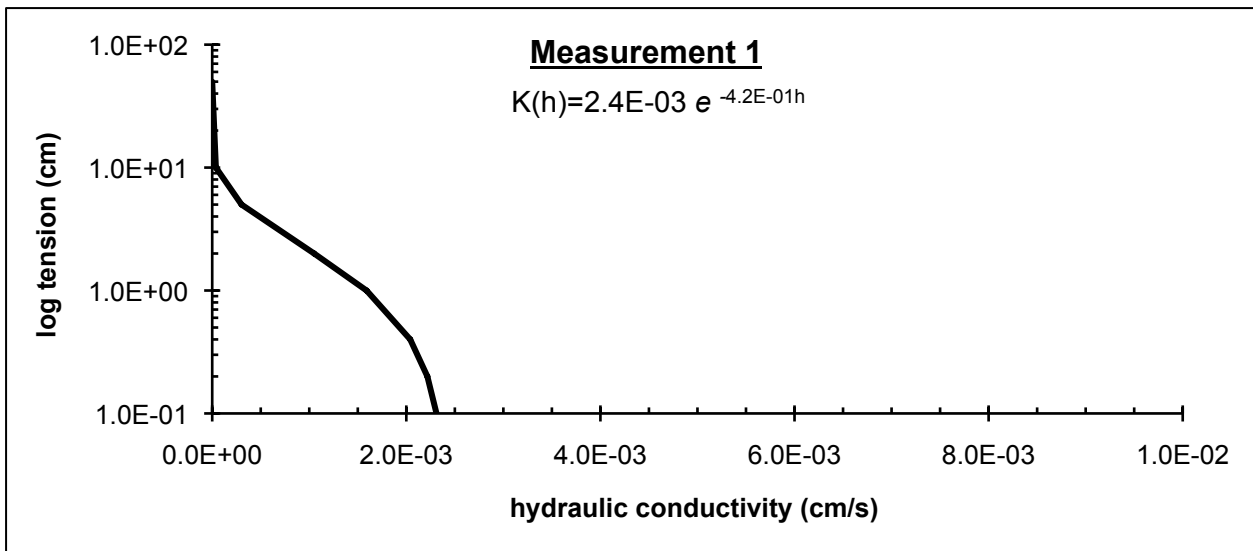
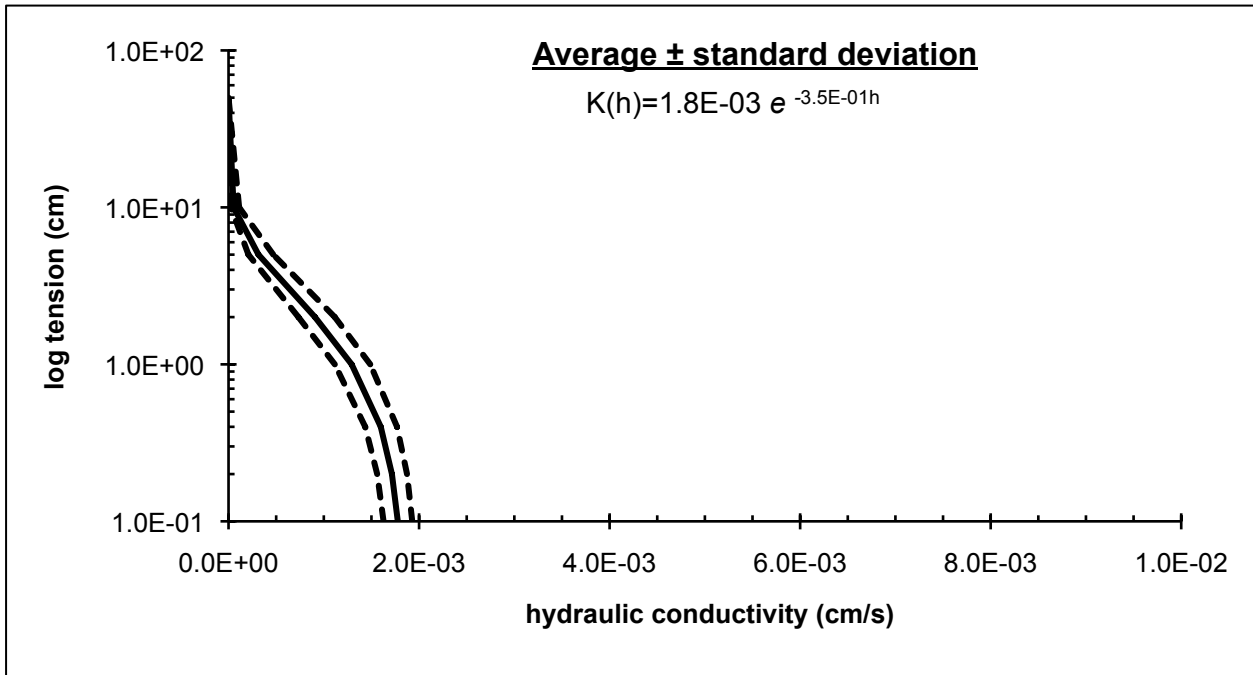

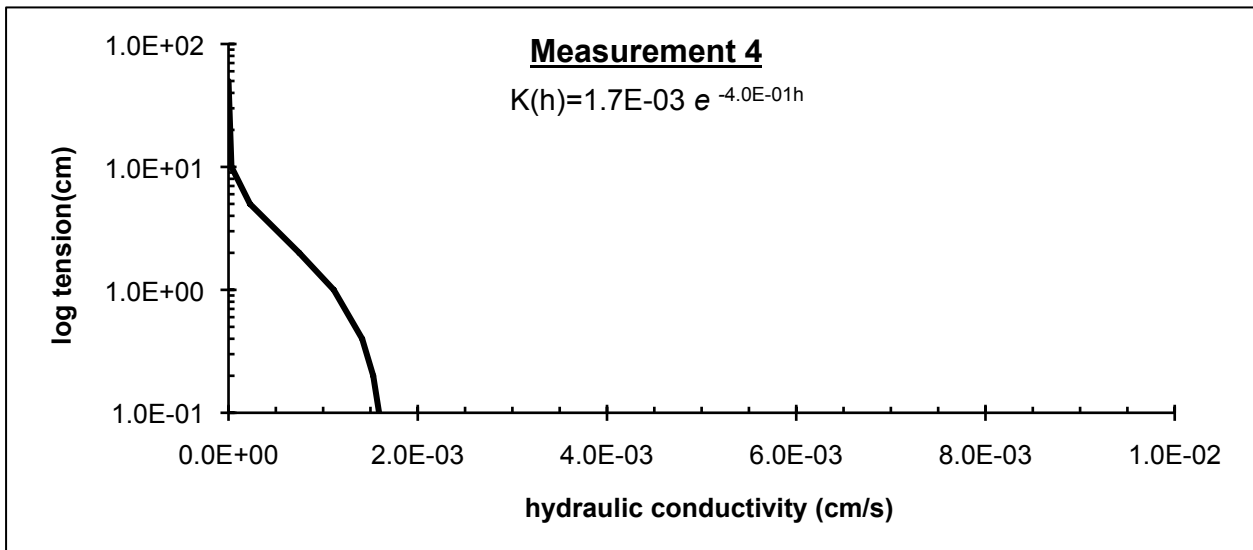
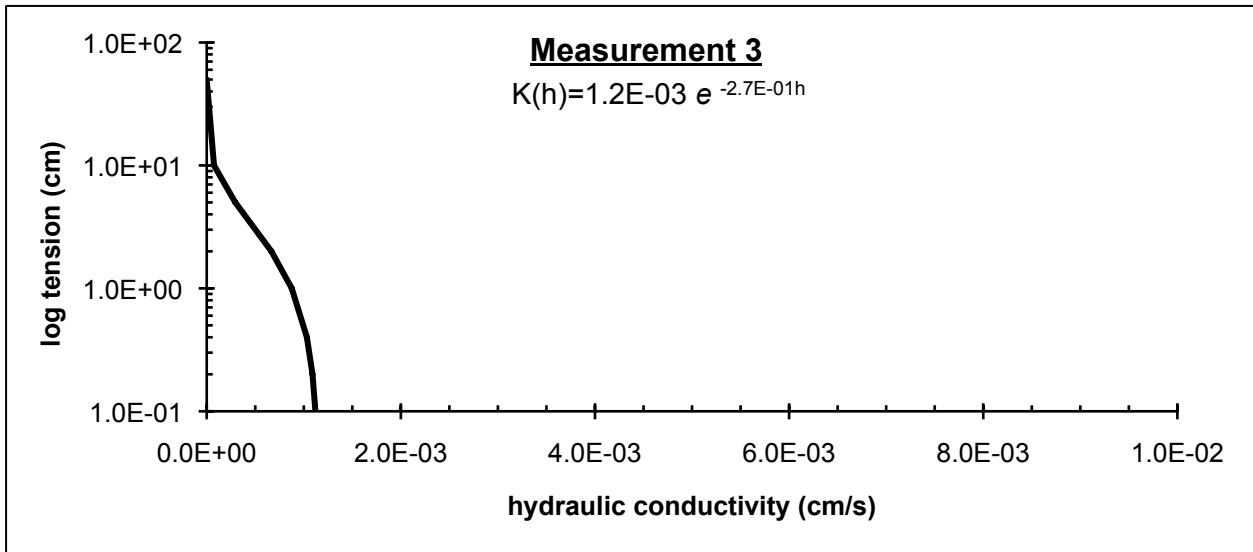
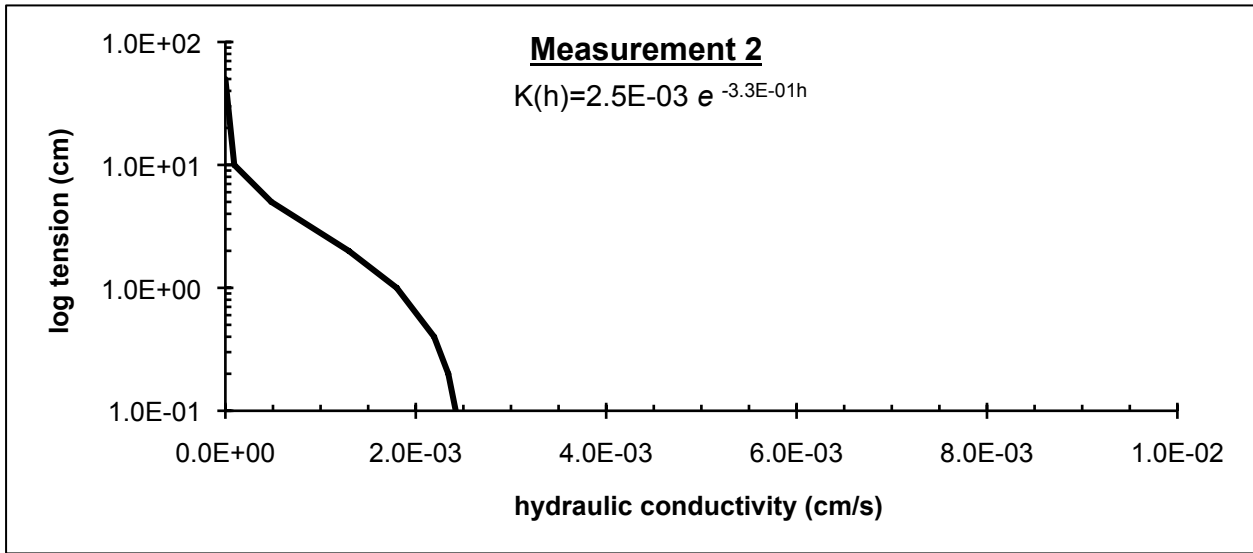

D90. Reisterstown Regional Park

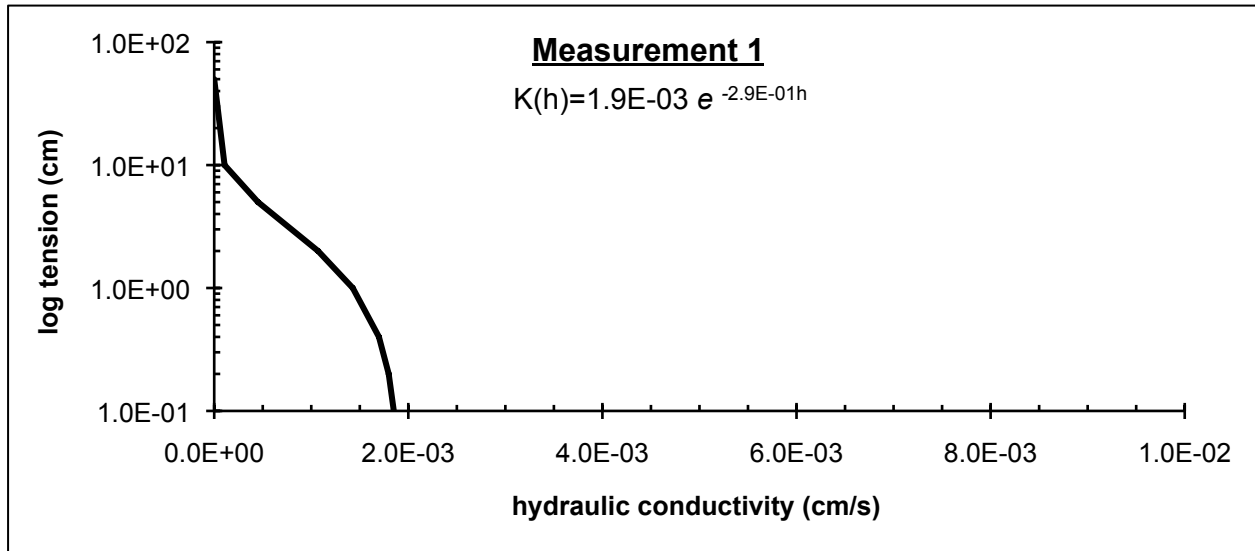

W1. Morrell Park

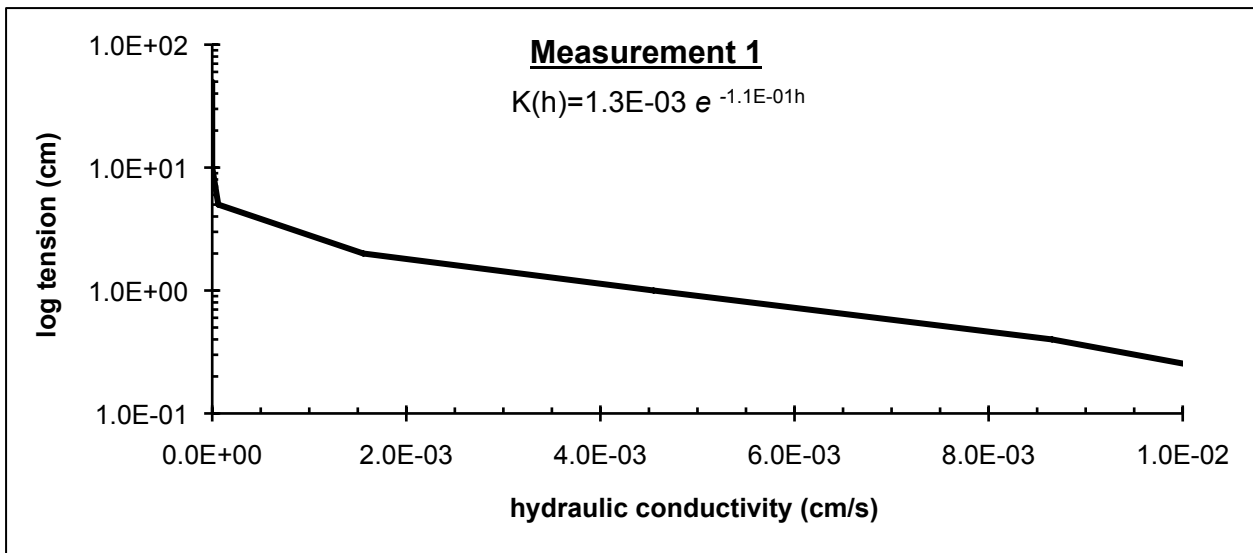
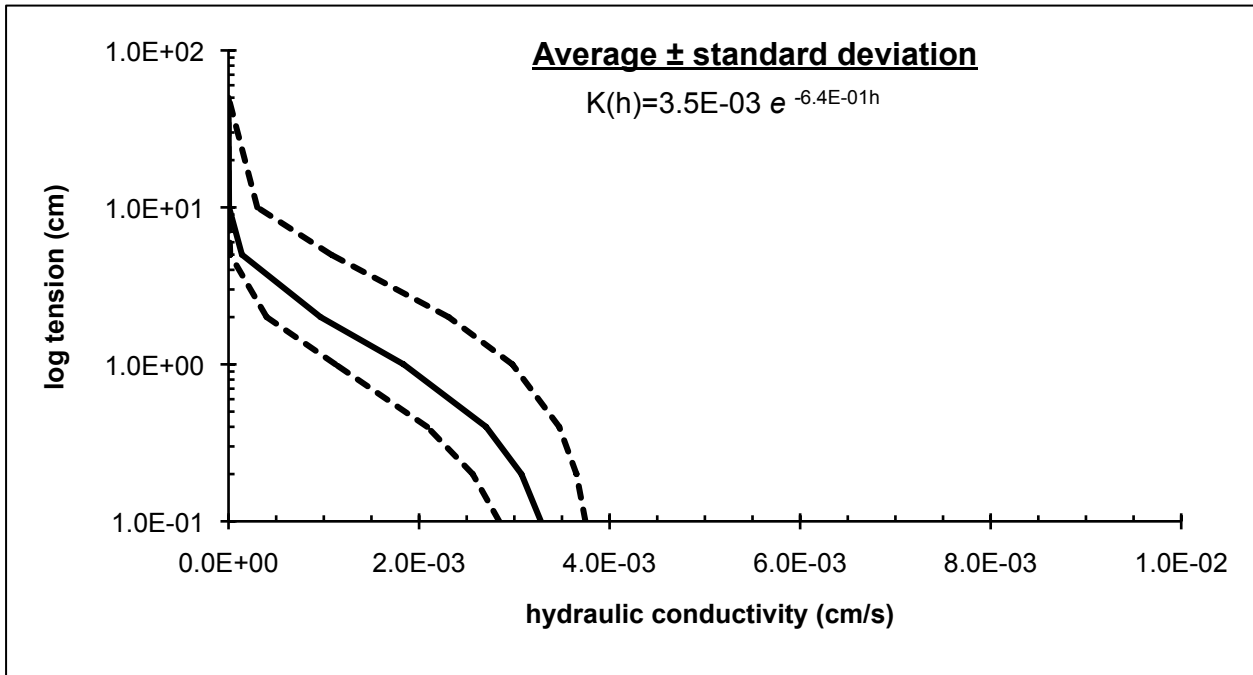

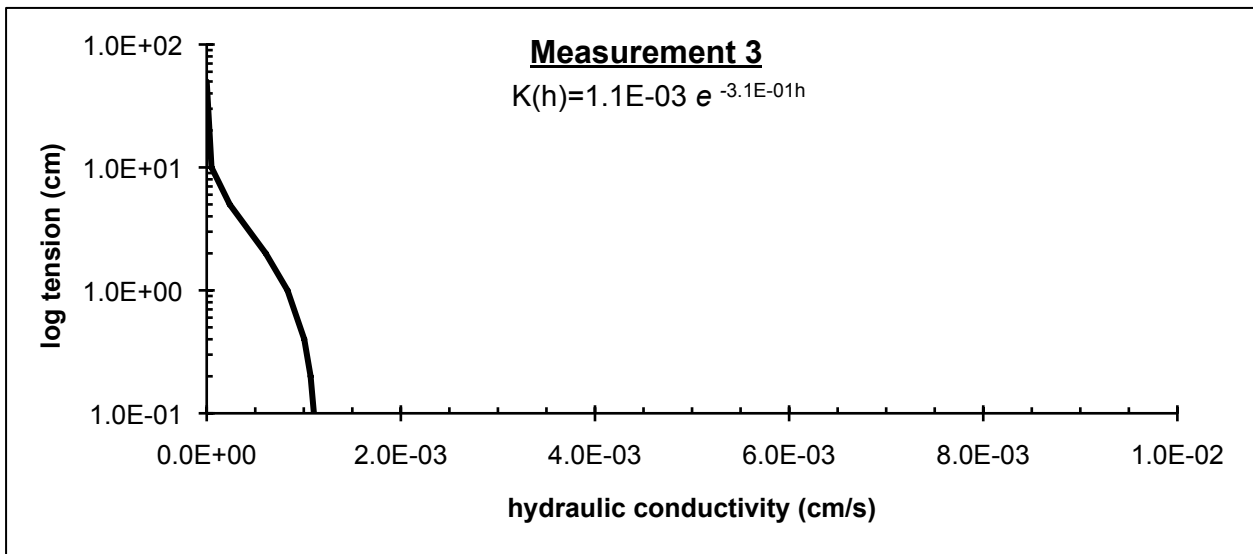
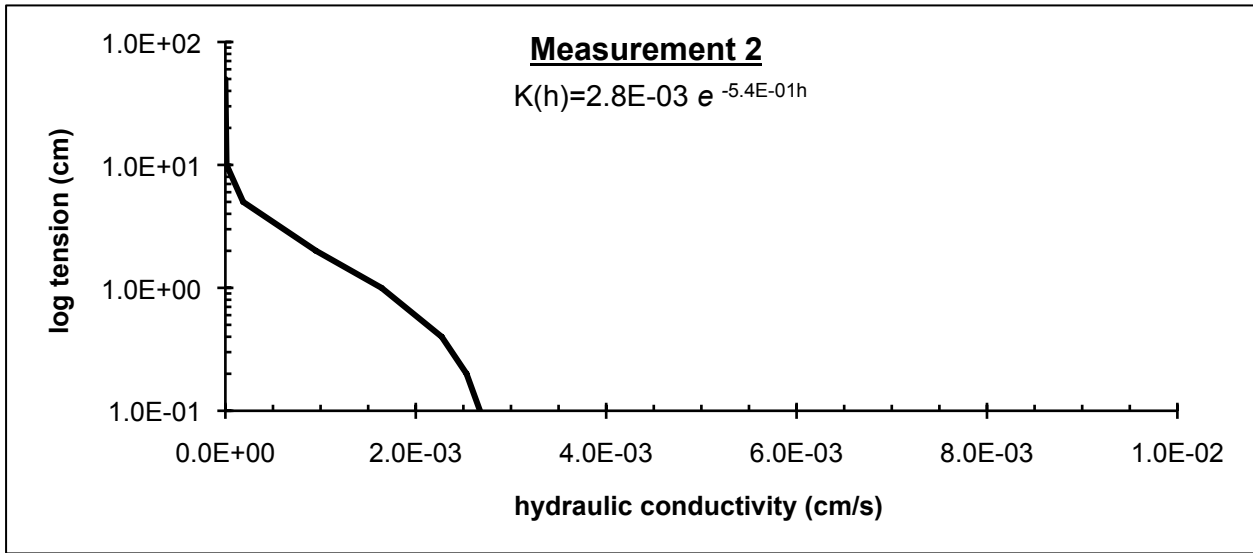

W2. Carroll Park

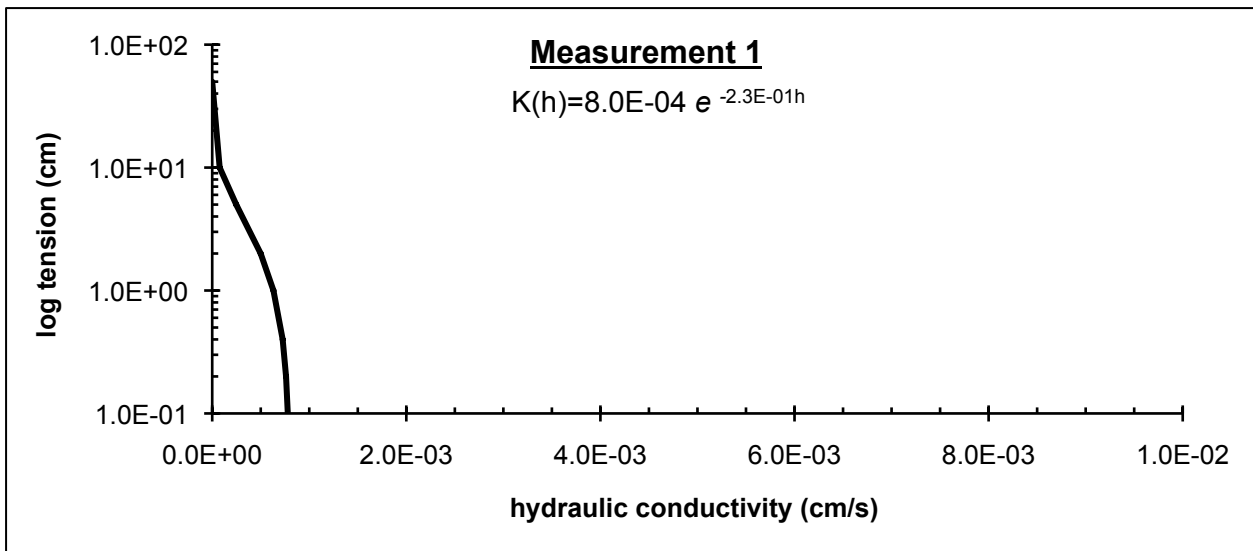
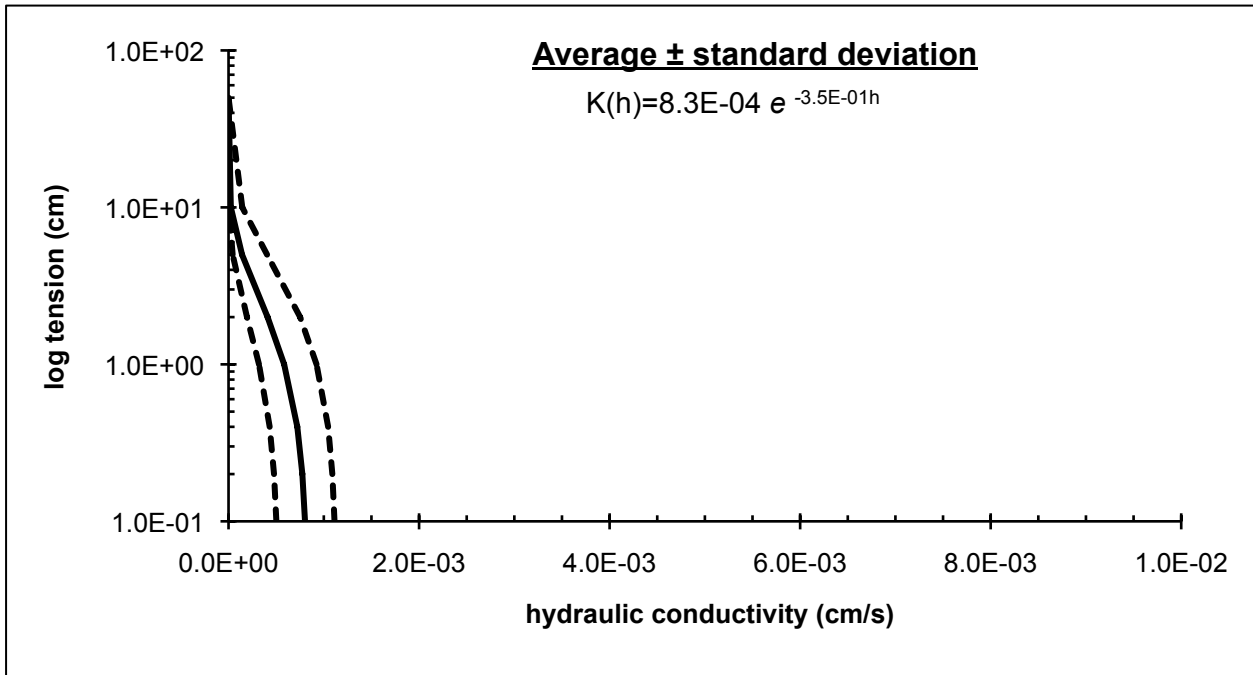

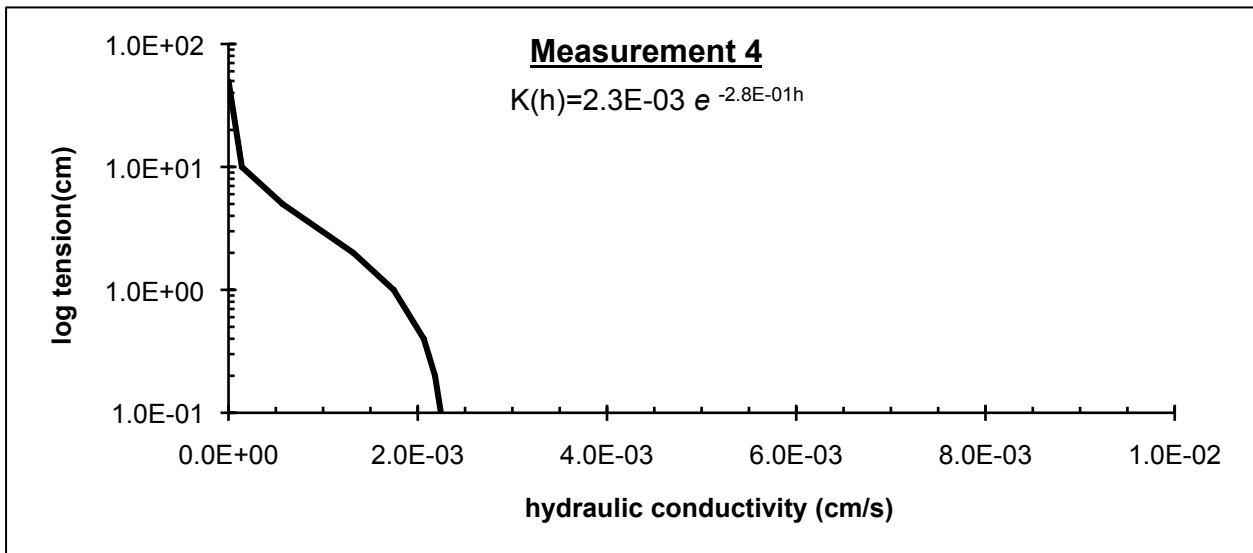
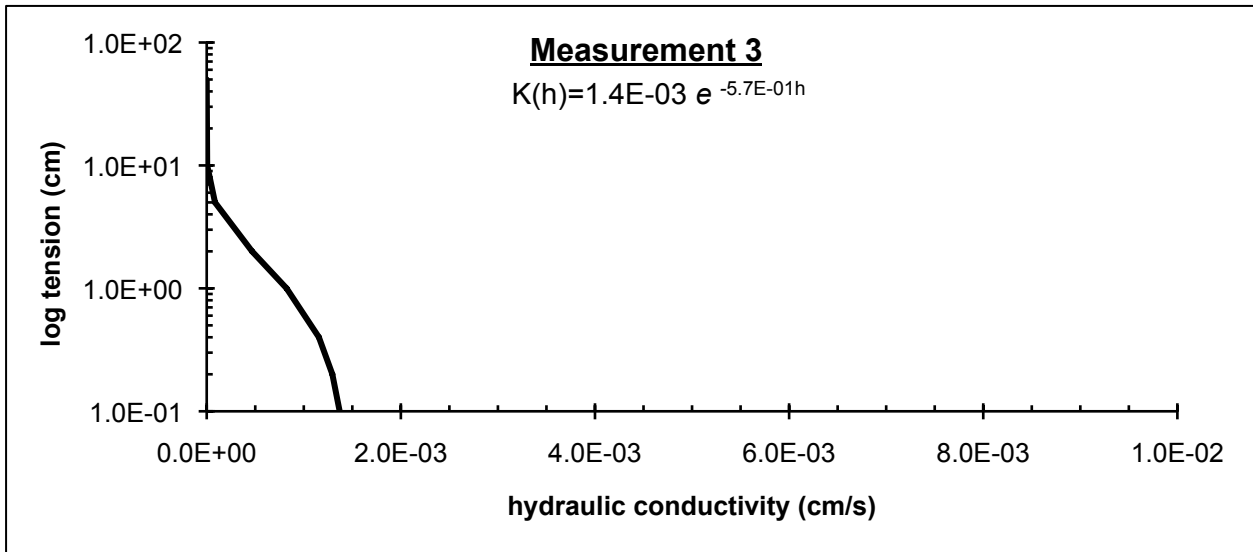
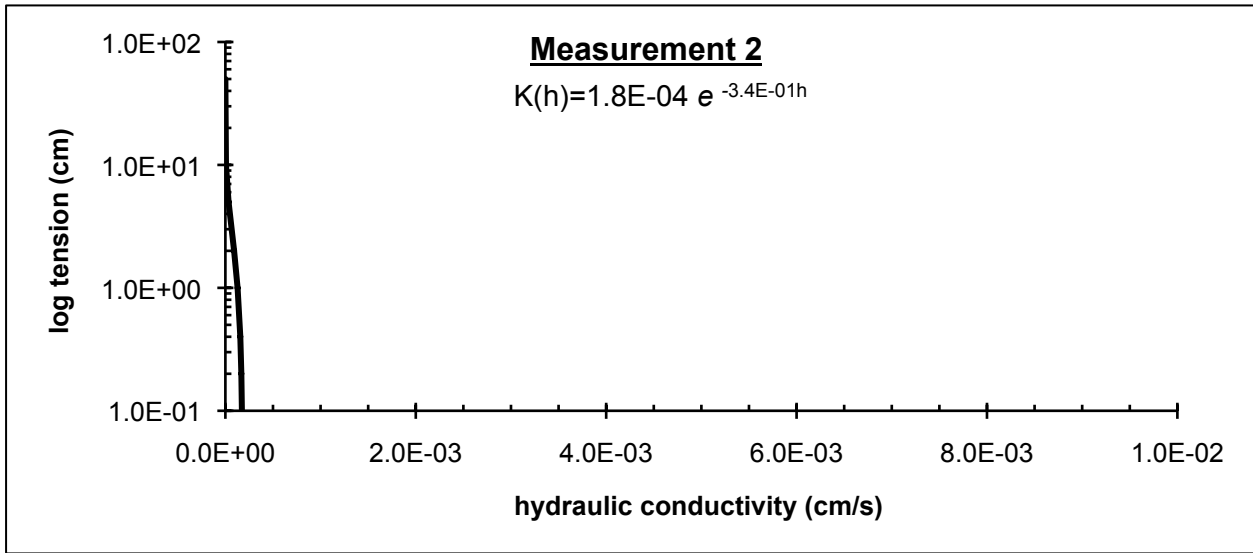

W3. Park at Joh Ave

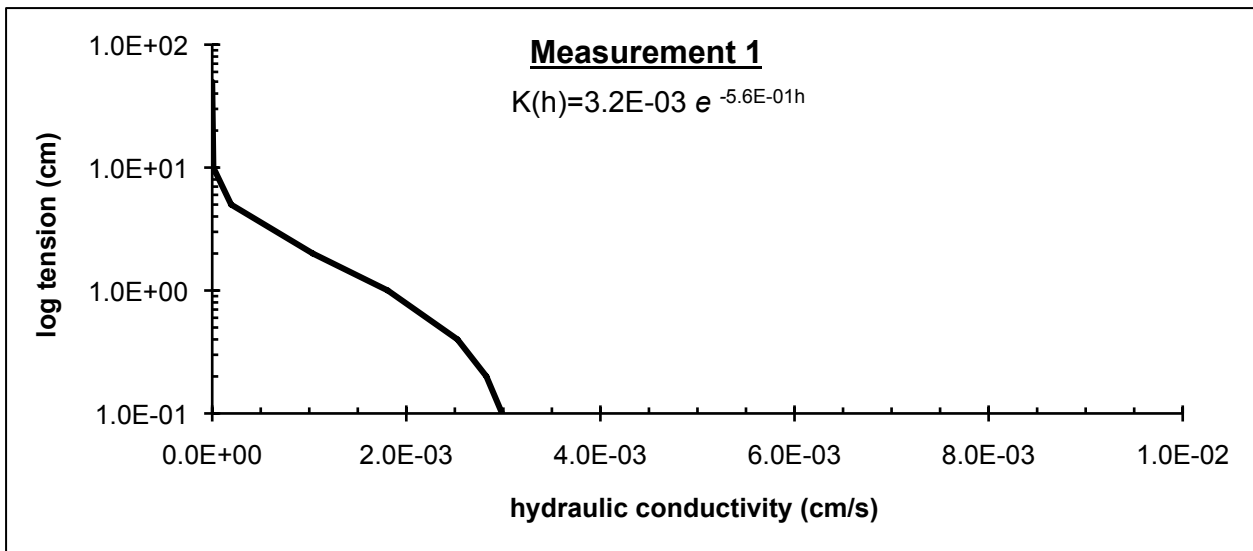
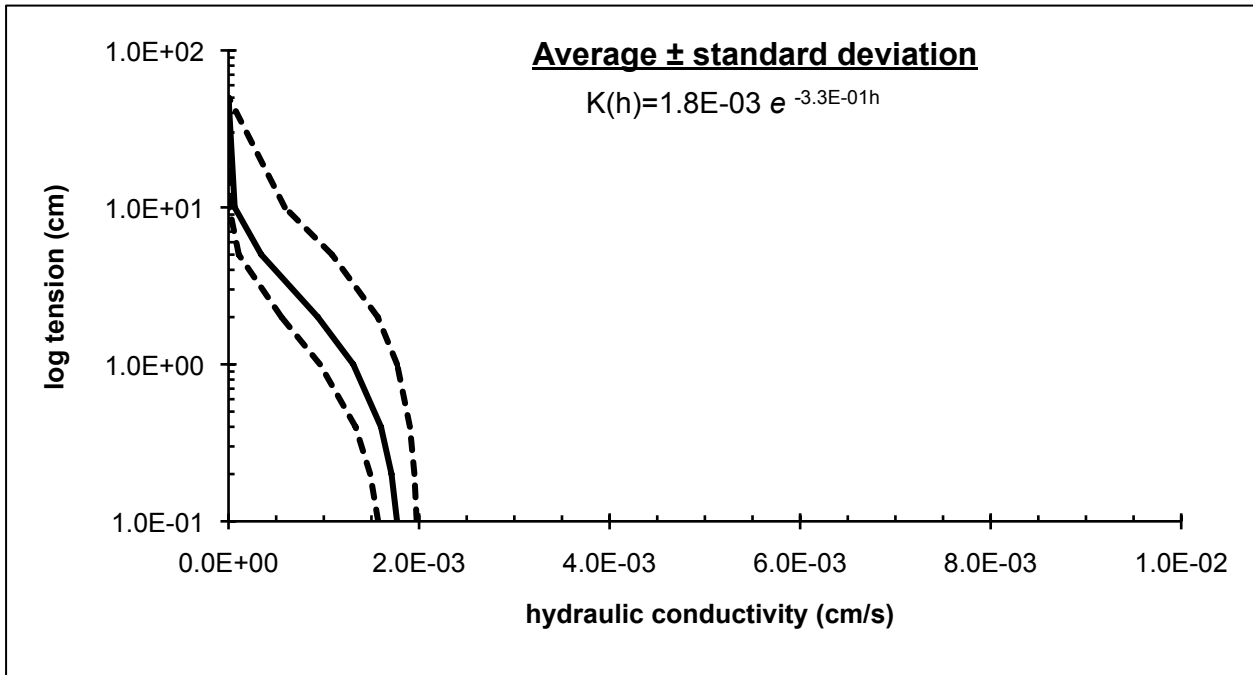

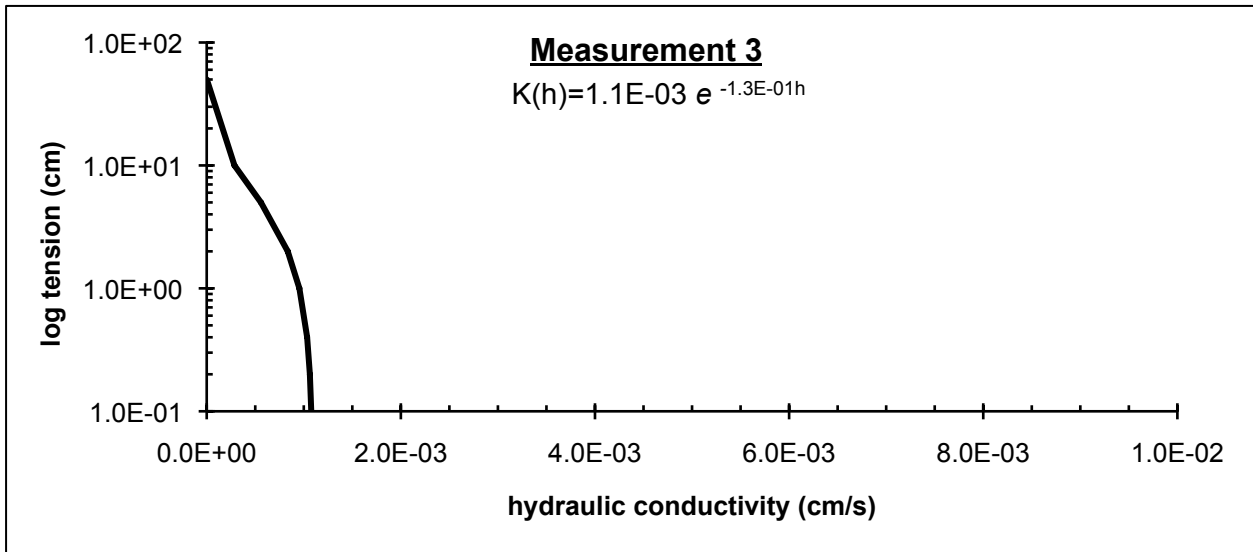
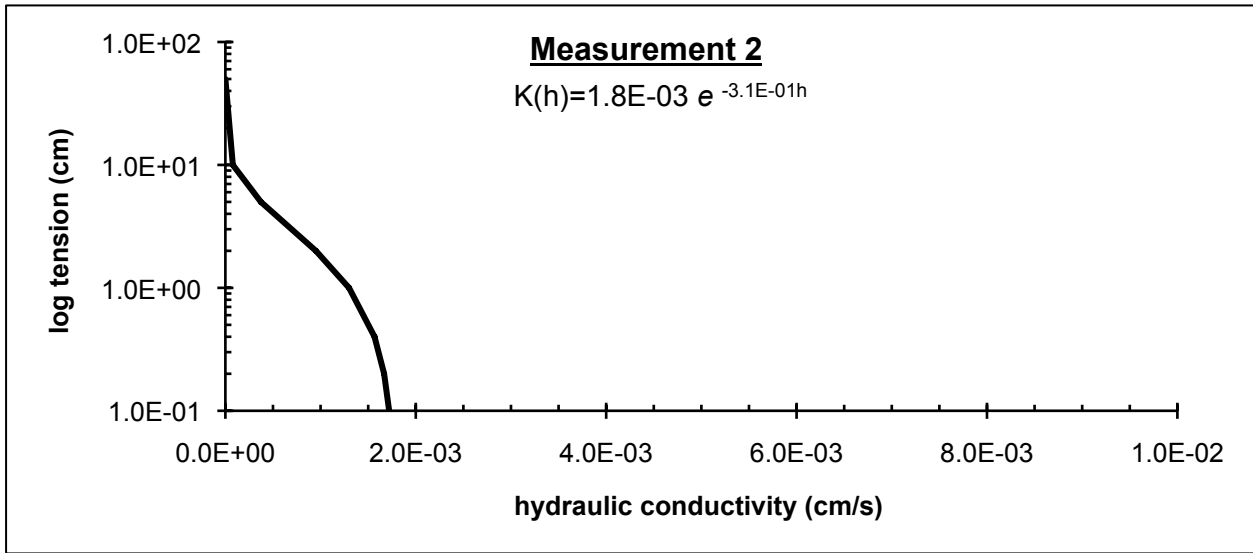

W4. Southwestern High School

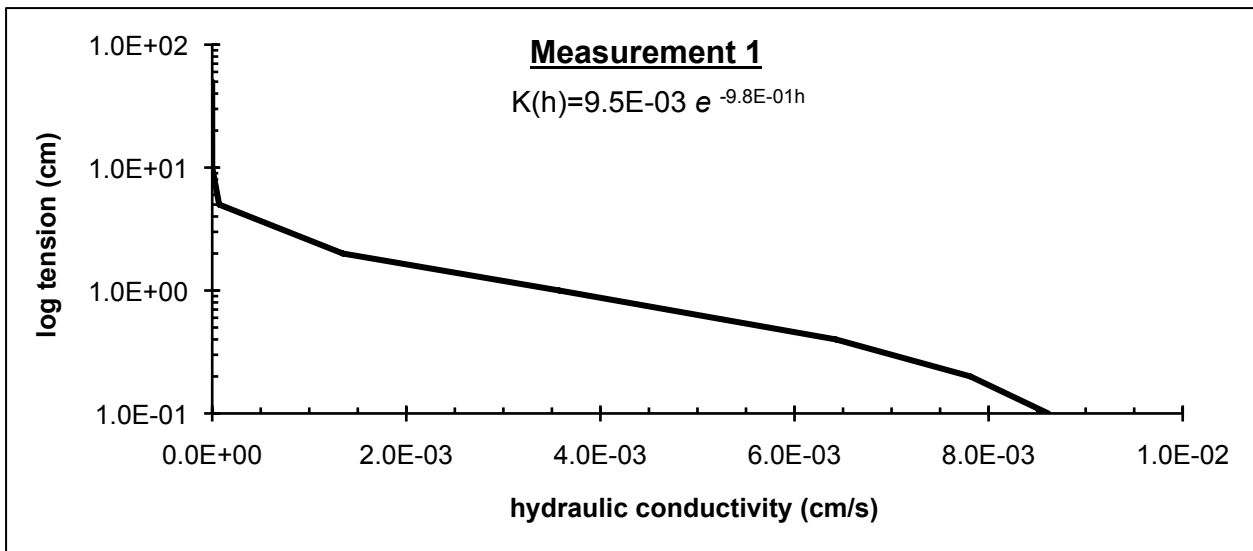
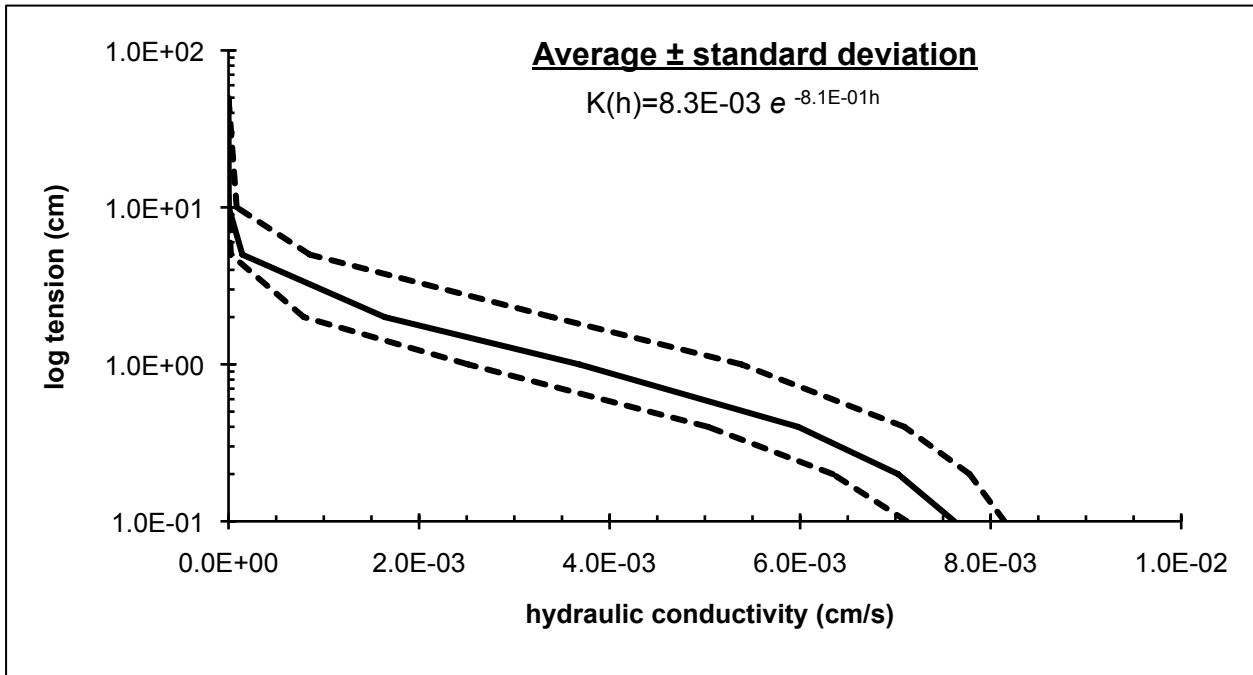

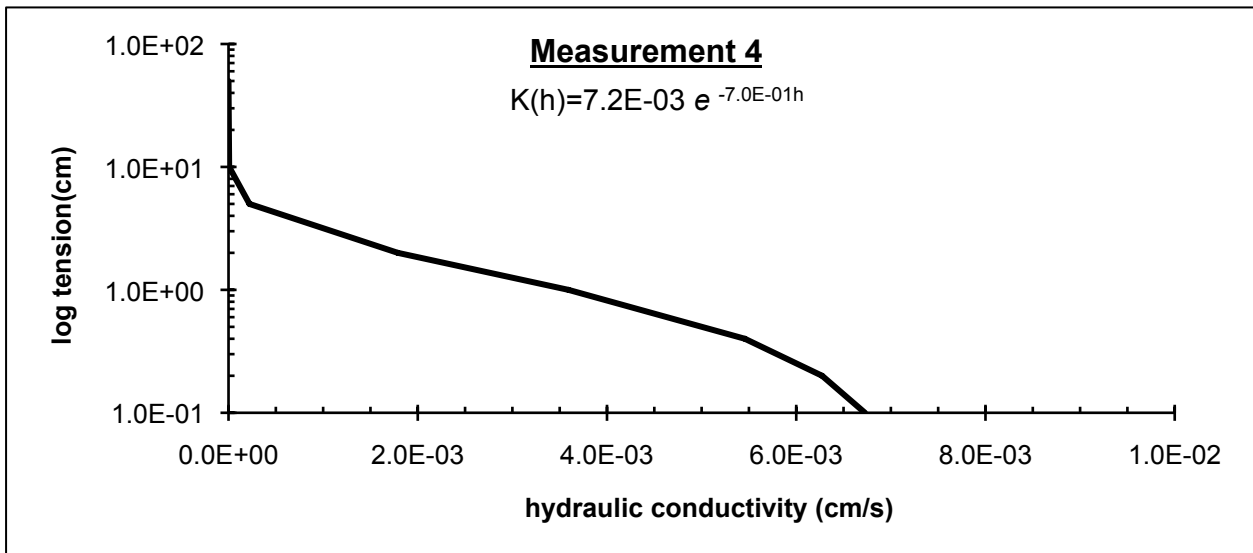
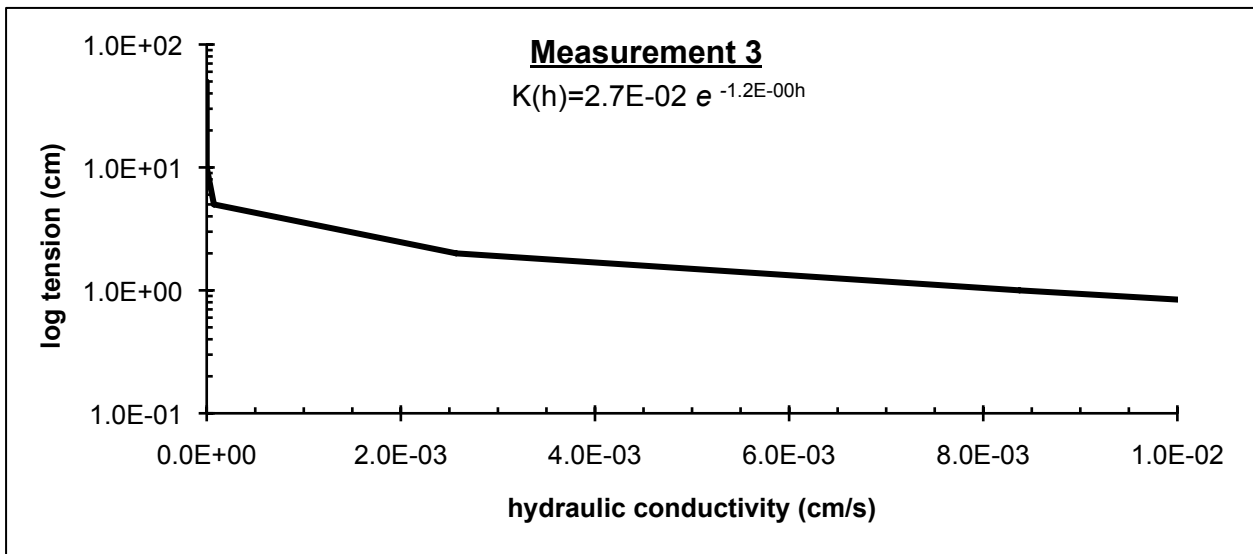
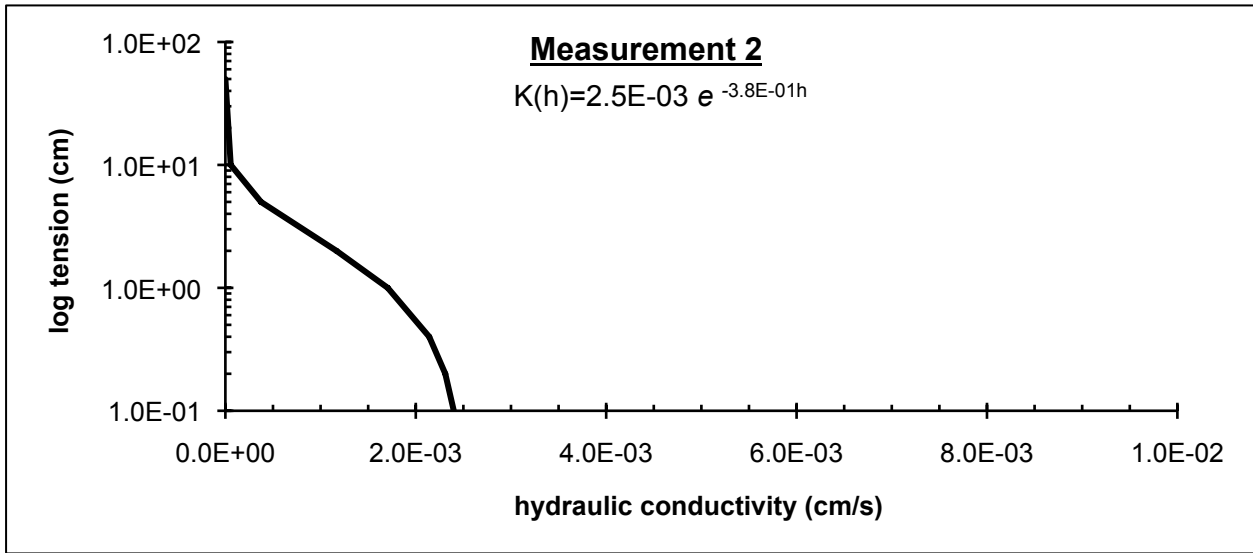

W6. Whitfield Rd at Academy Rd

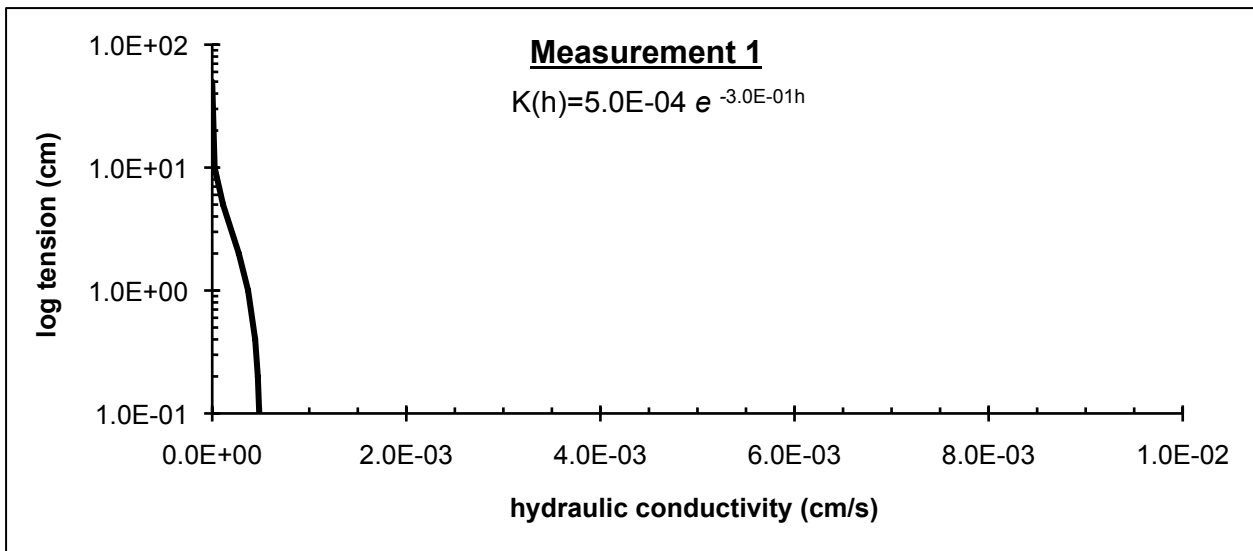
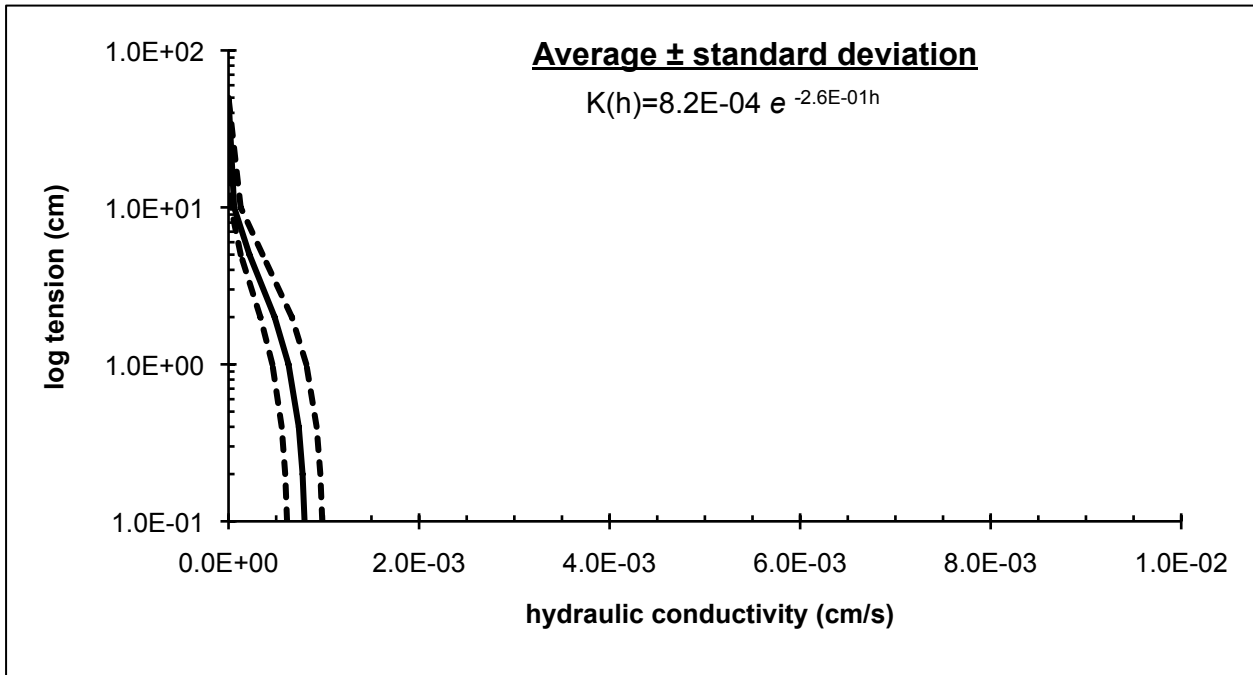

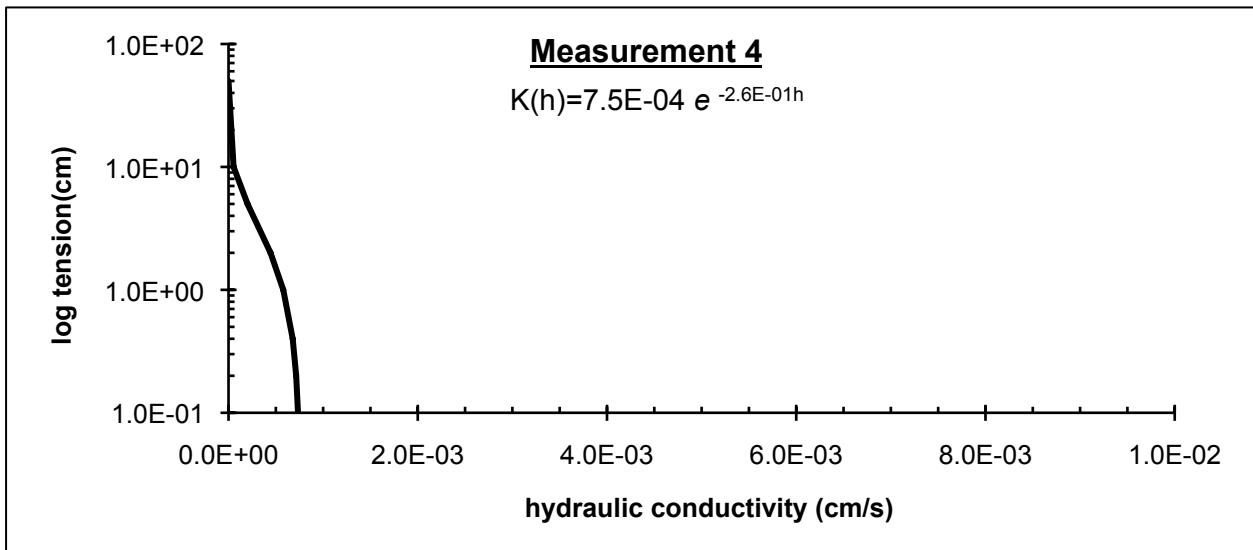
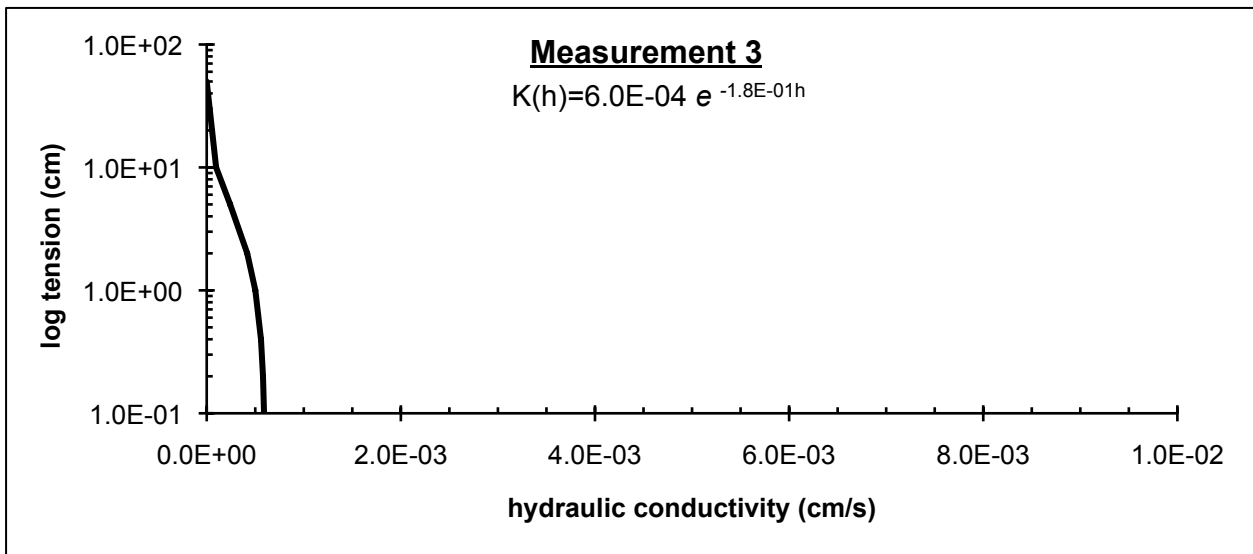
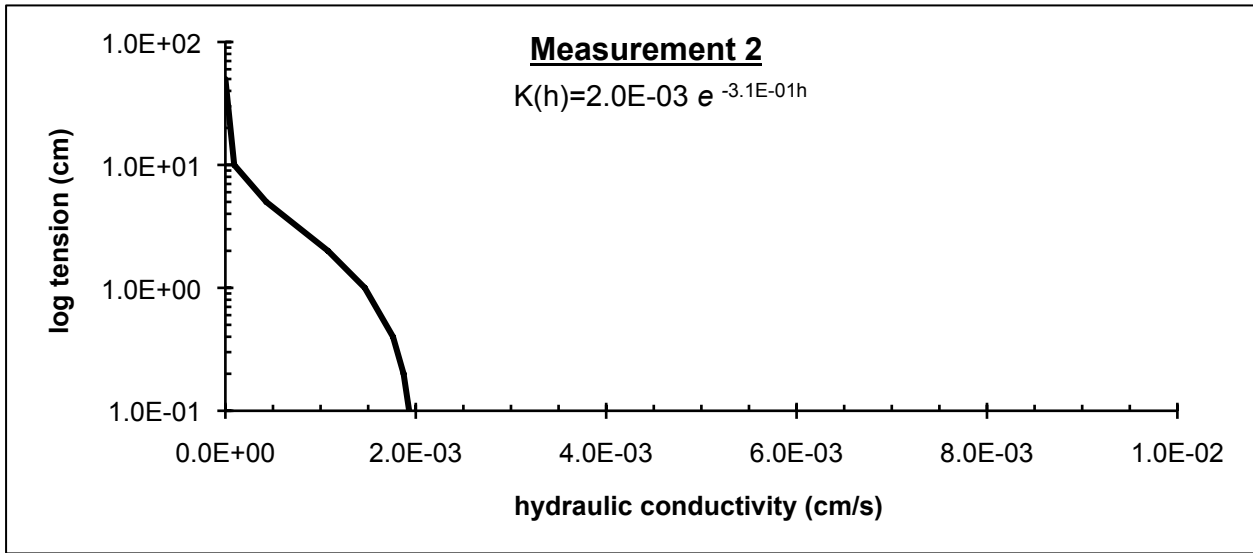

W9. Robert Coleman Elementary School

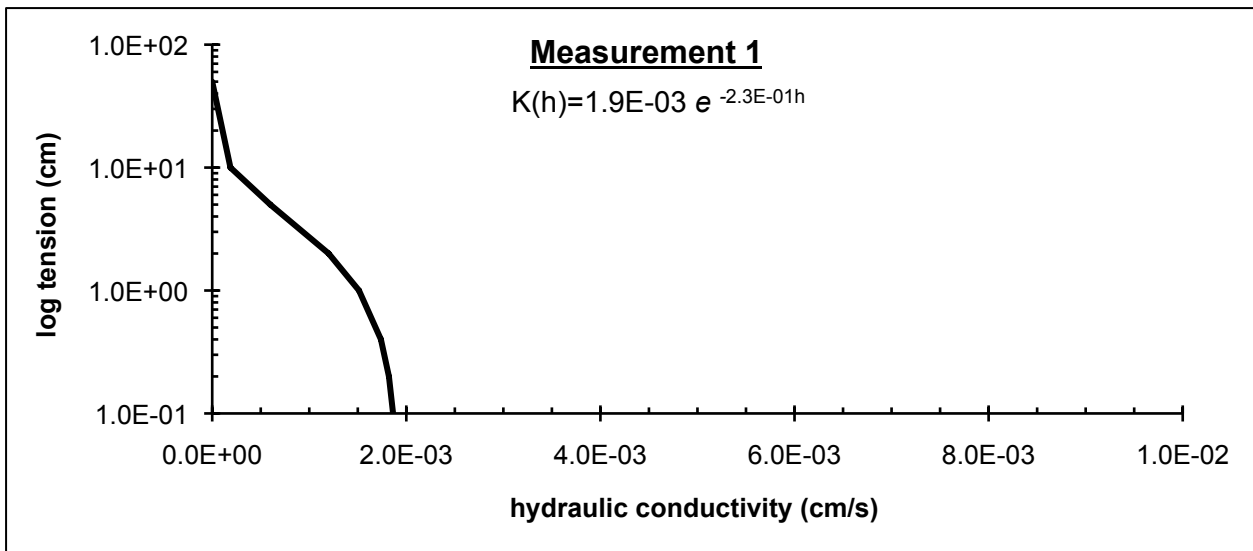
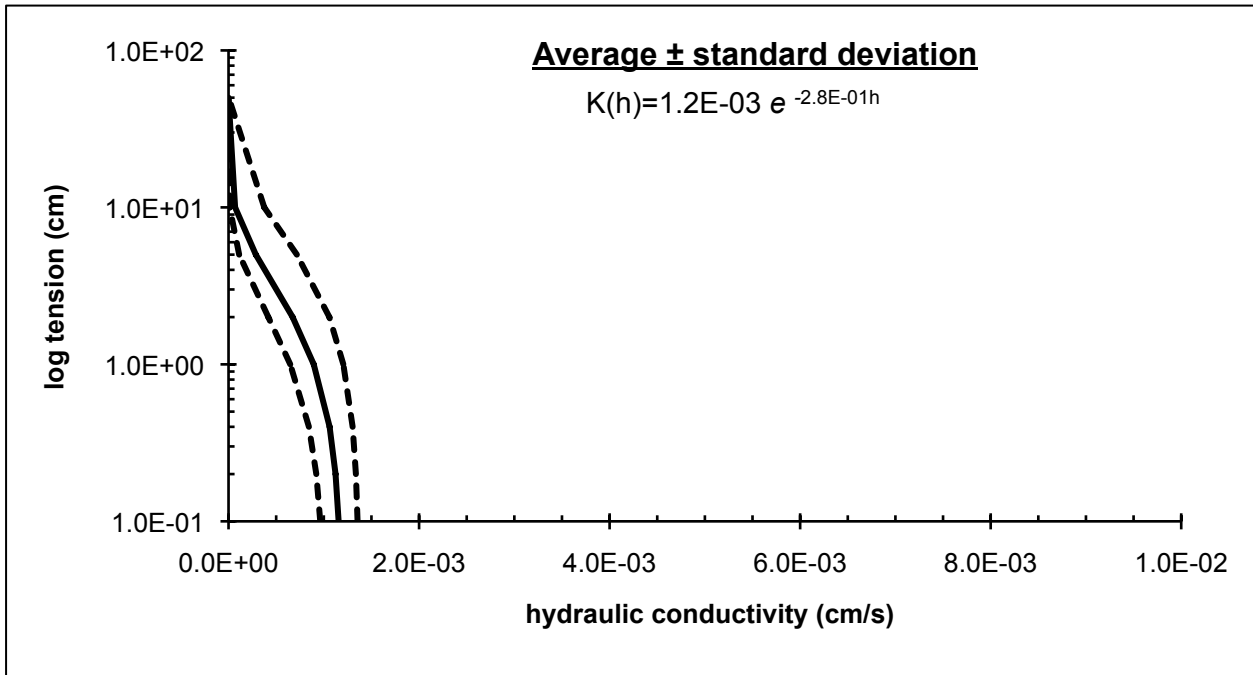

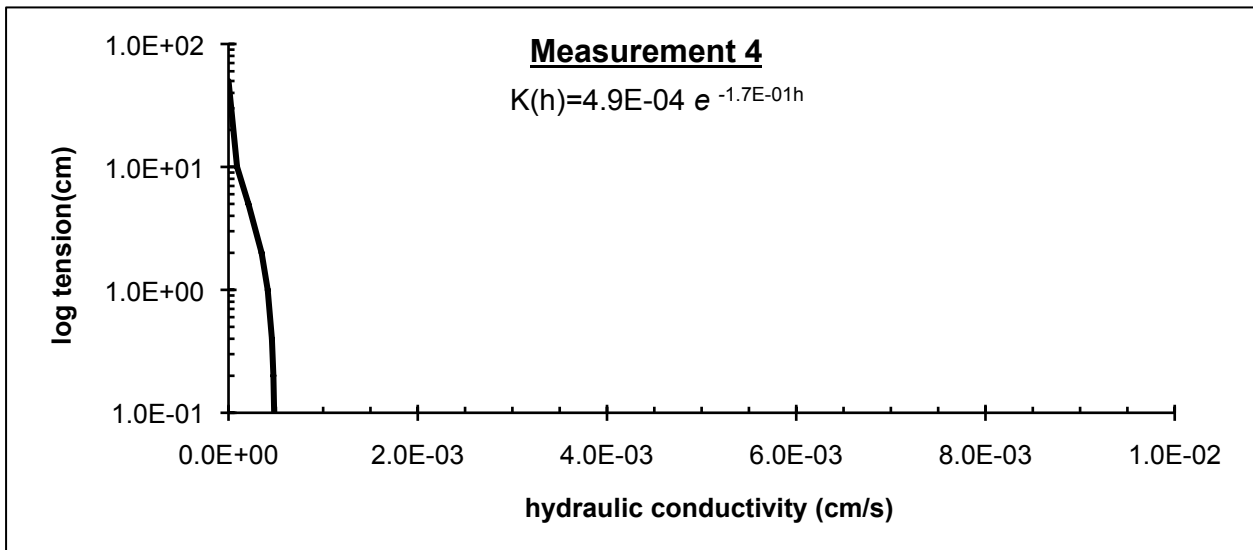
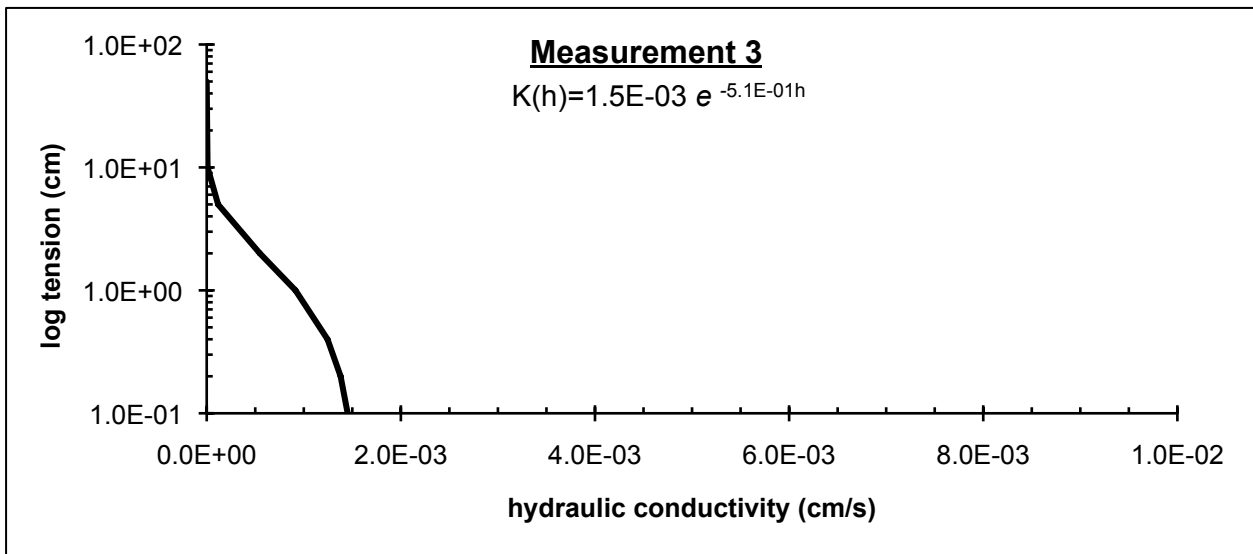
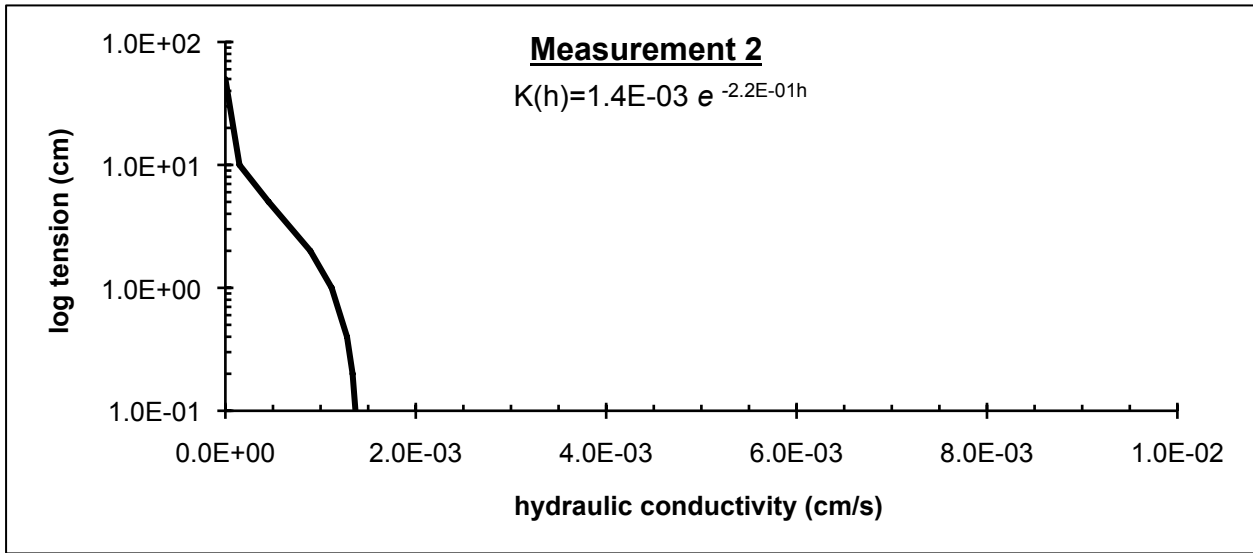

W10. Westview Park

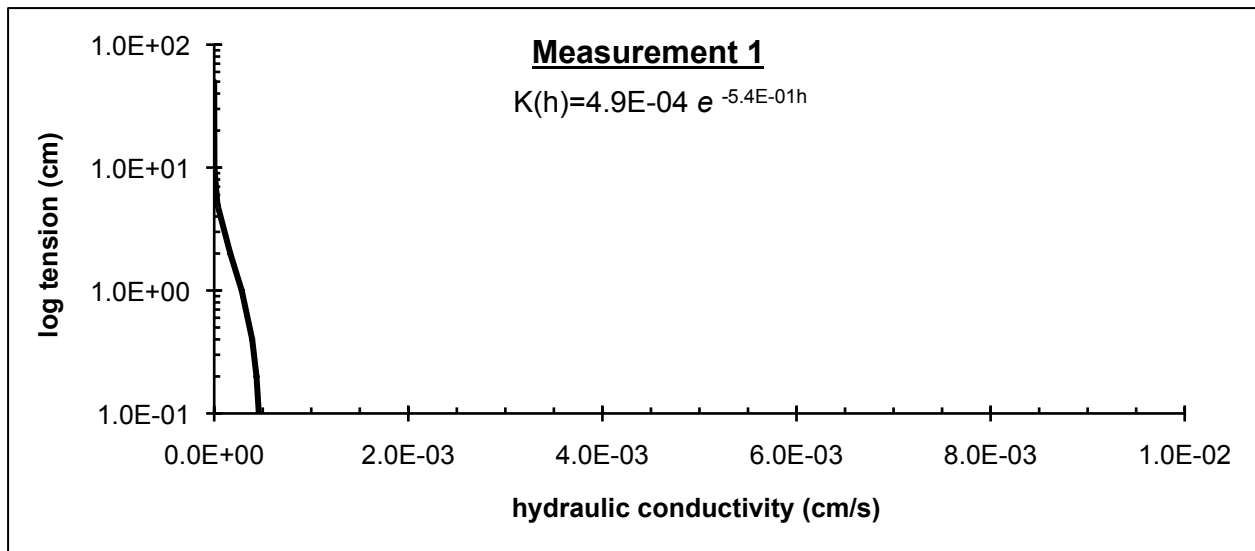
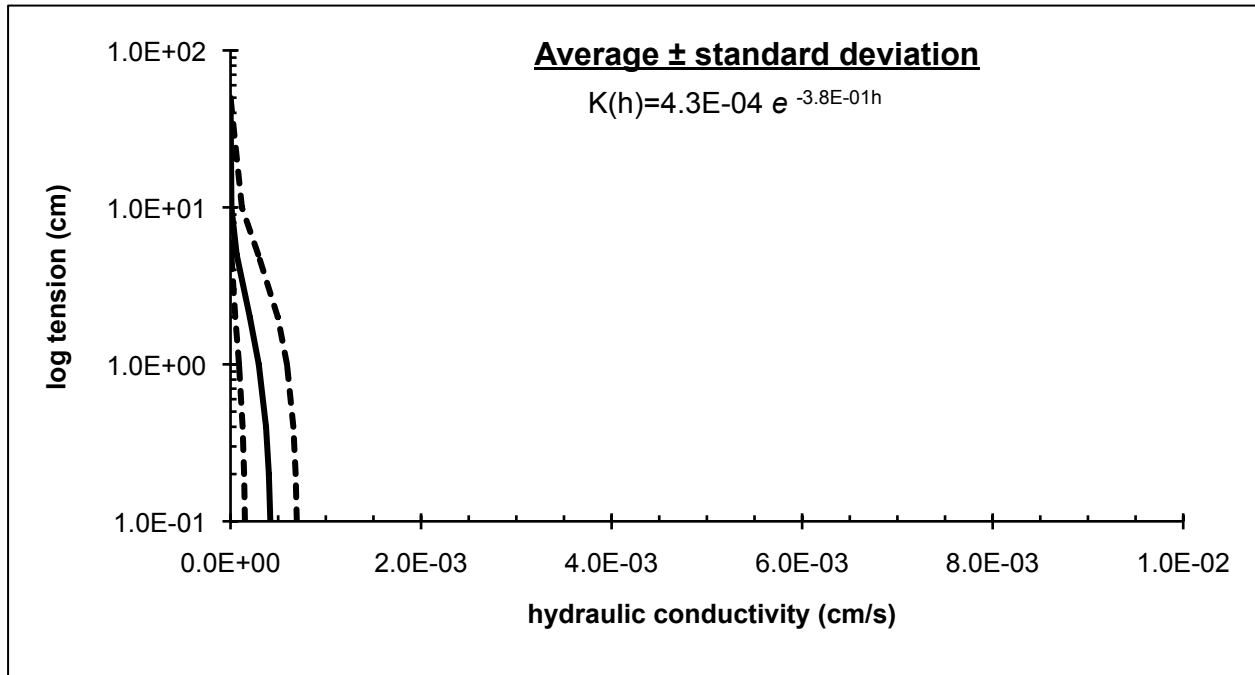

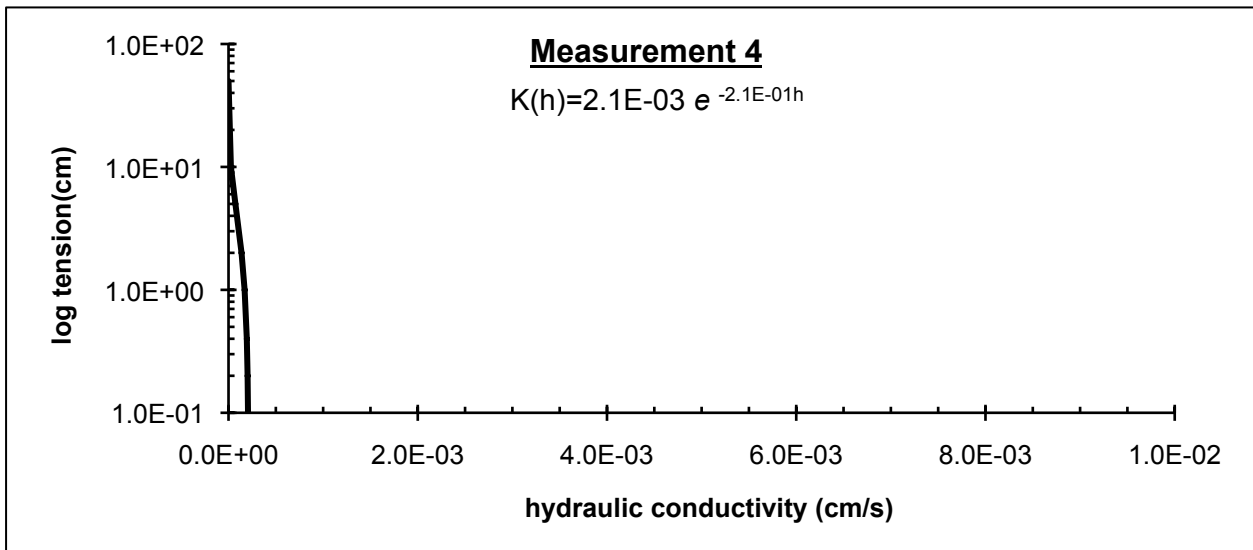
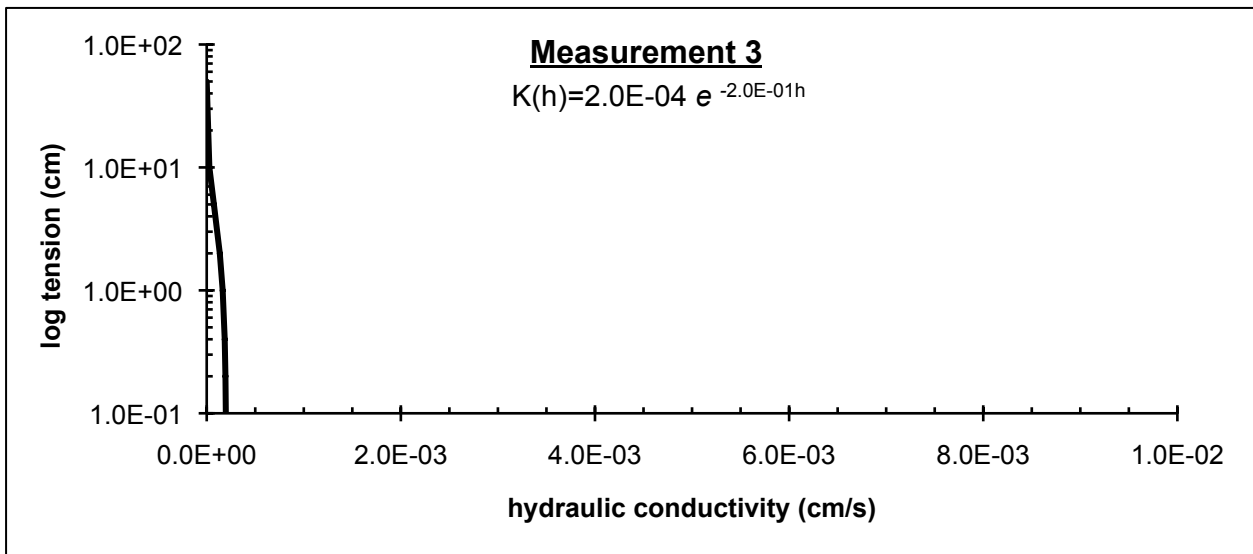
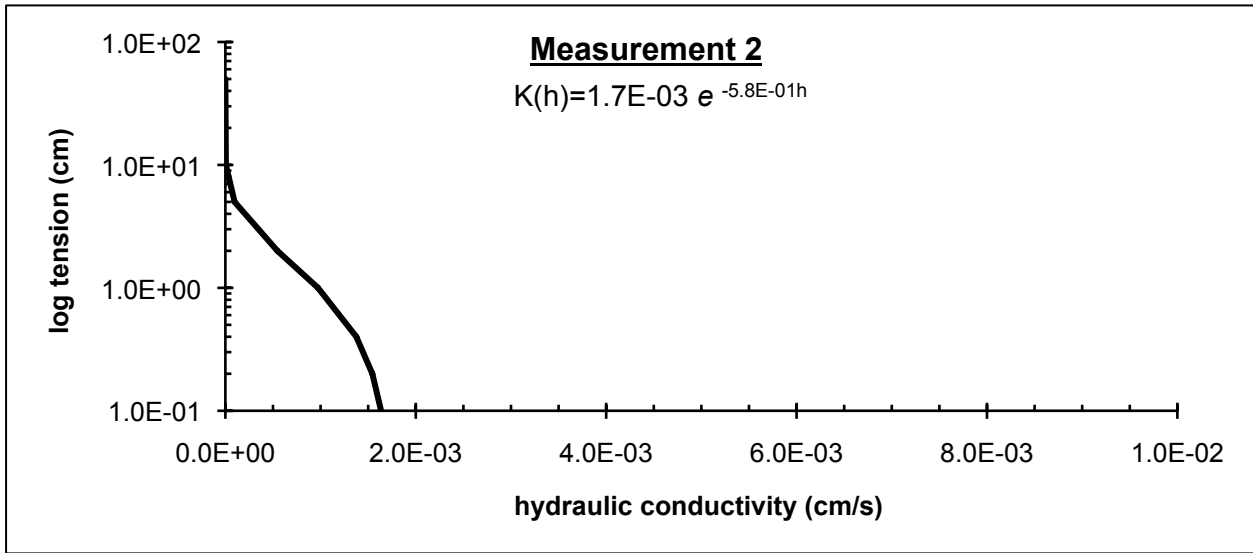

W11. Edmonson Heights Park

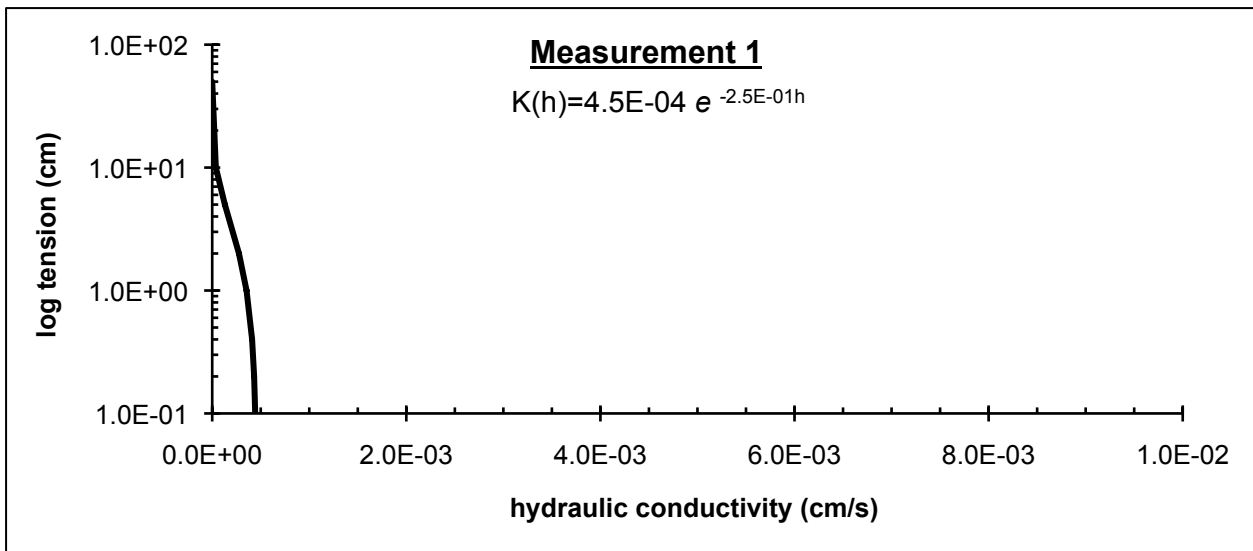
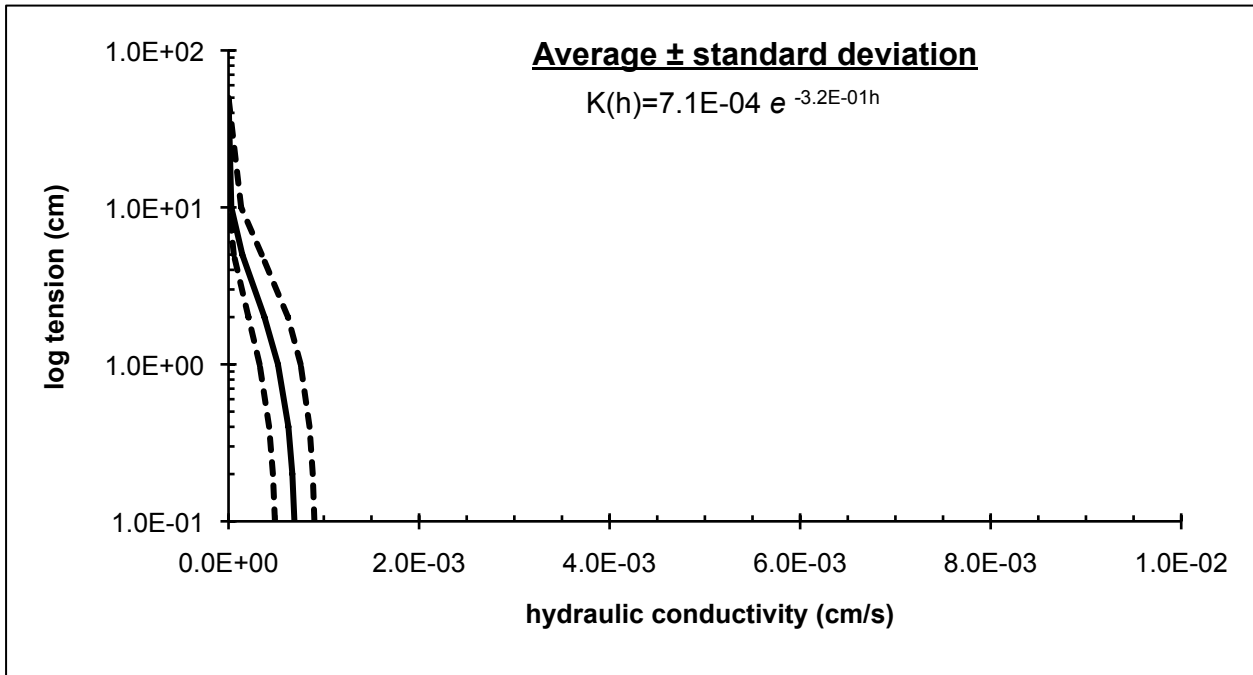

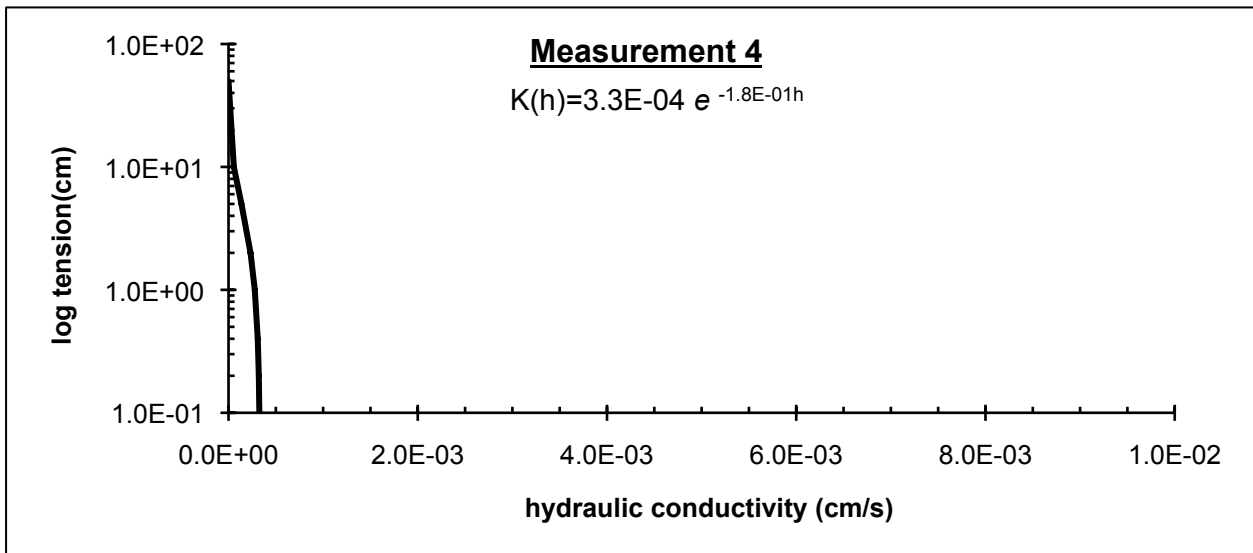
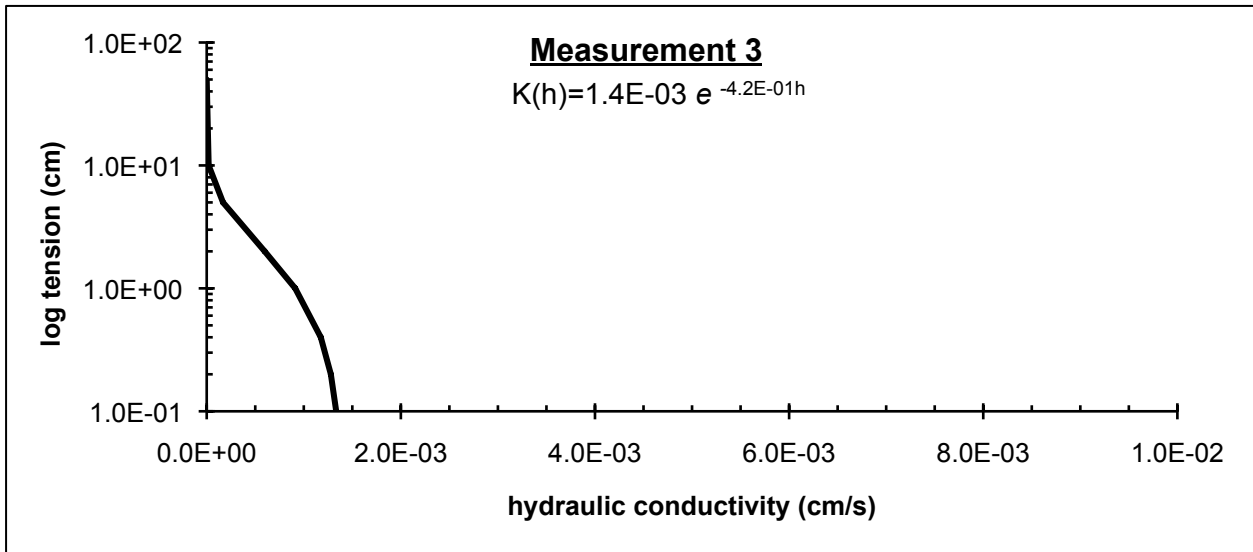
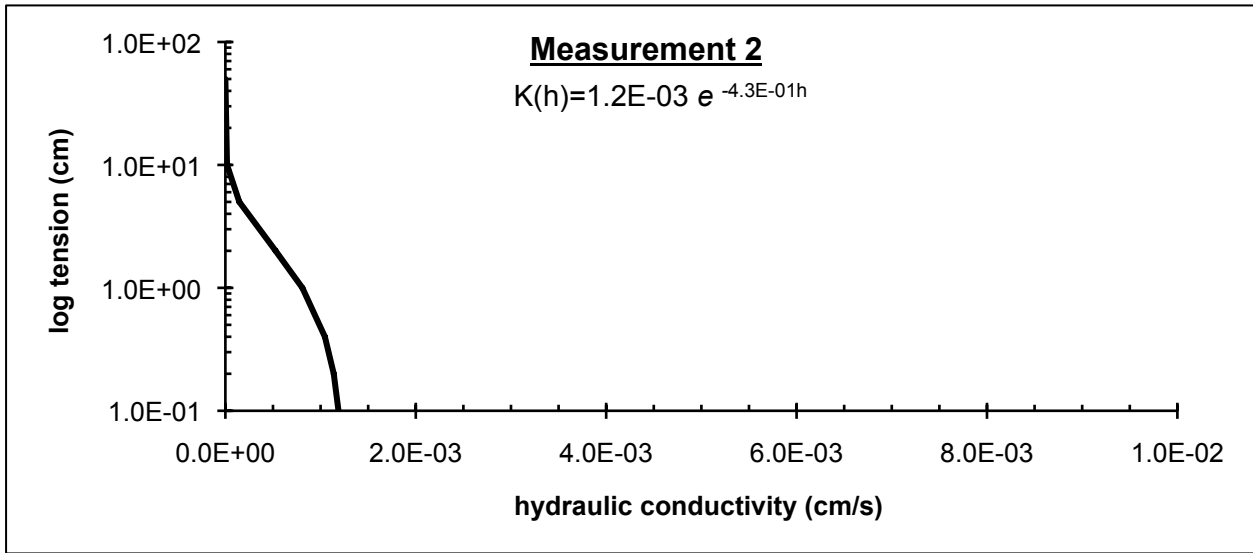

W12. Leakin Park

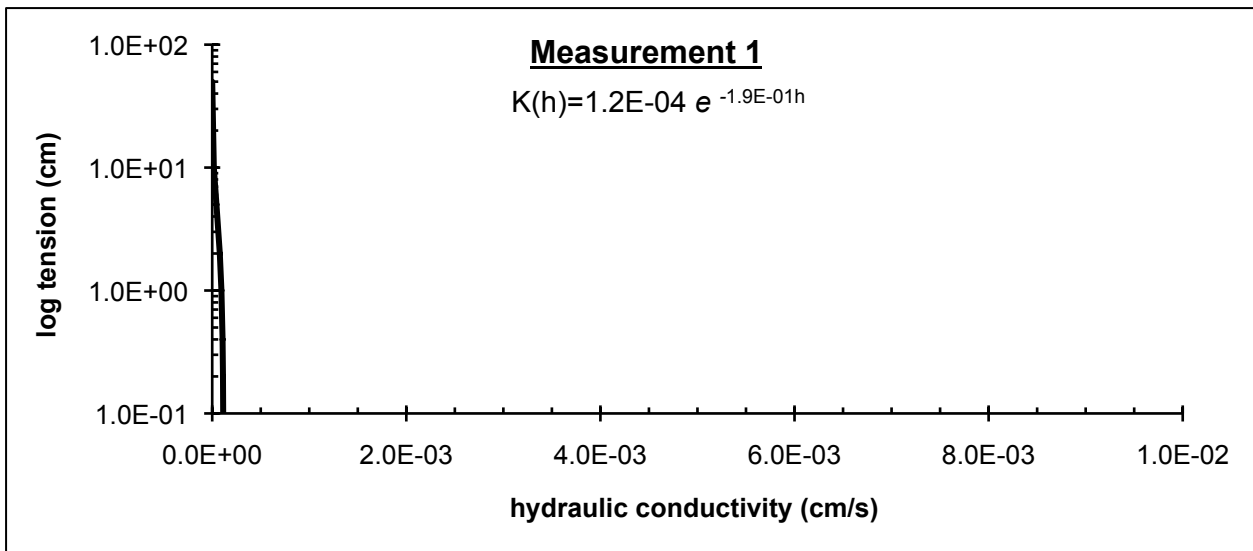
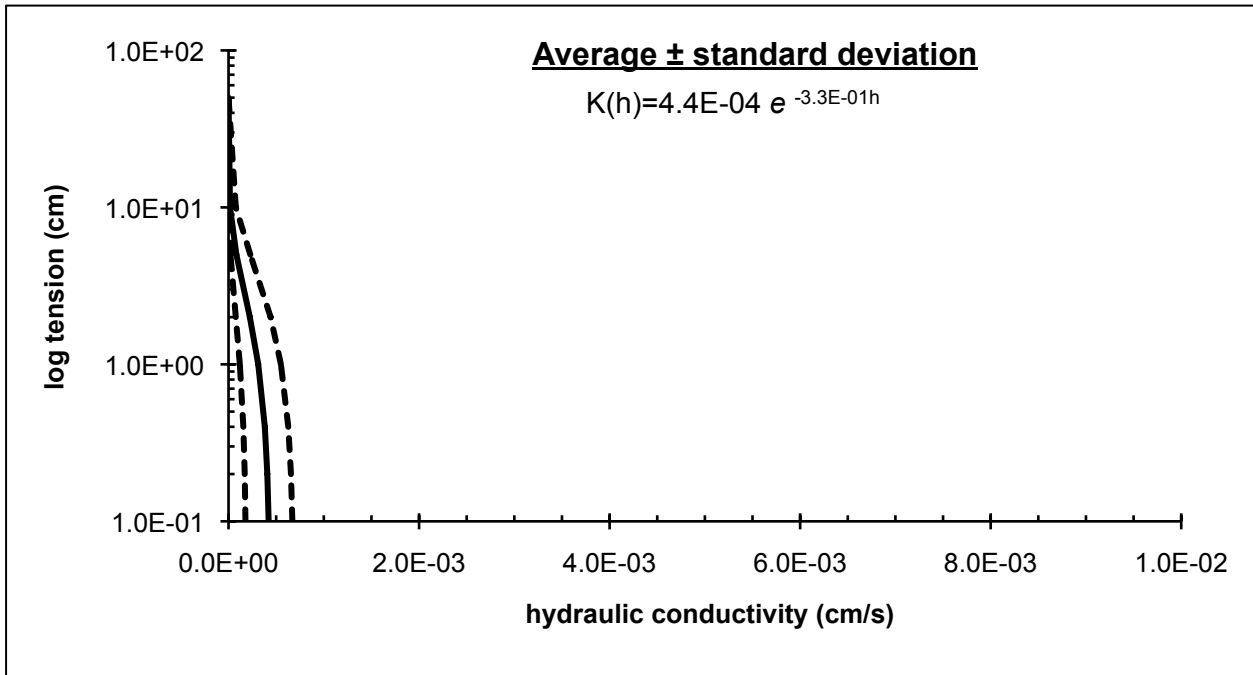

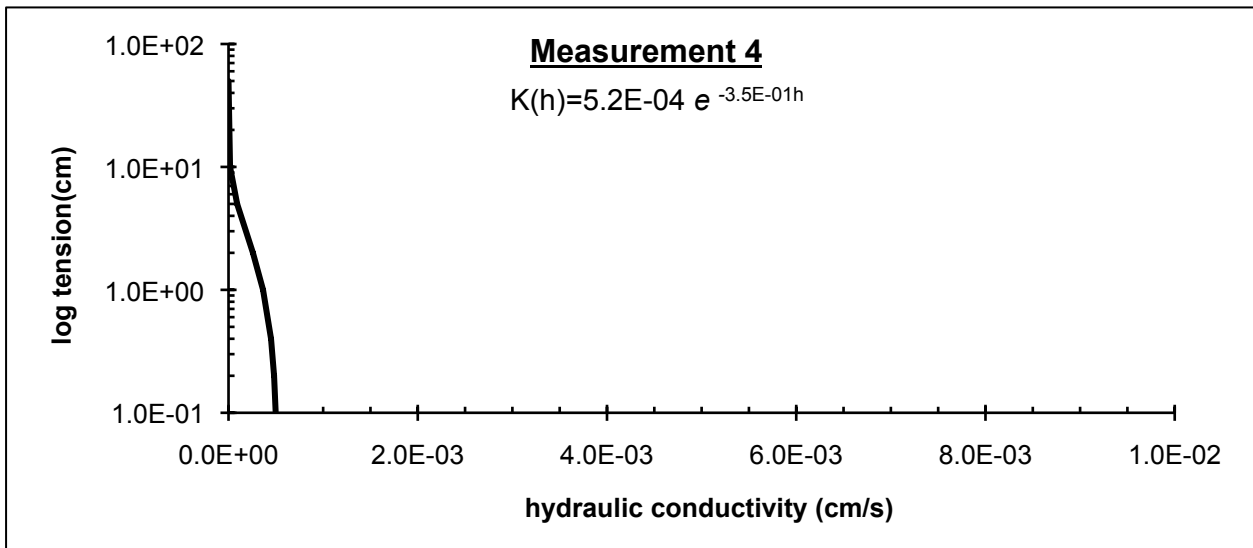
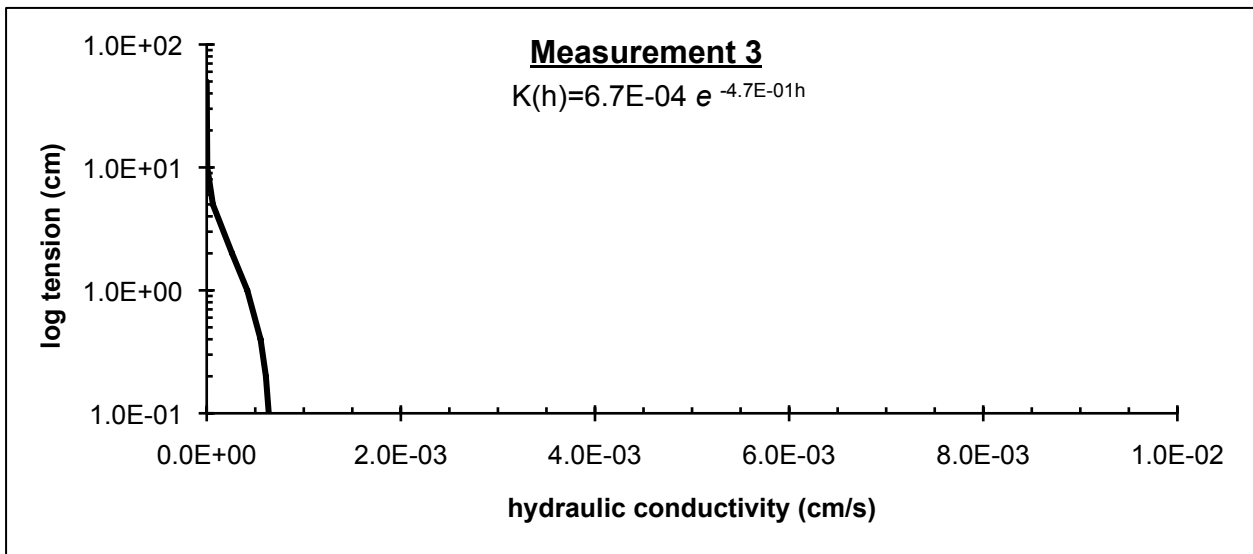
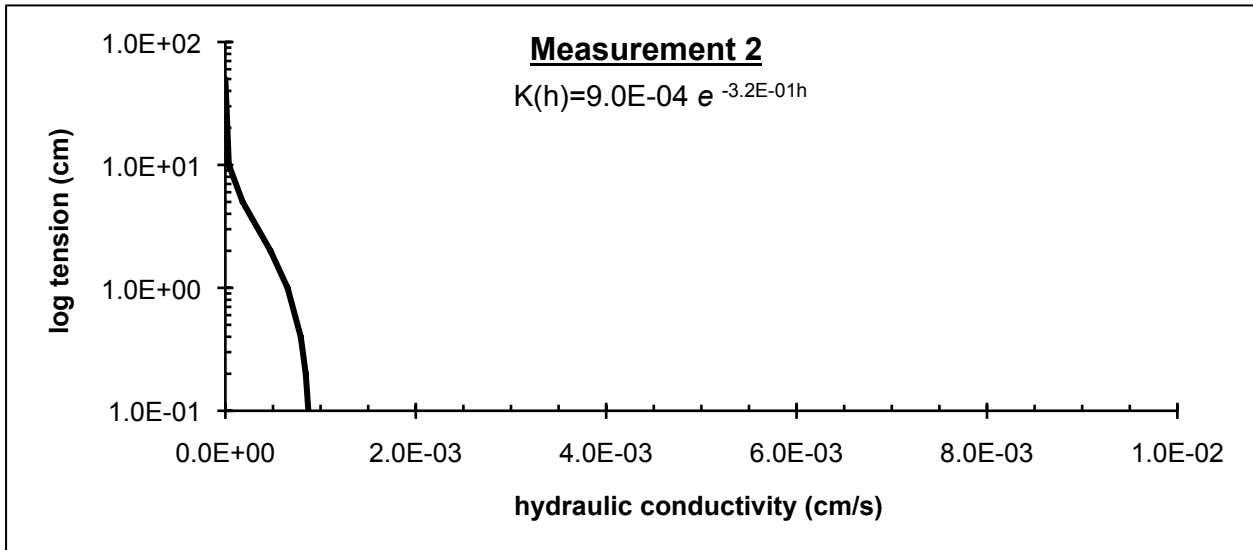

W13. Windsor Hill Elementary School

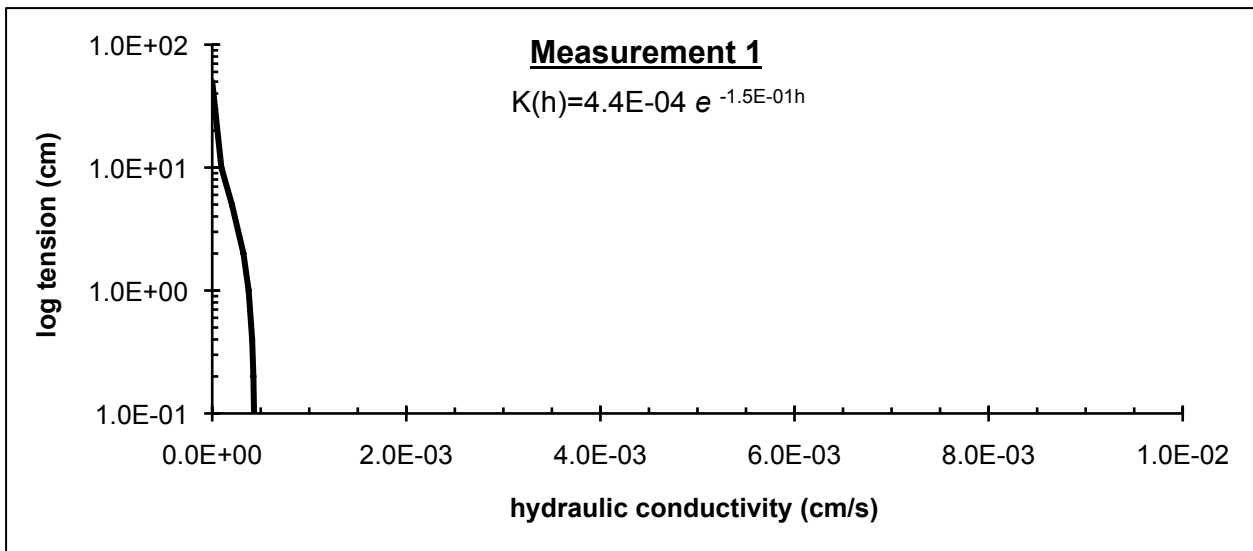
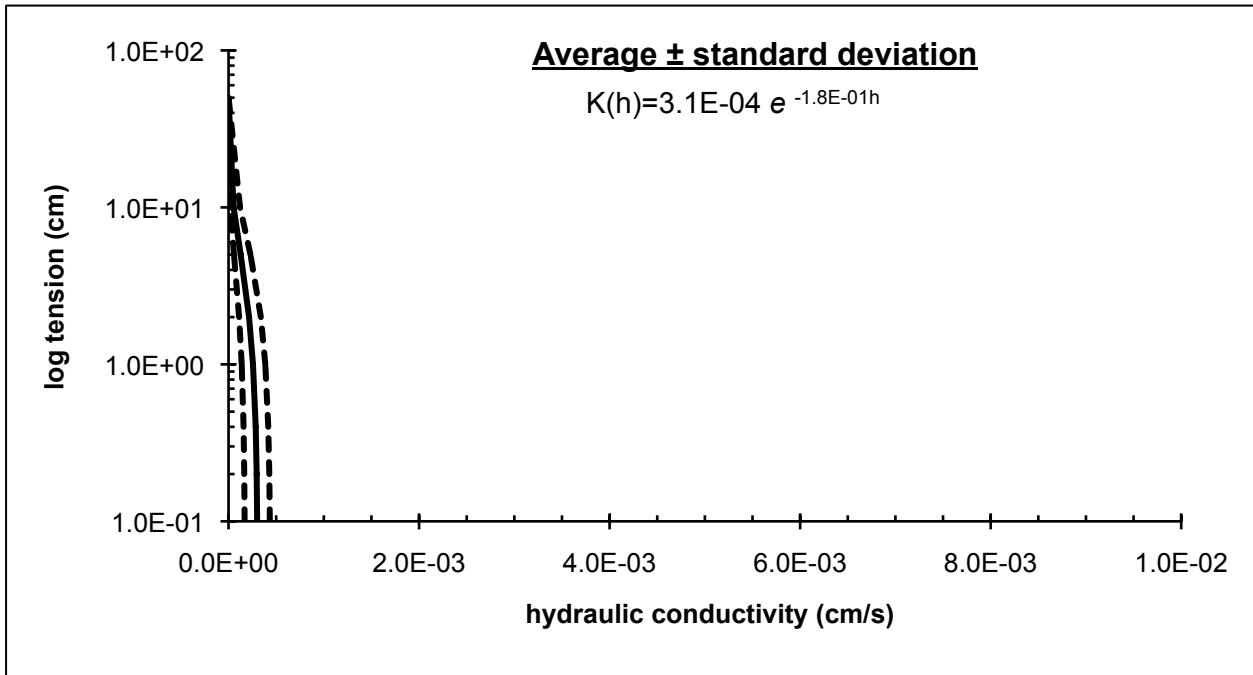

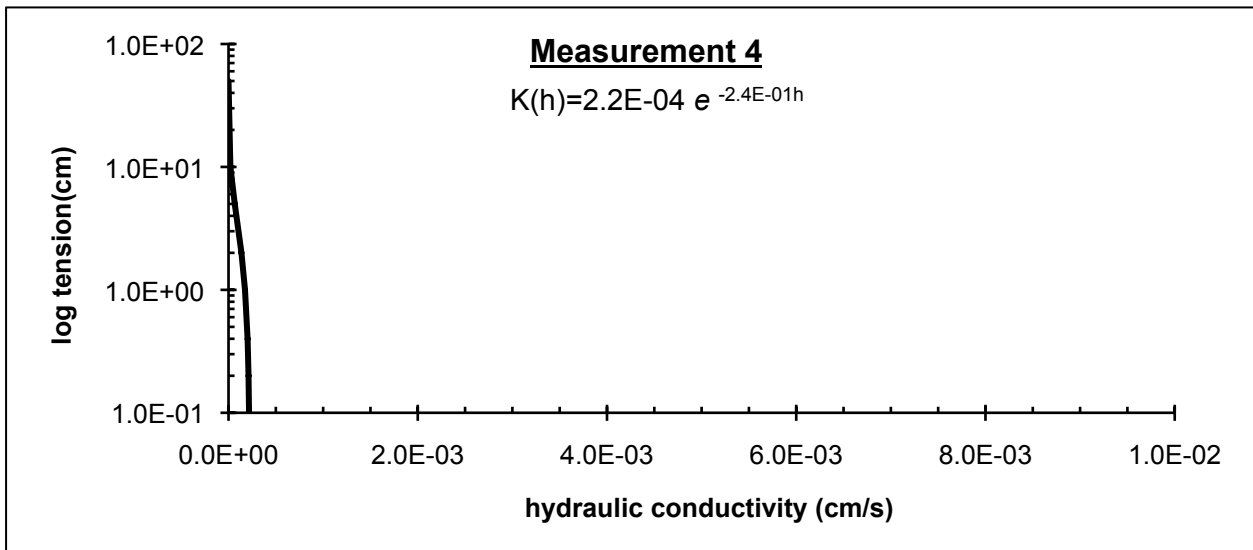
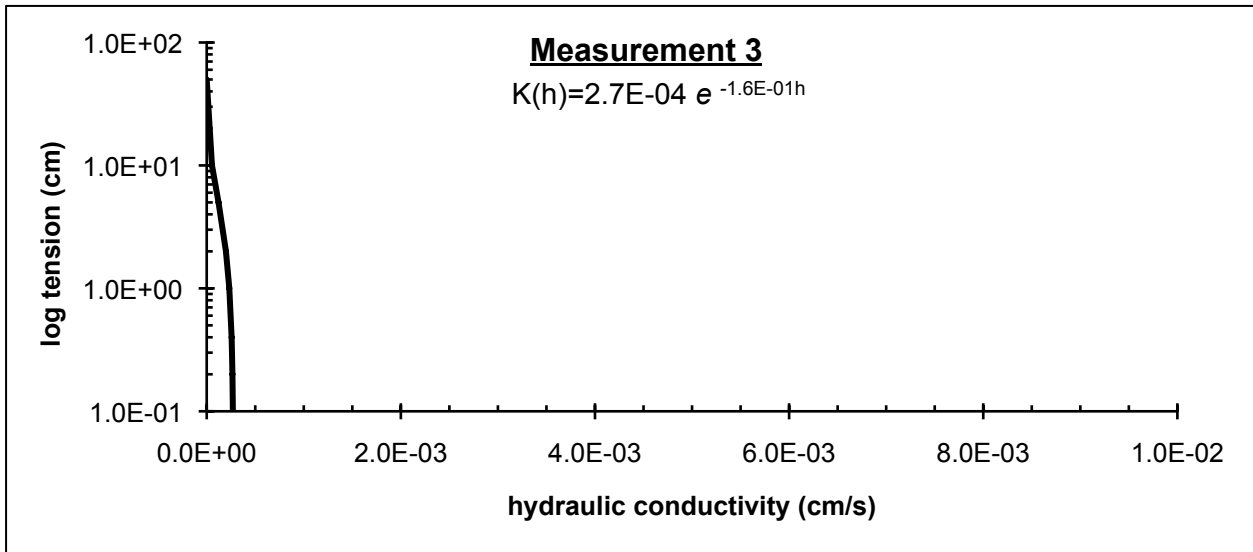
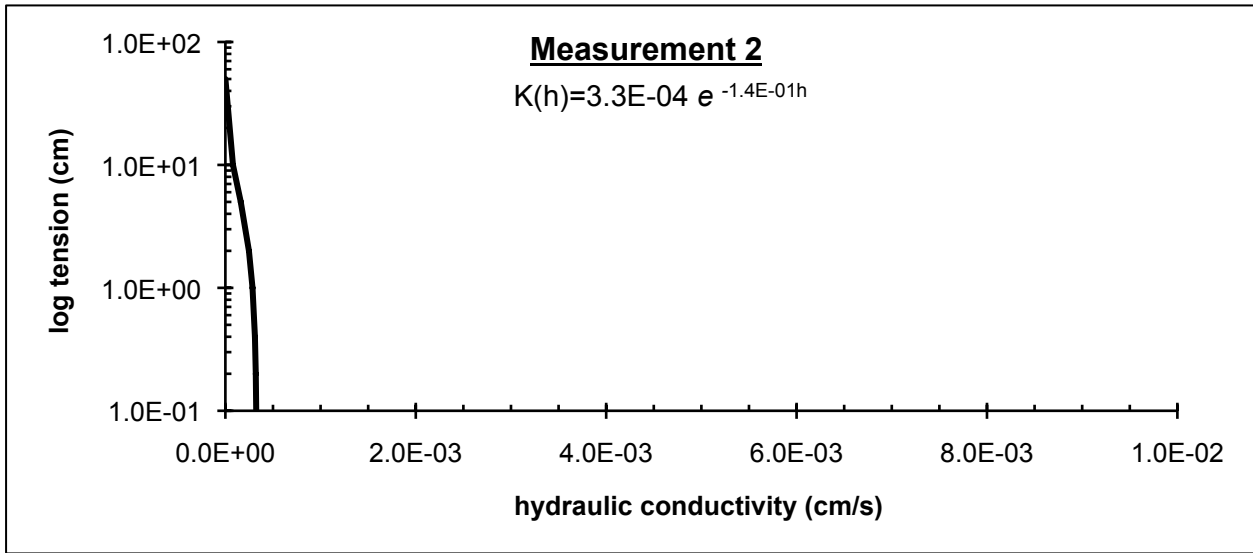

W14. Hanlon Park

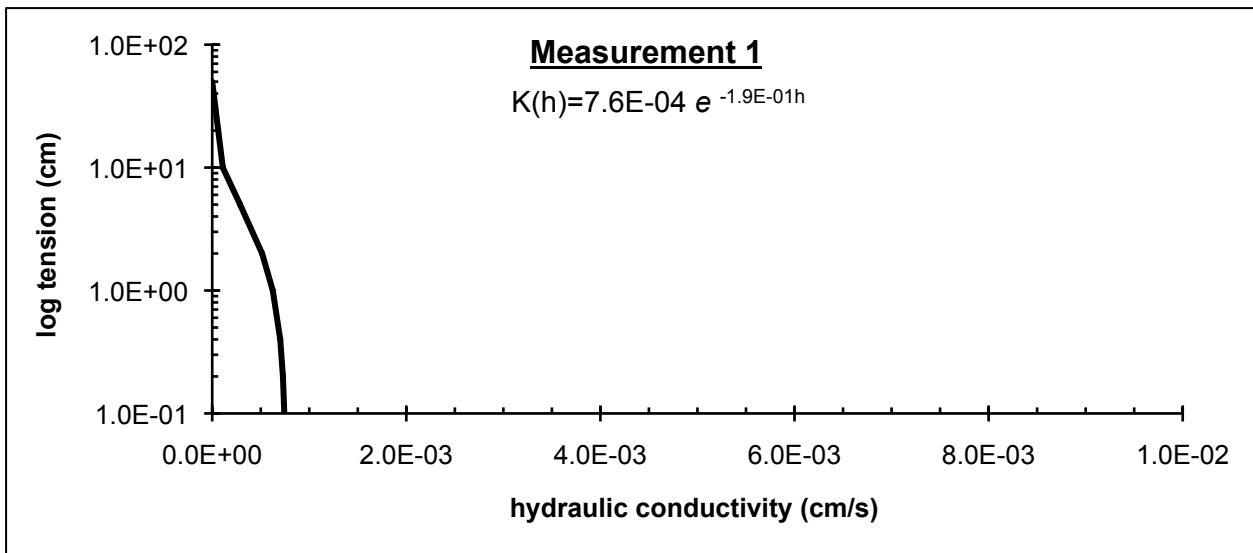
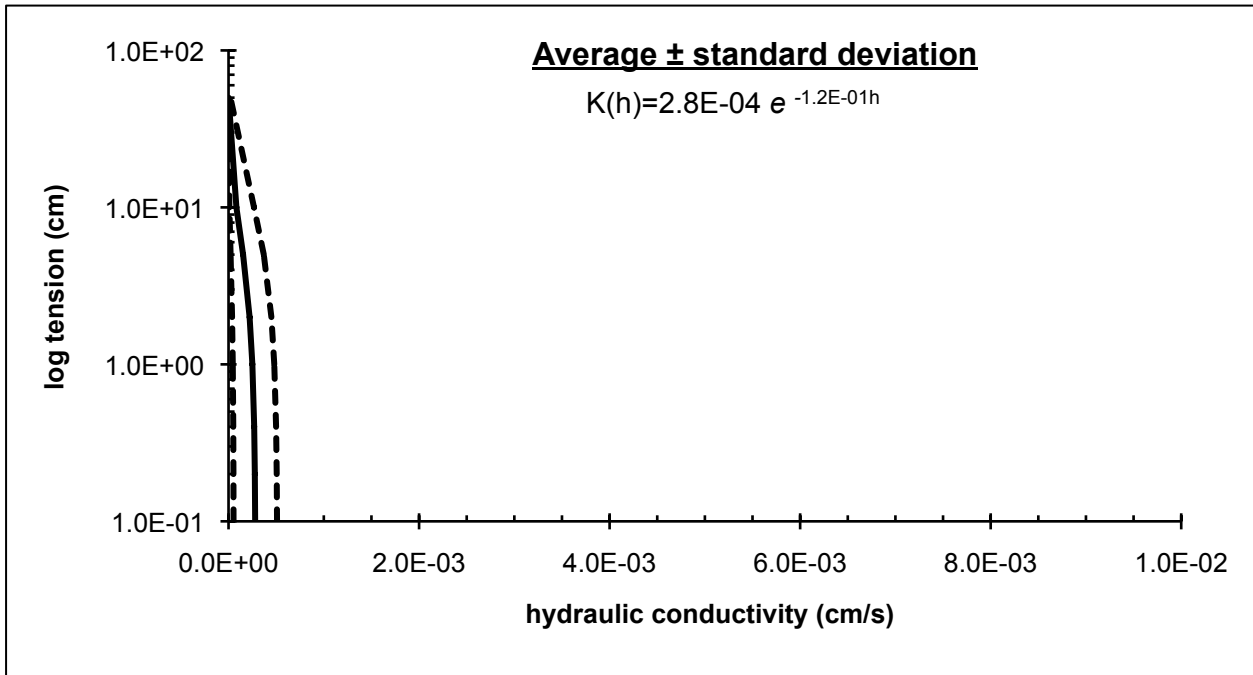

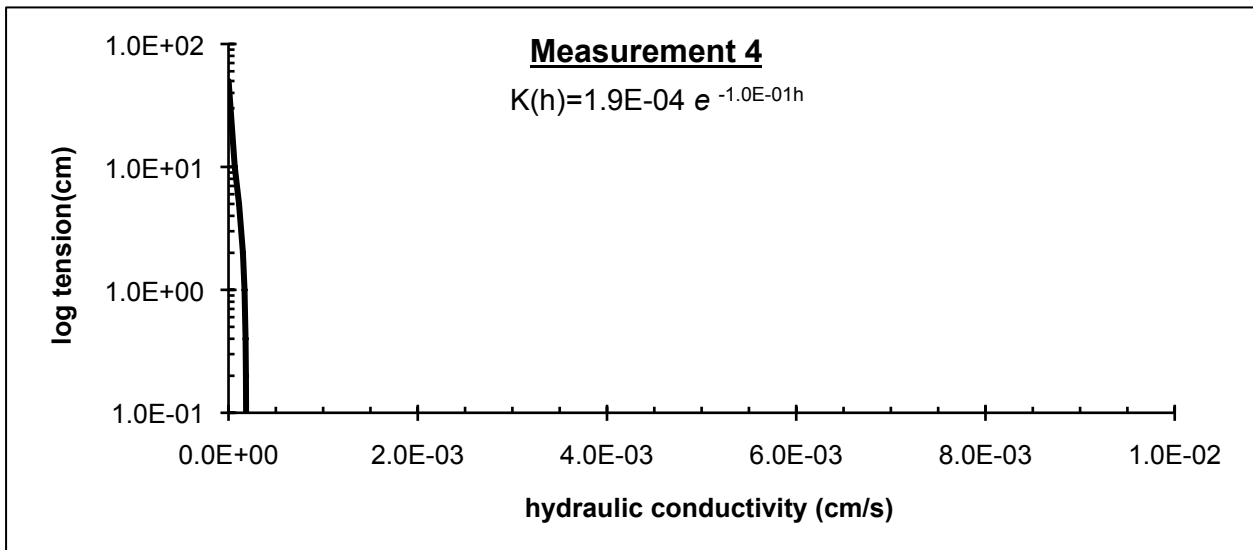
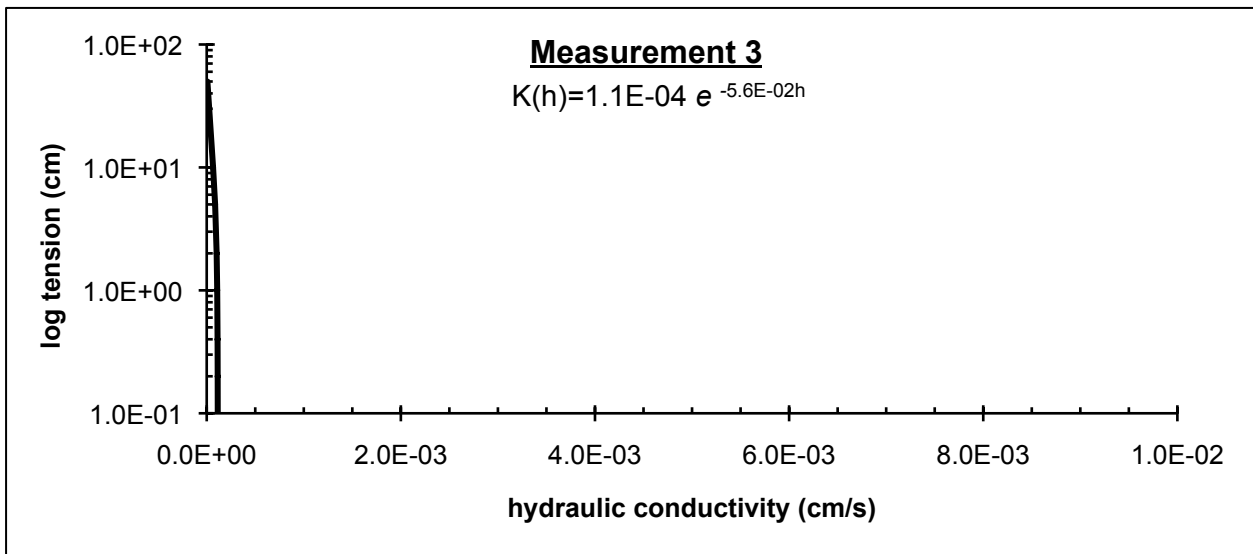
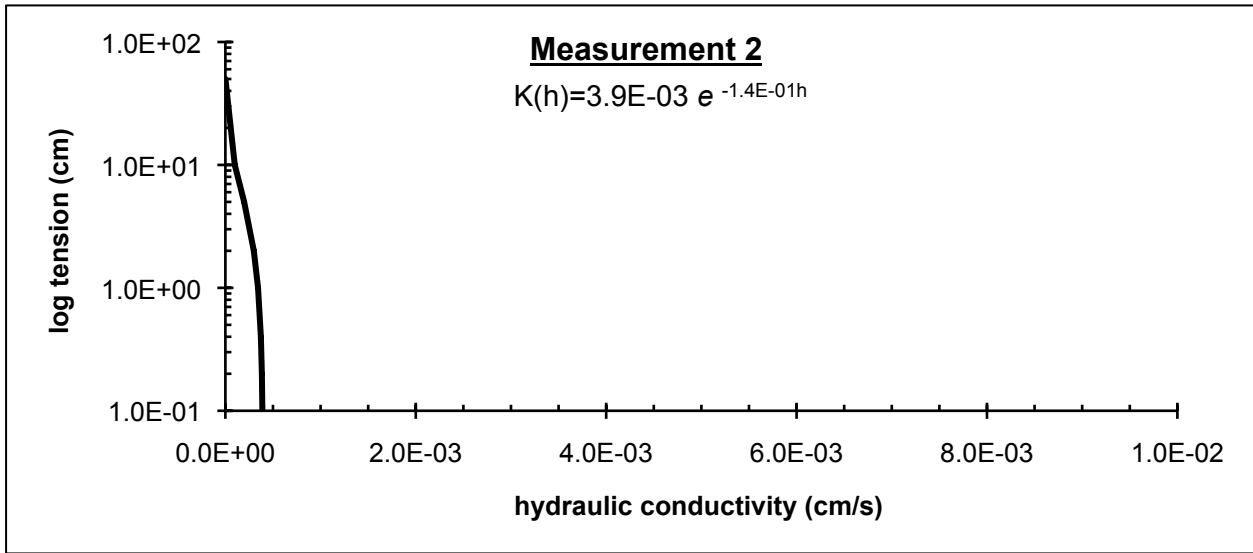

W16. Burnside Memorial Park

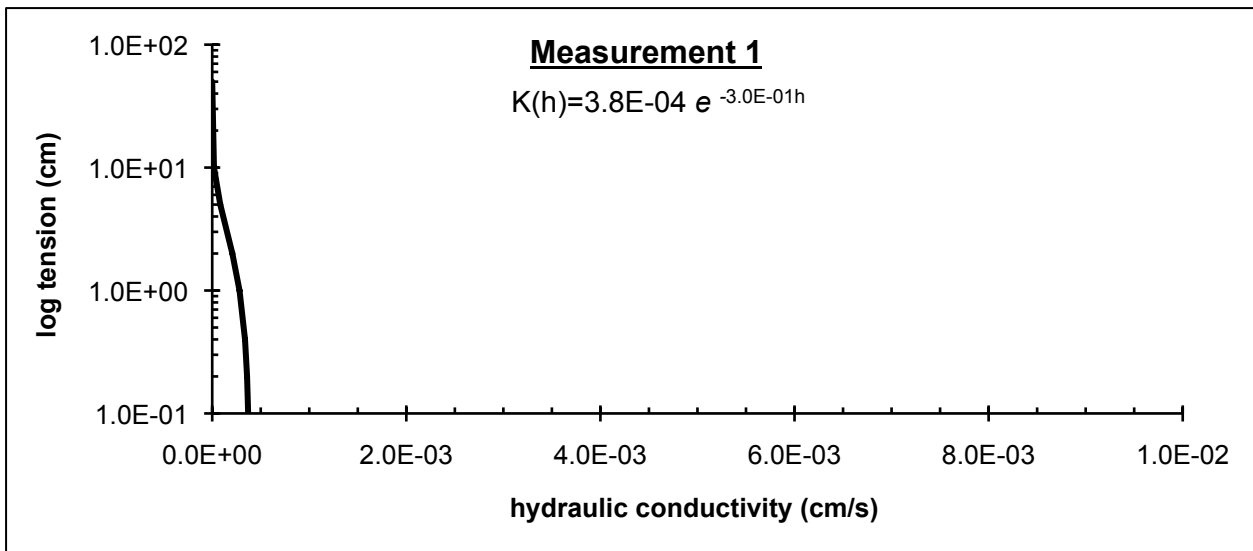
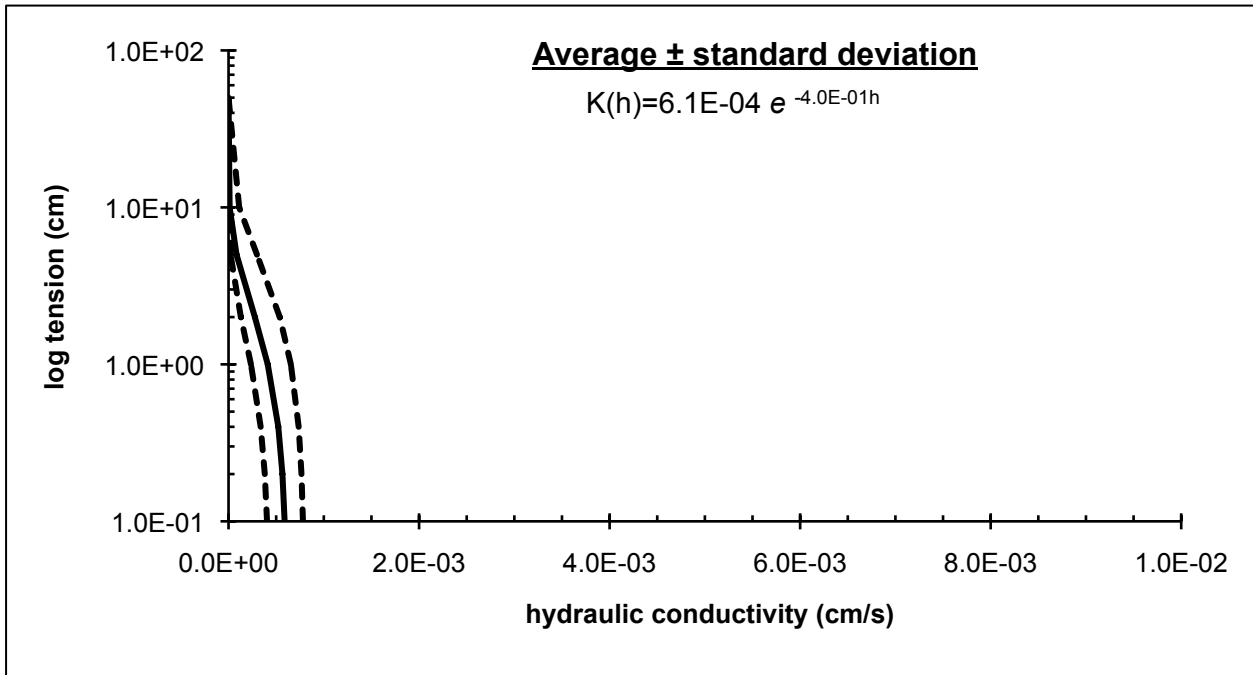

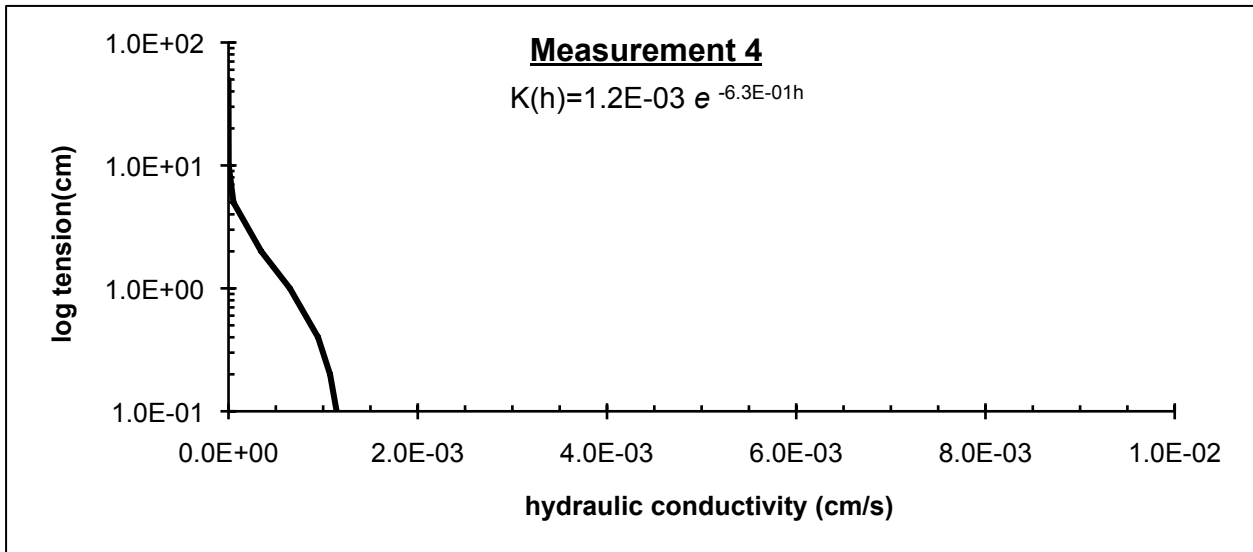
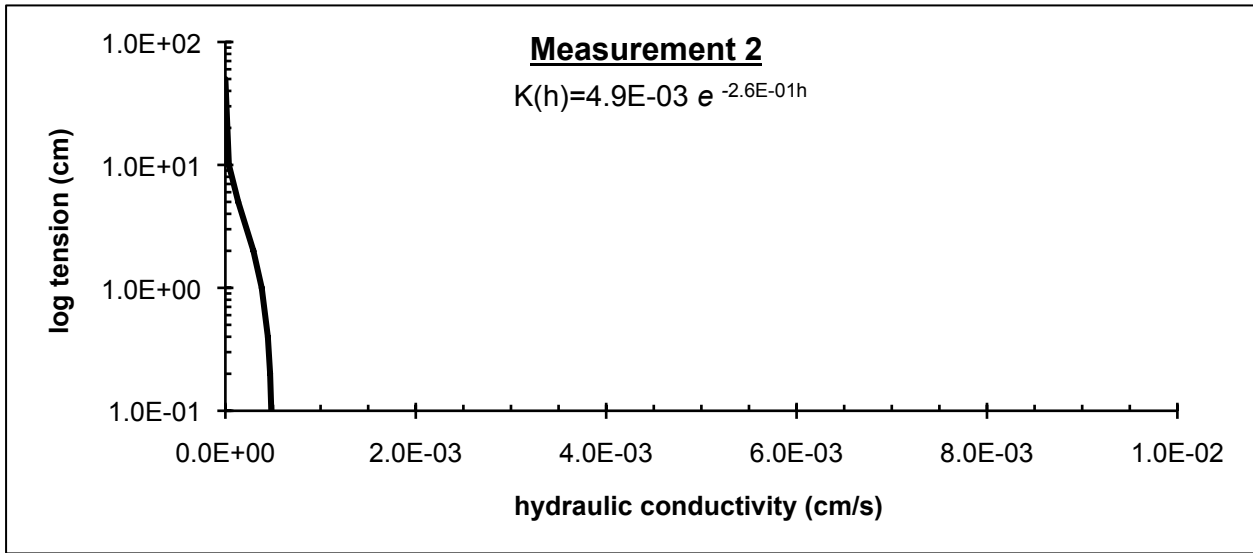

W19. Rutherford Rd at Ambassador Rd

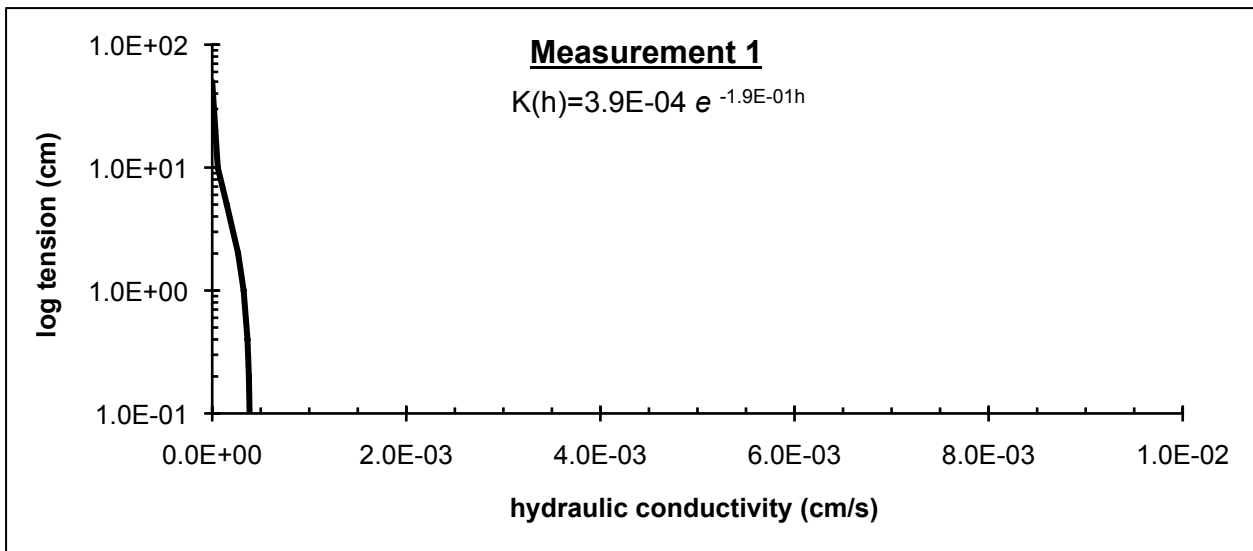
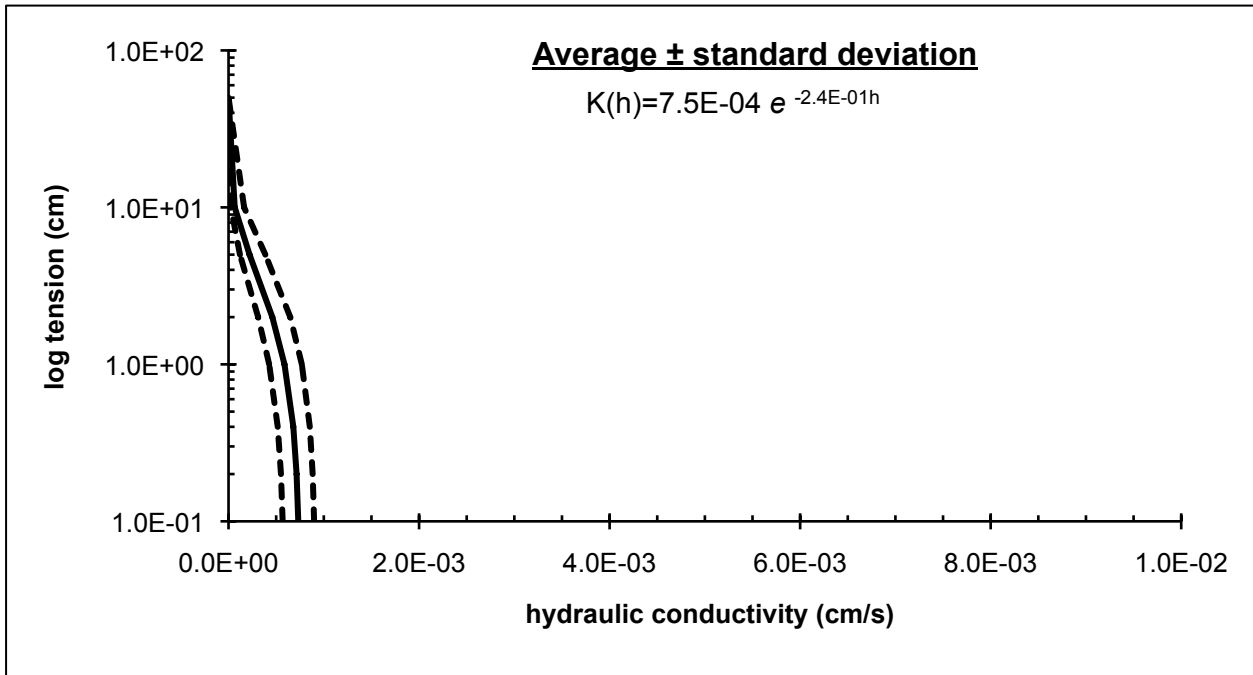

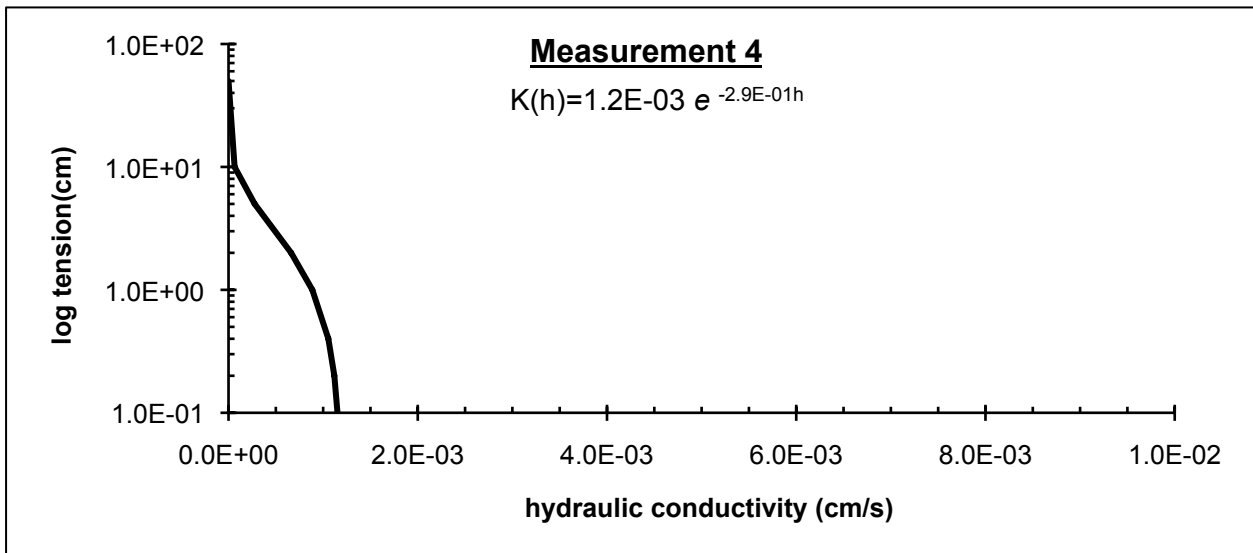
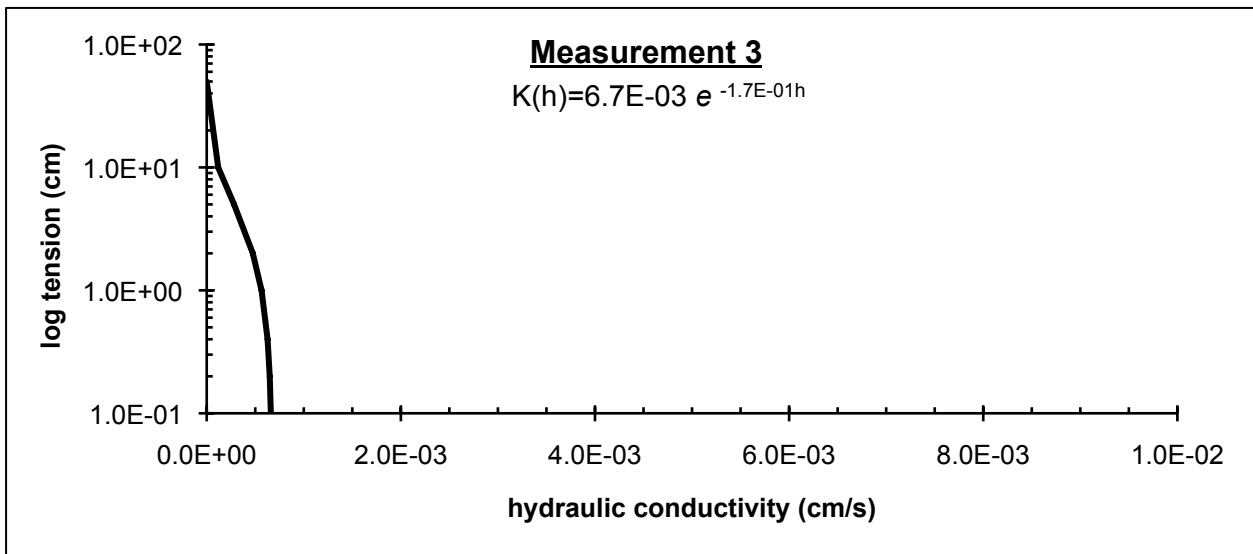
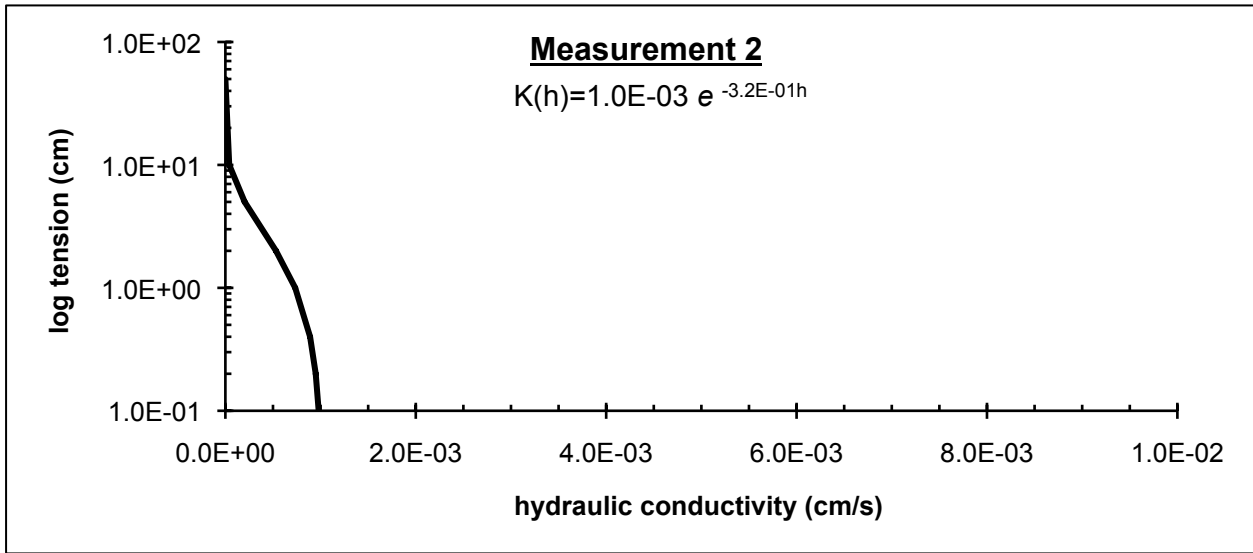

W21. Powder Mill Run Park

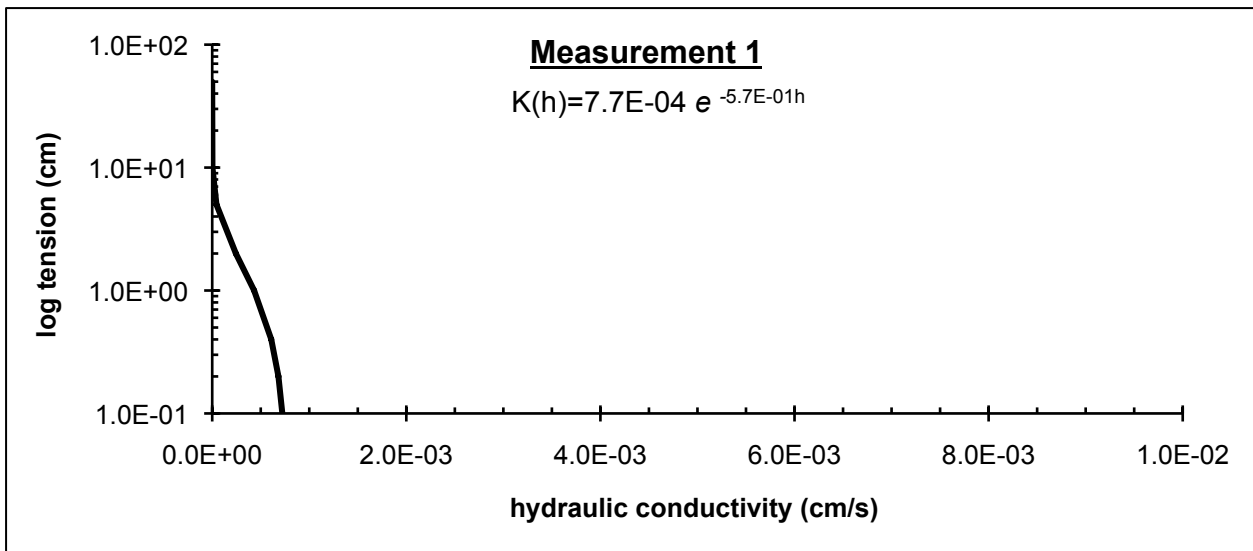
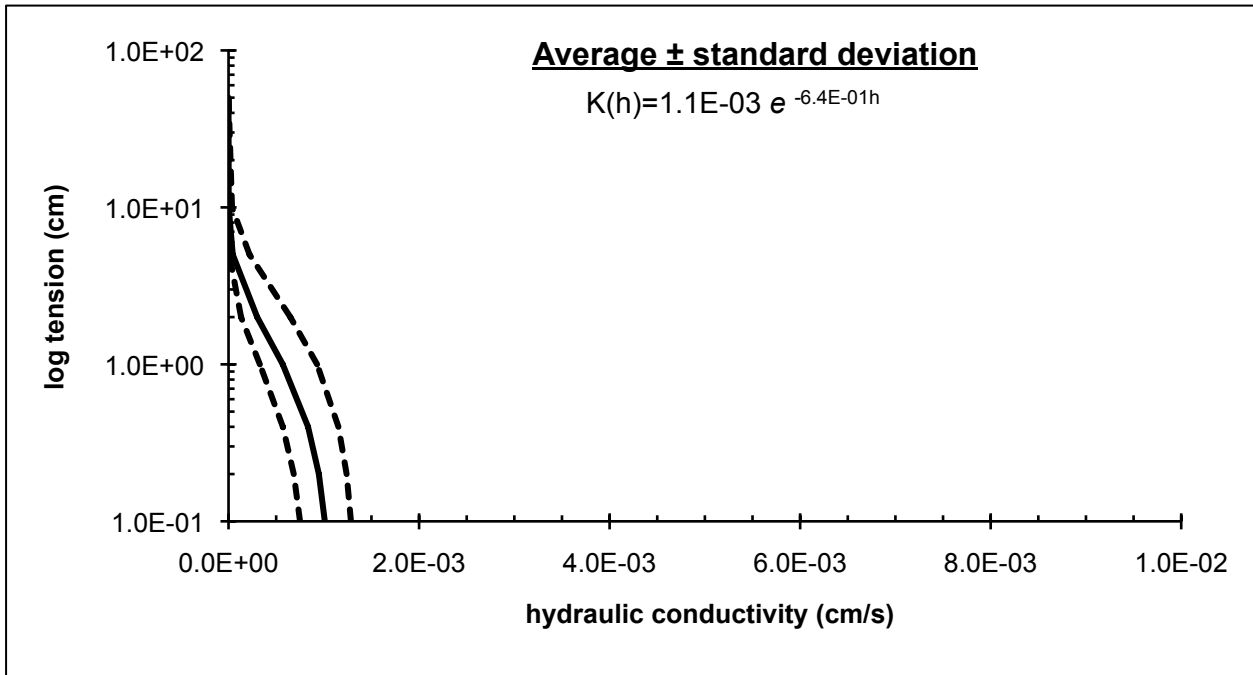

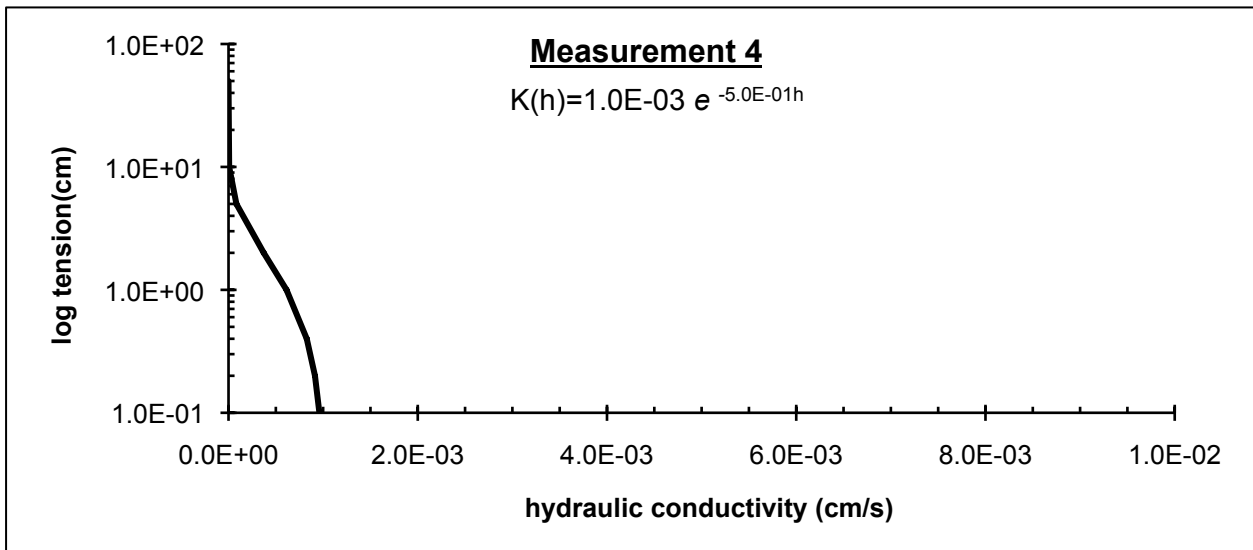
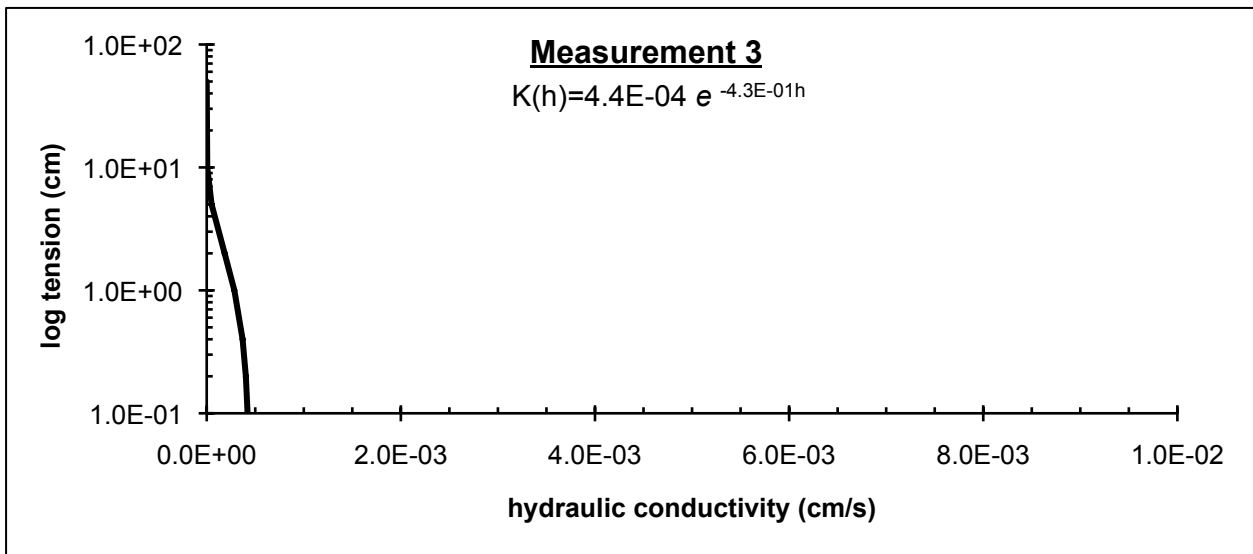
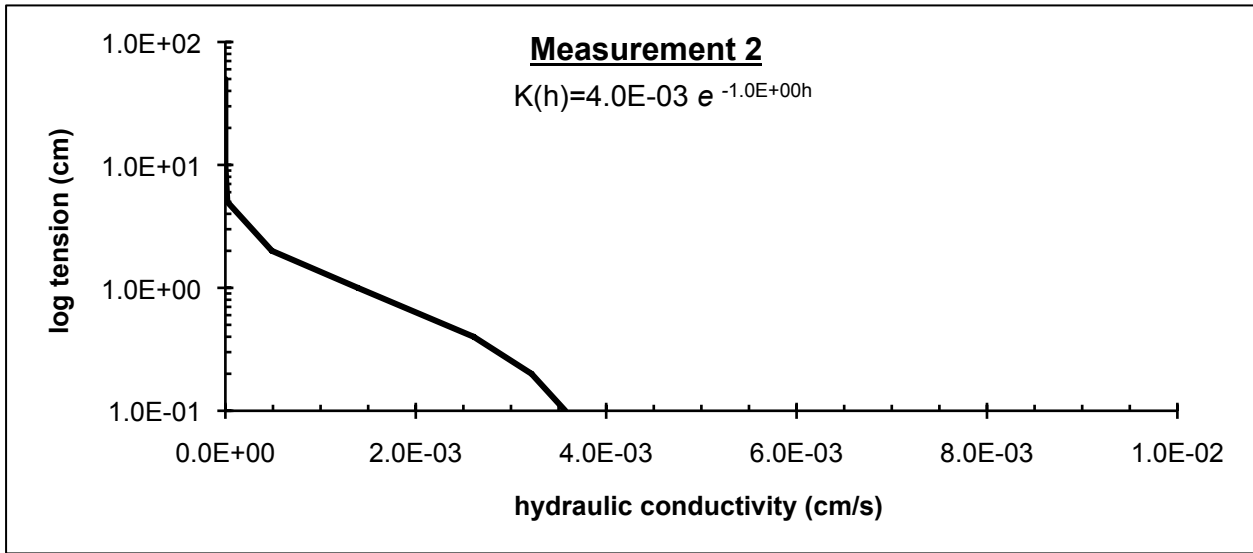

W22. Rockdale Park

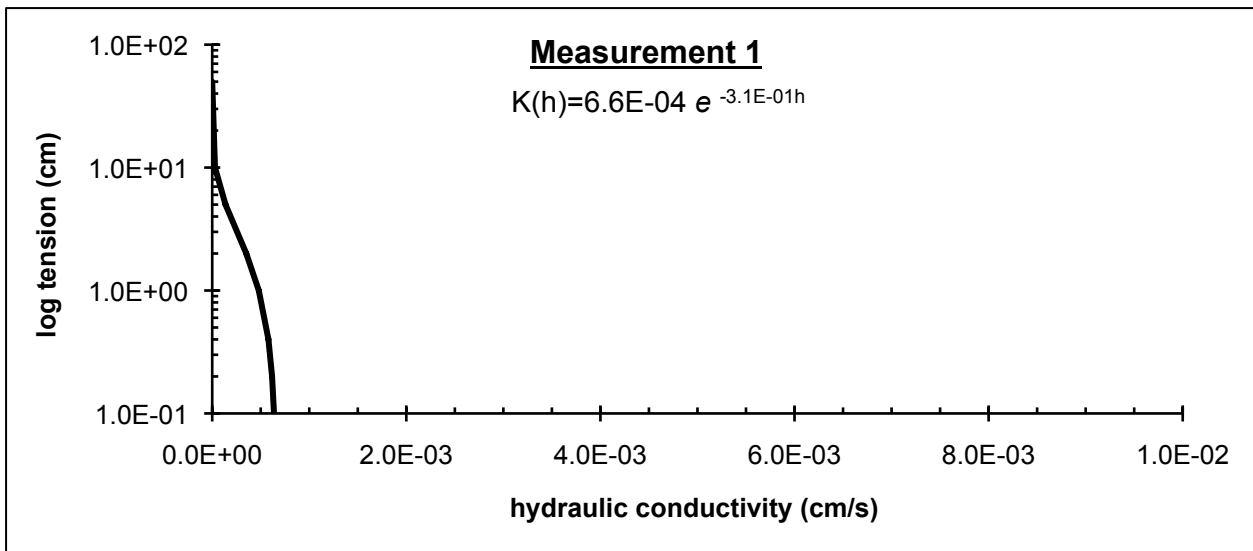
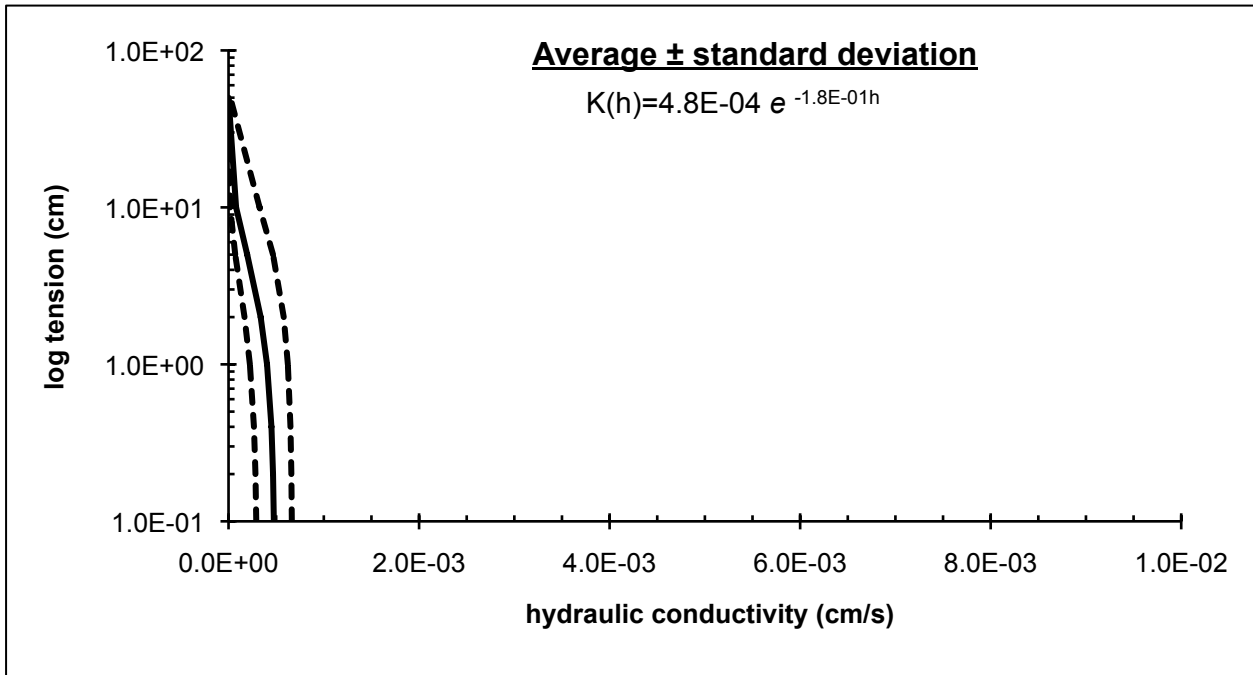

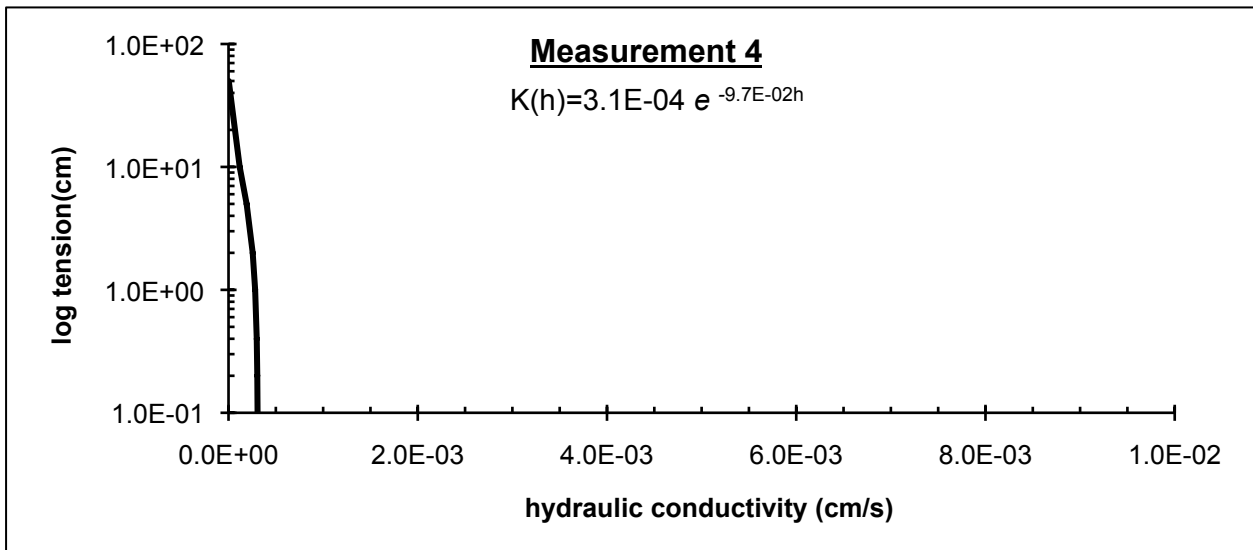
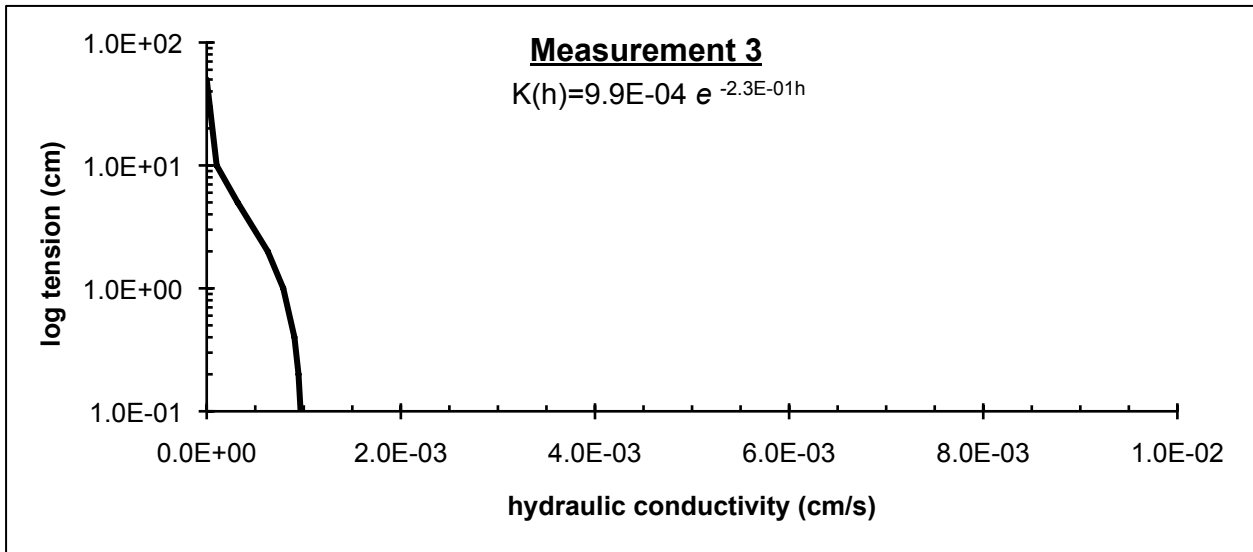
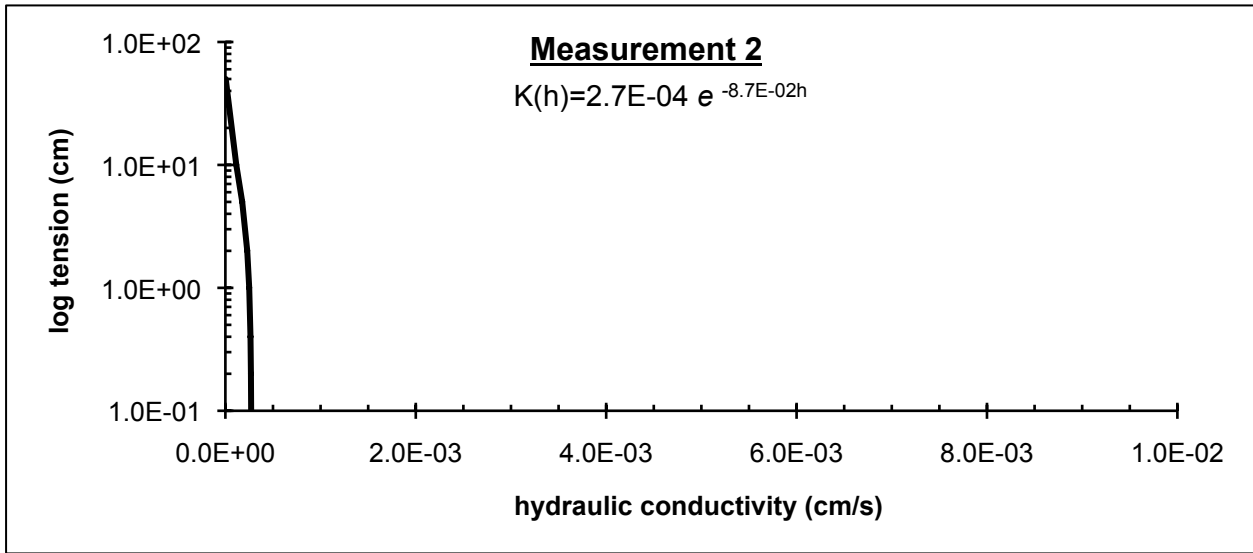

W25. Old Court Middle School

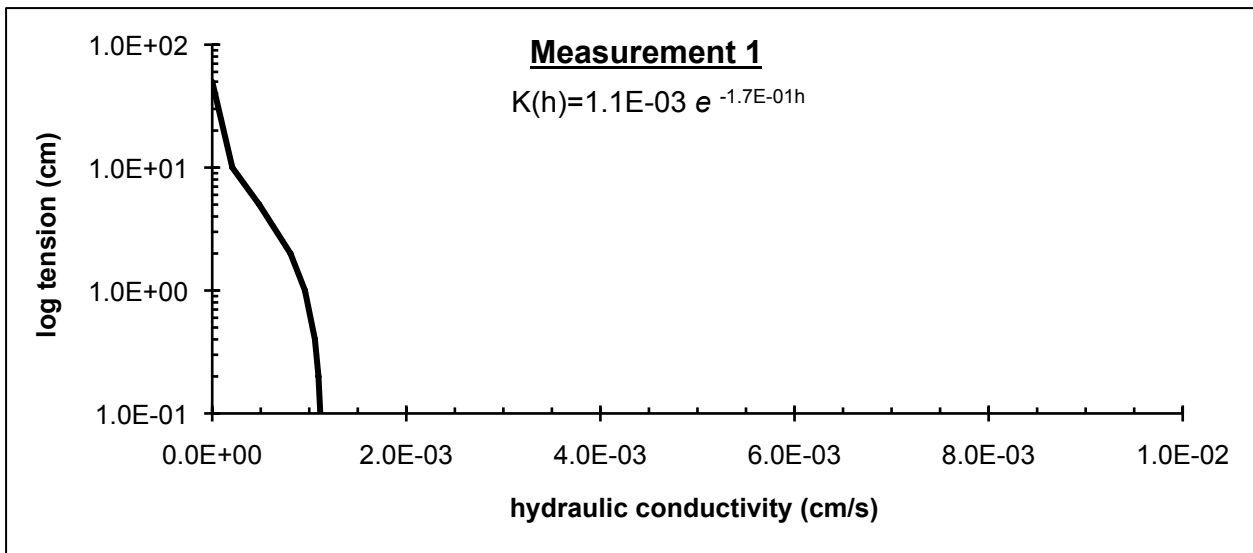
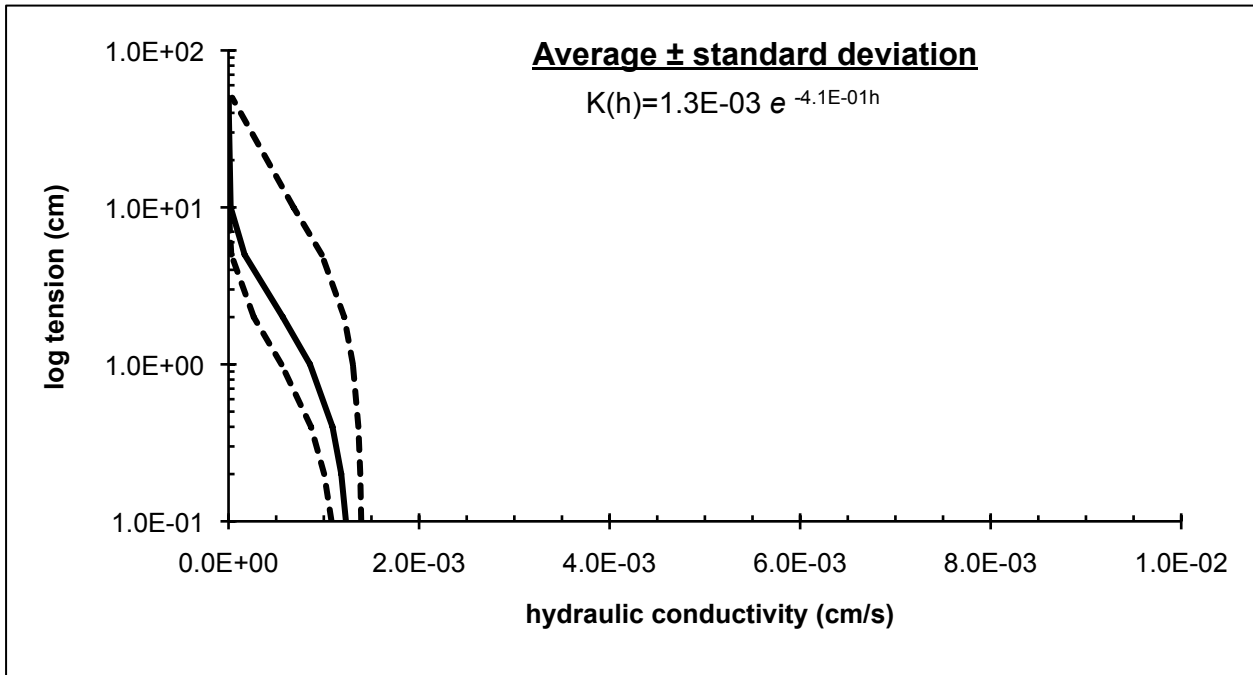

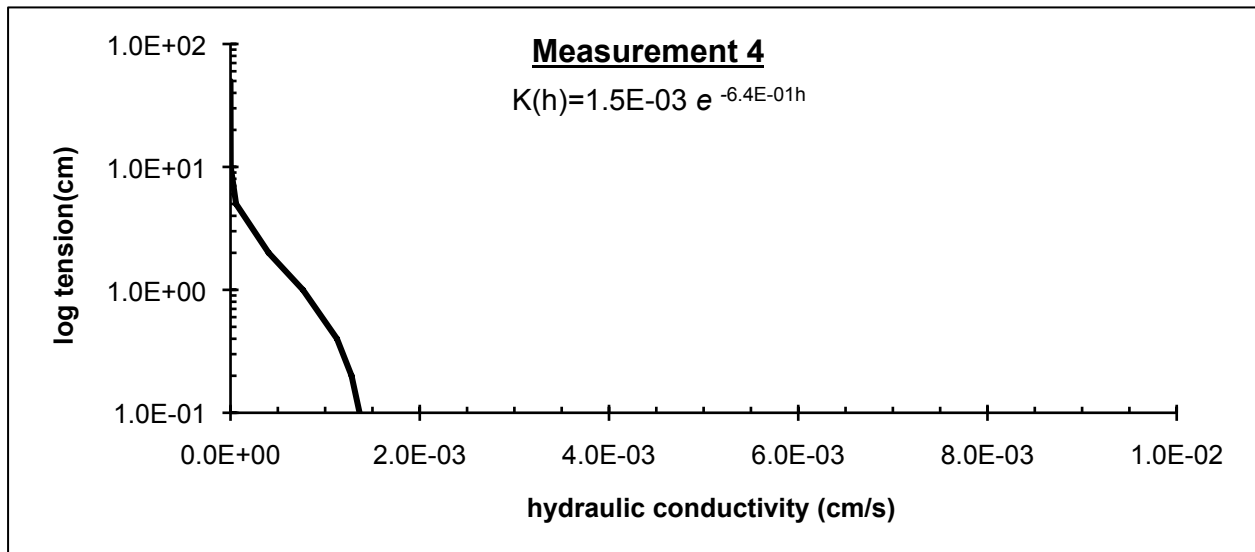

W26. Old Court Rd at Harden Rd

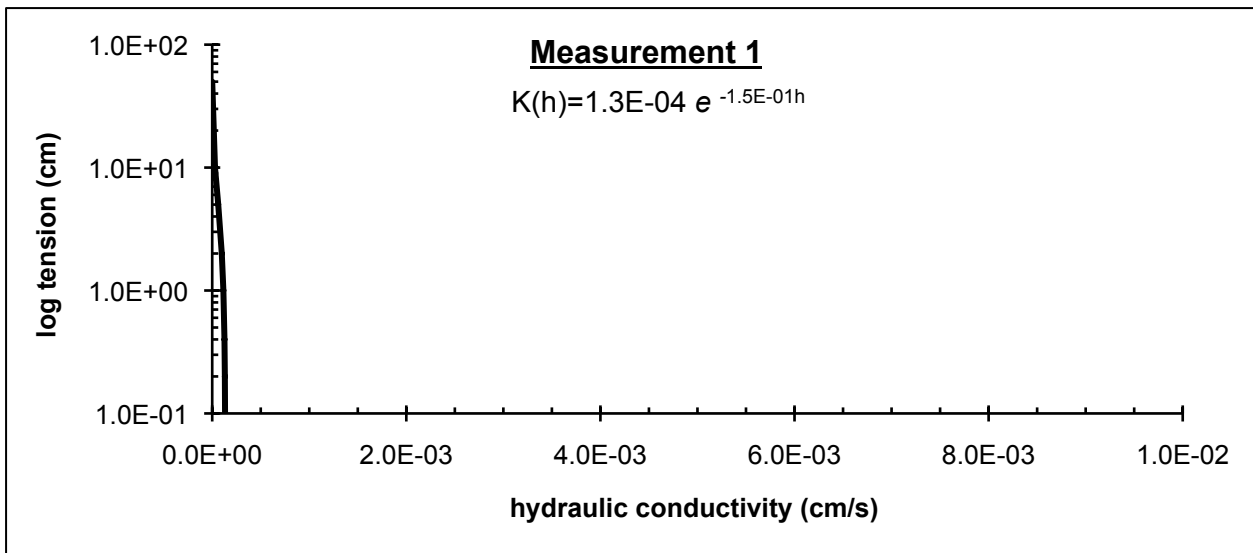
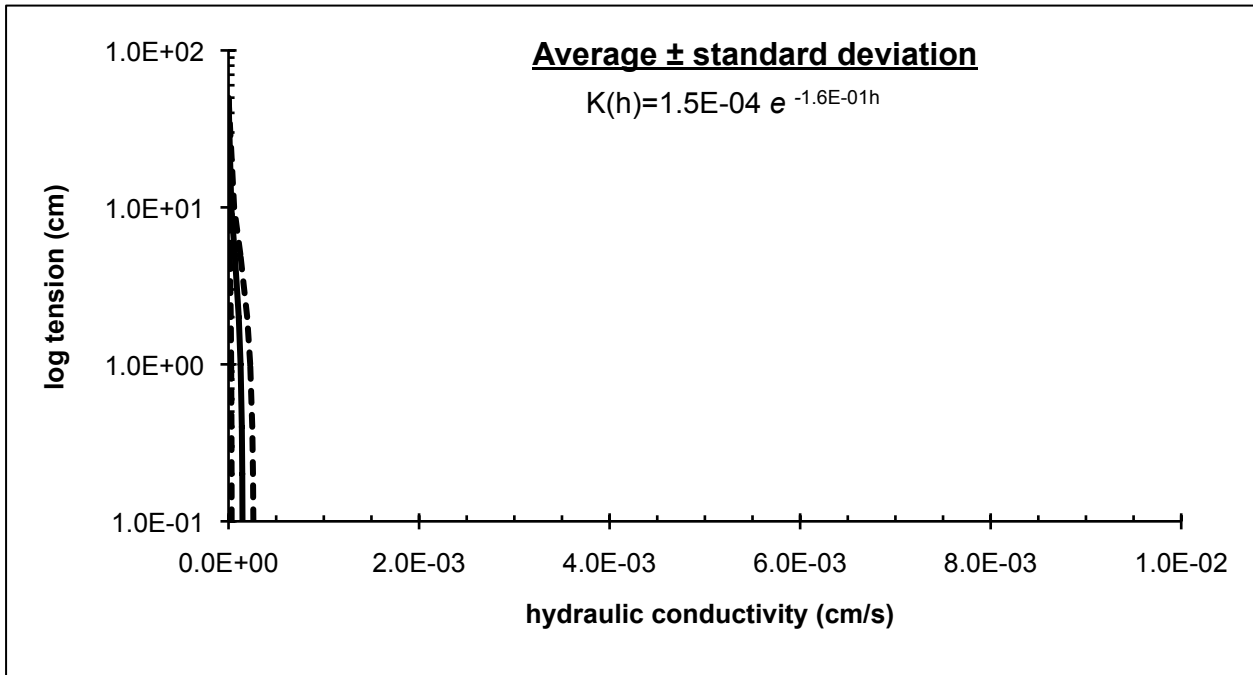

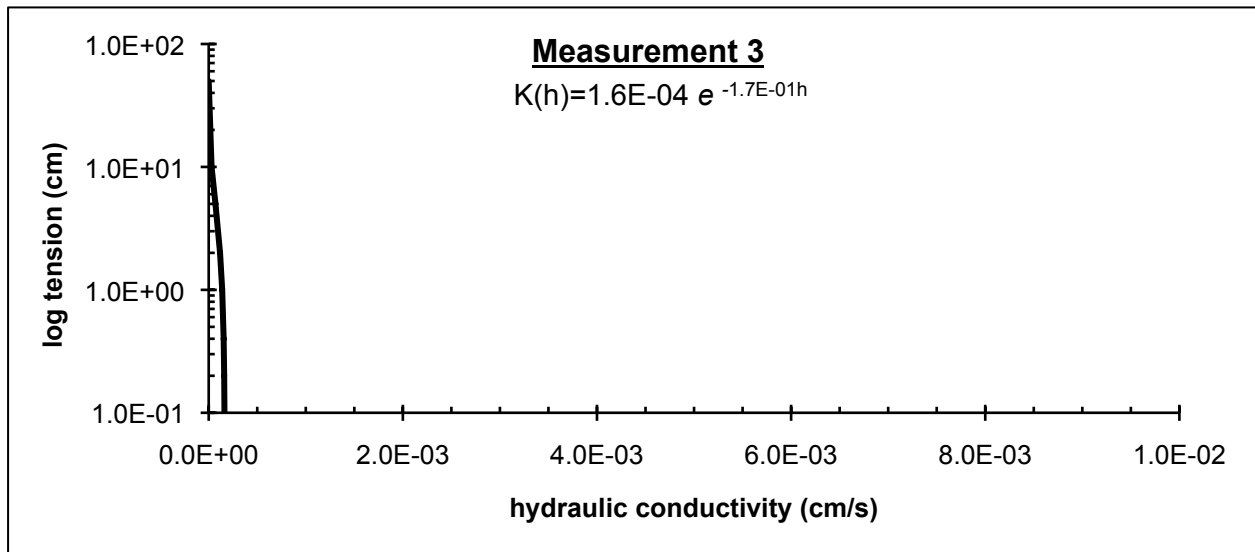

W27. McDonogh Rd at Brentford Rd

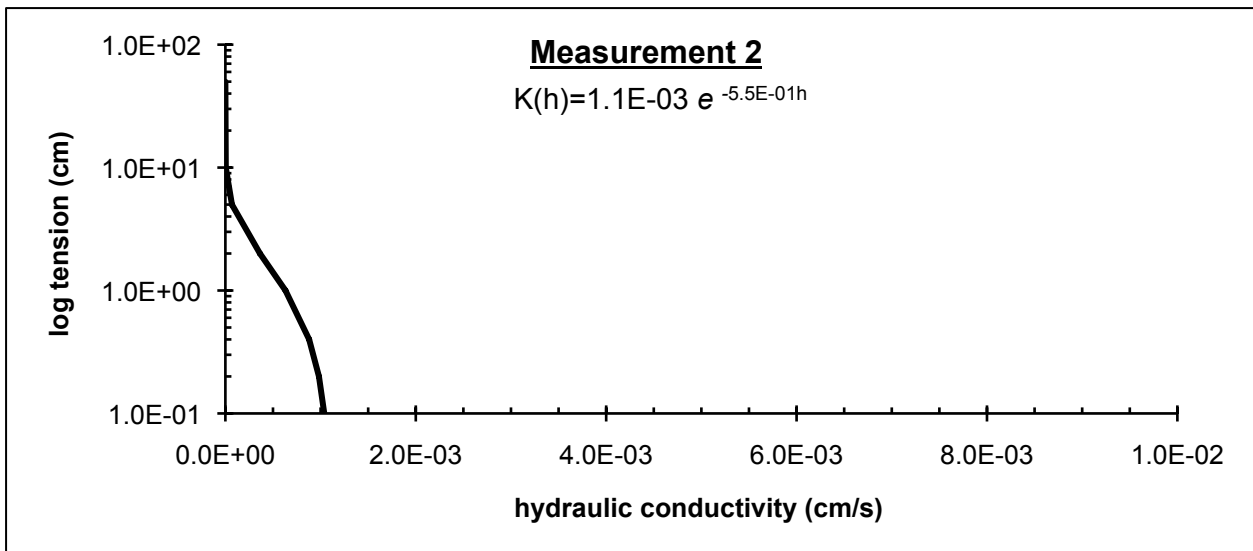
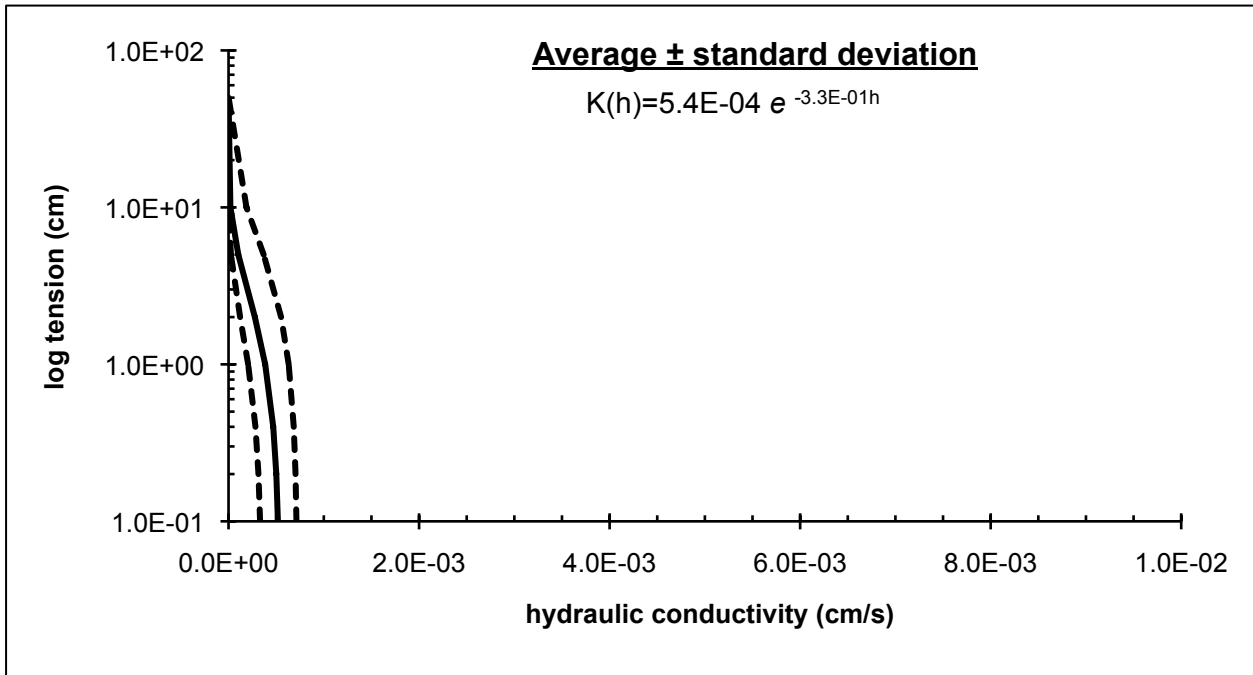

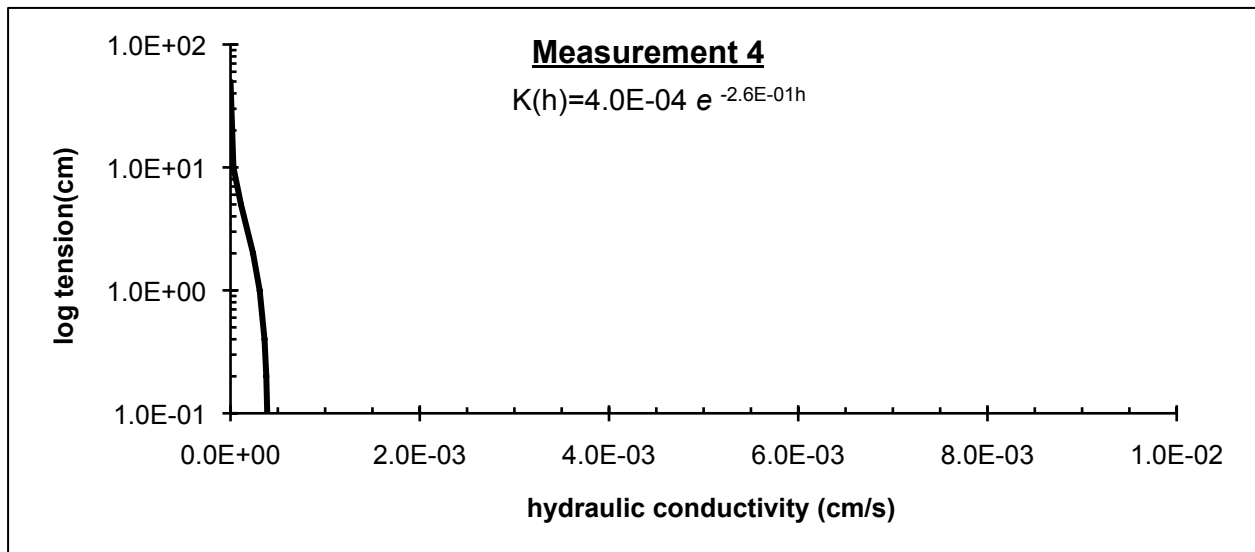
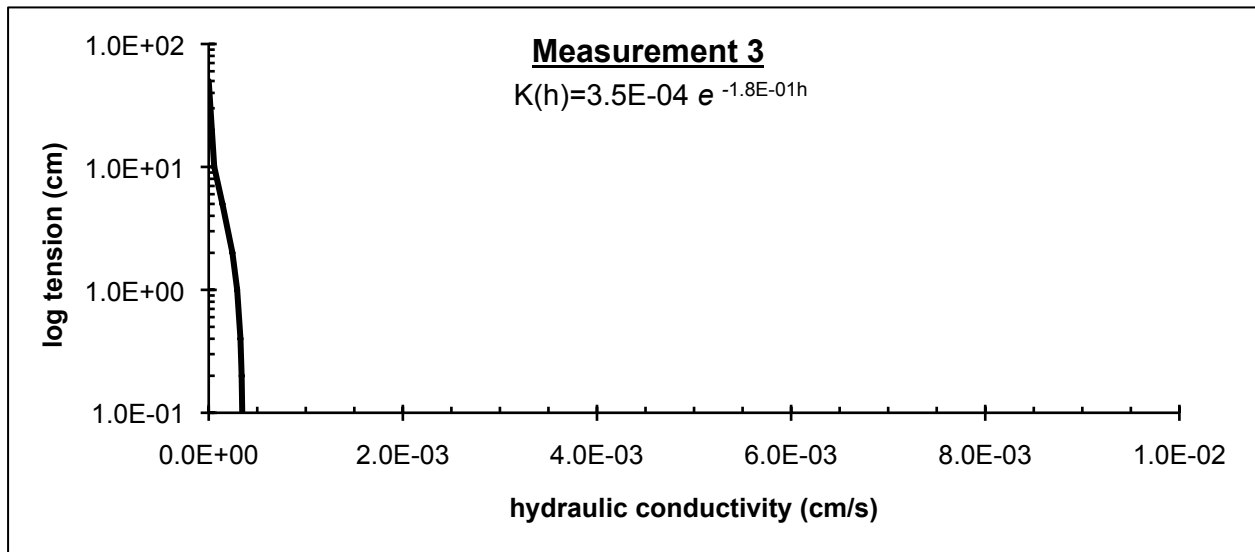

W28. Spyce Mill Rd

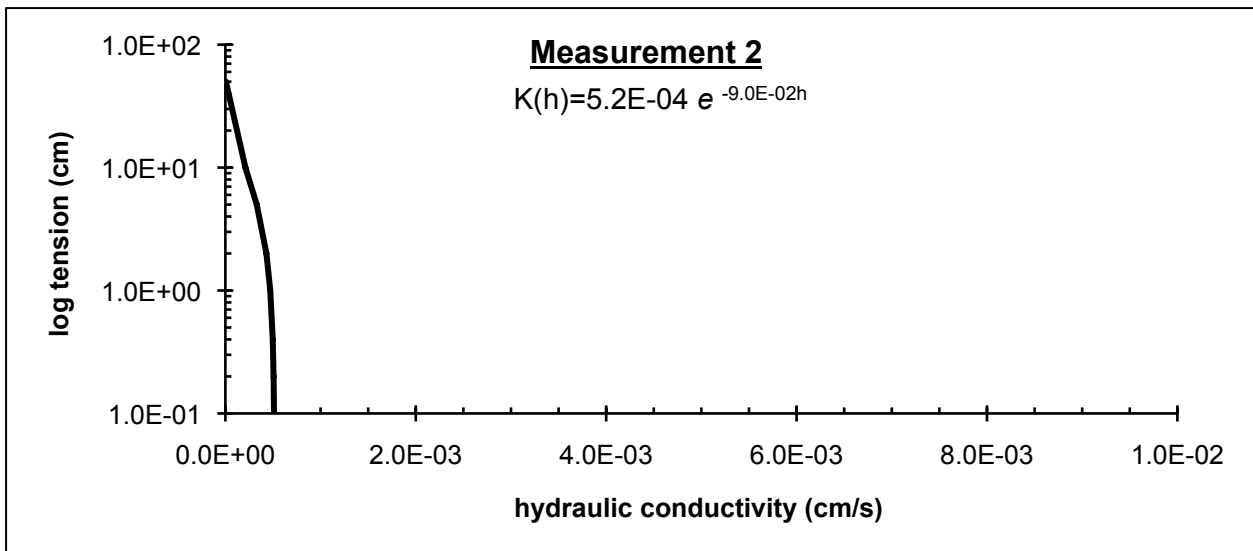
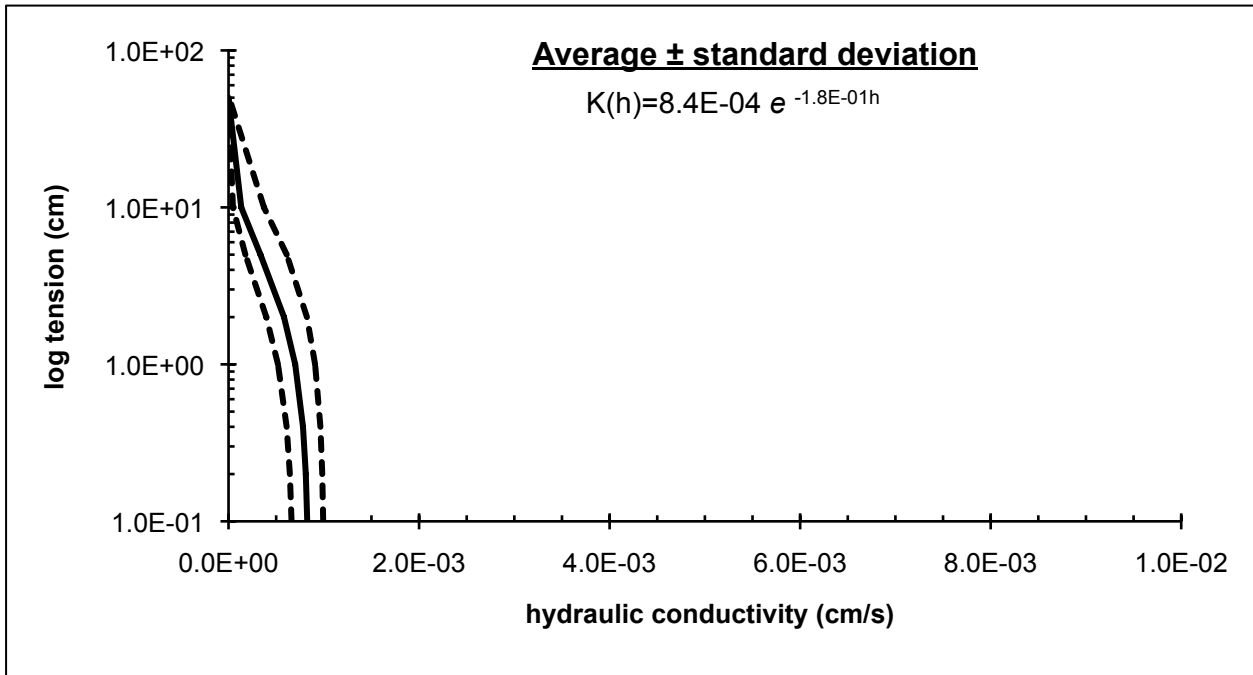

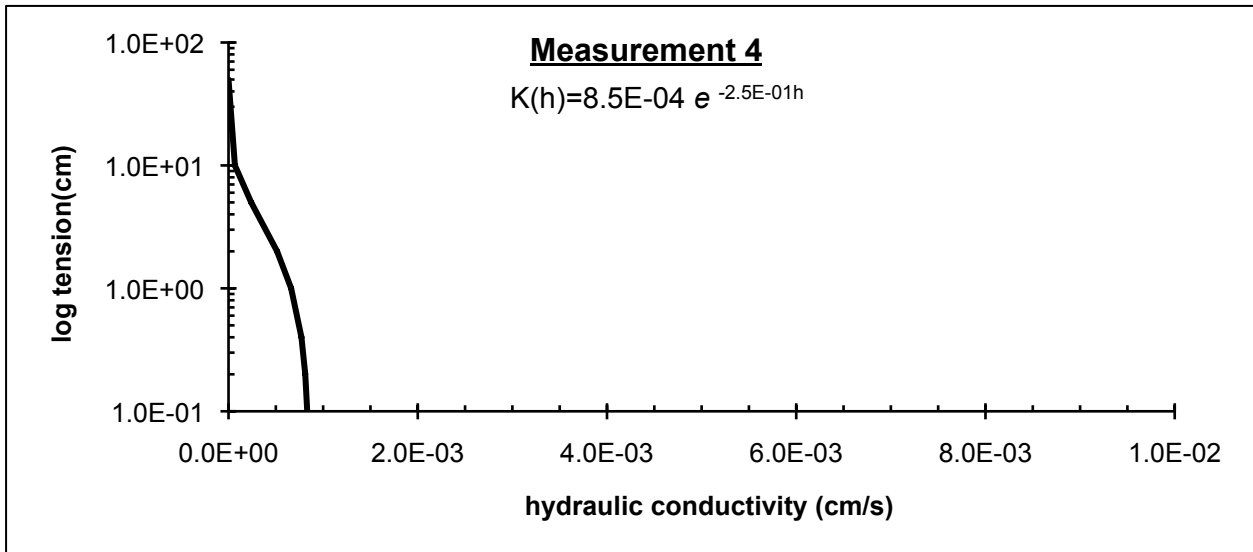
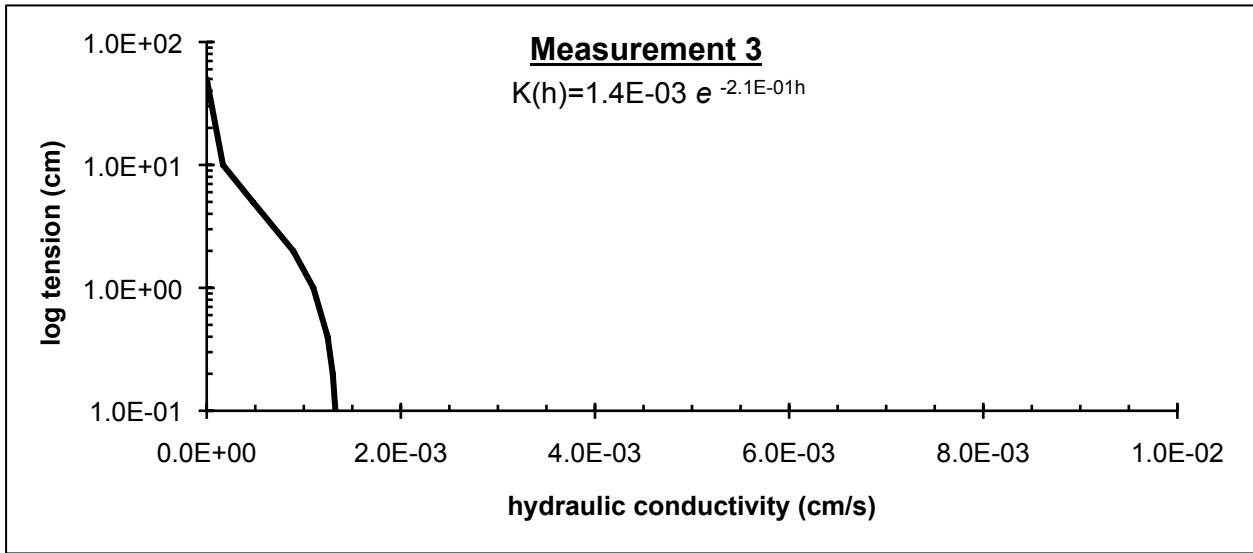

W30. Tulsemere Rd at Pikeswood Rd

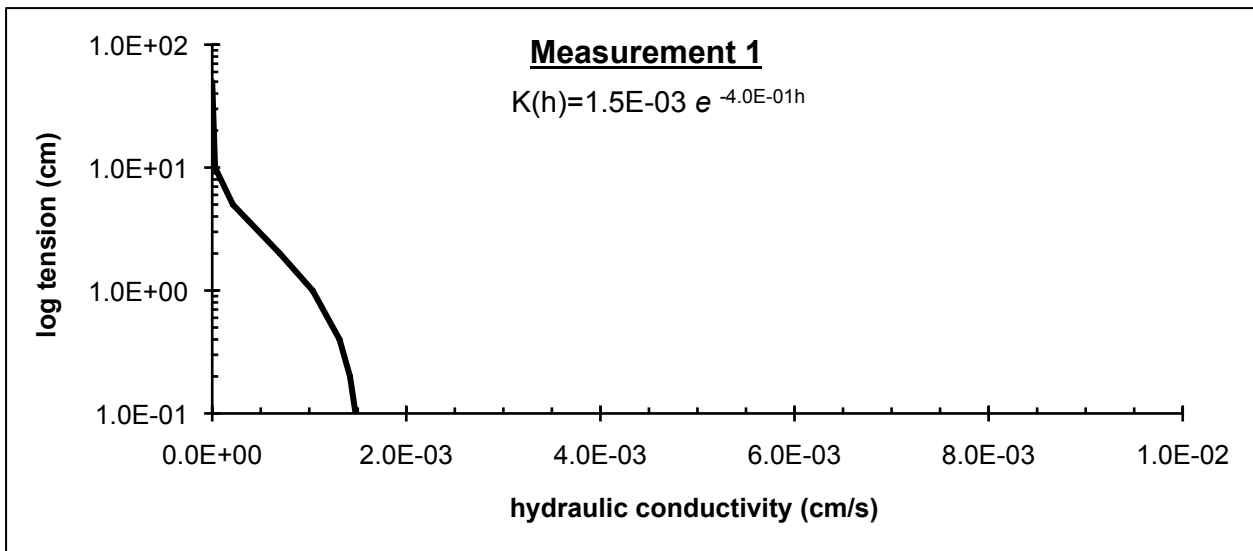
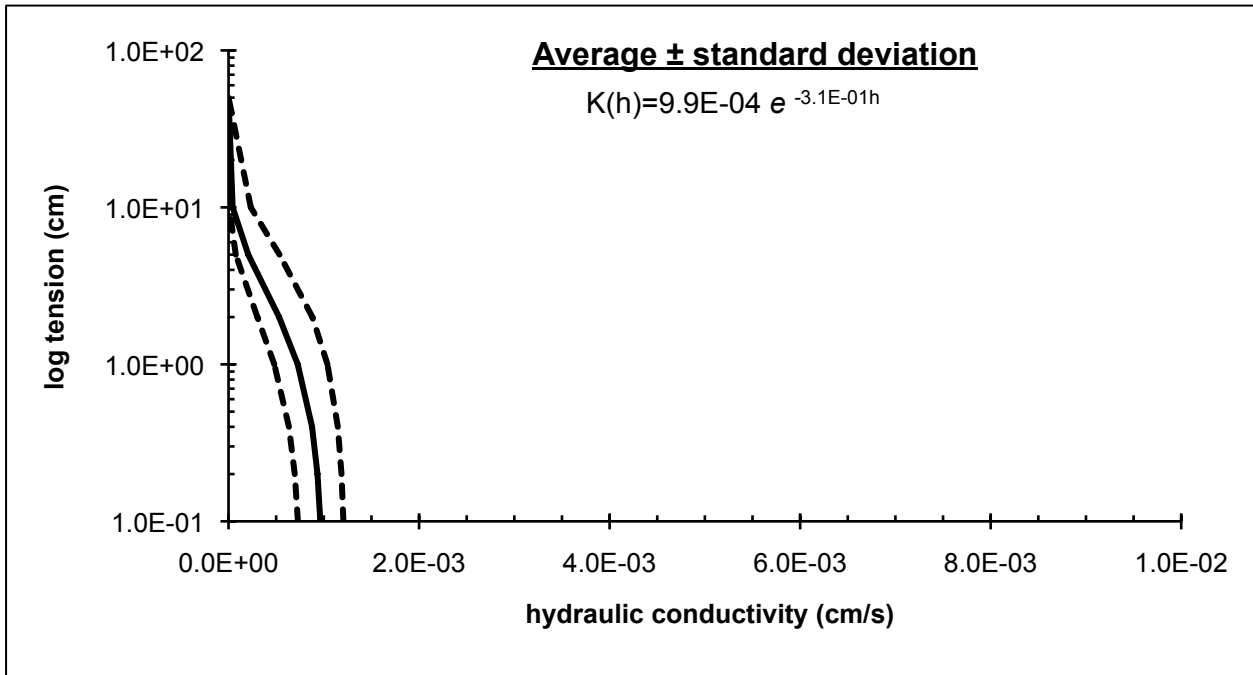

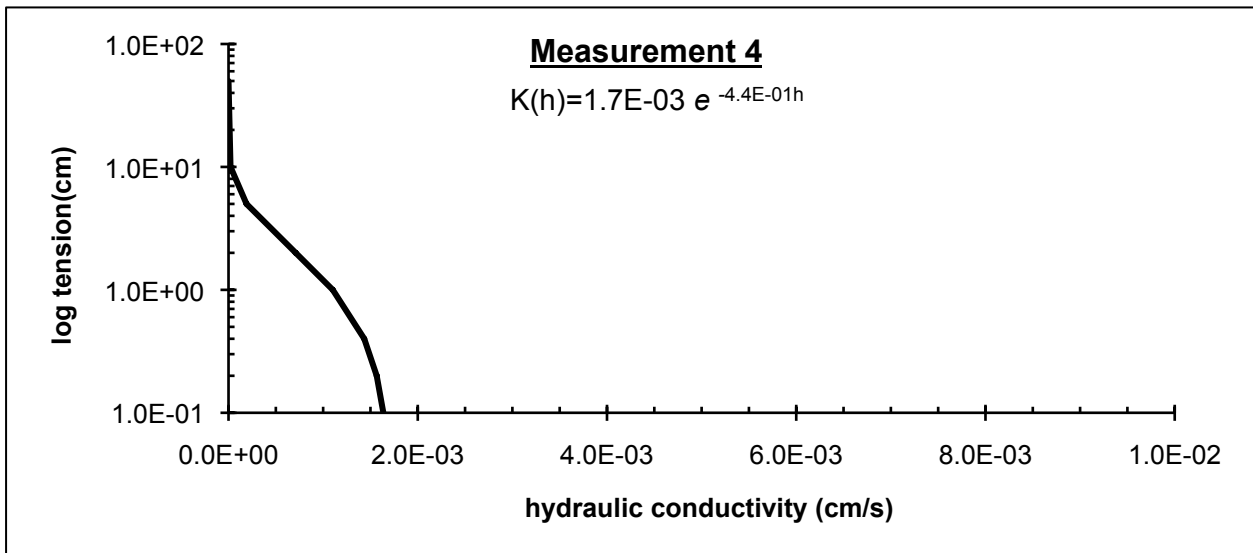
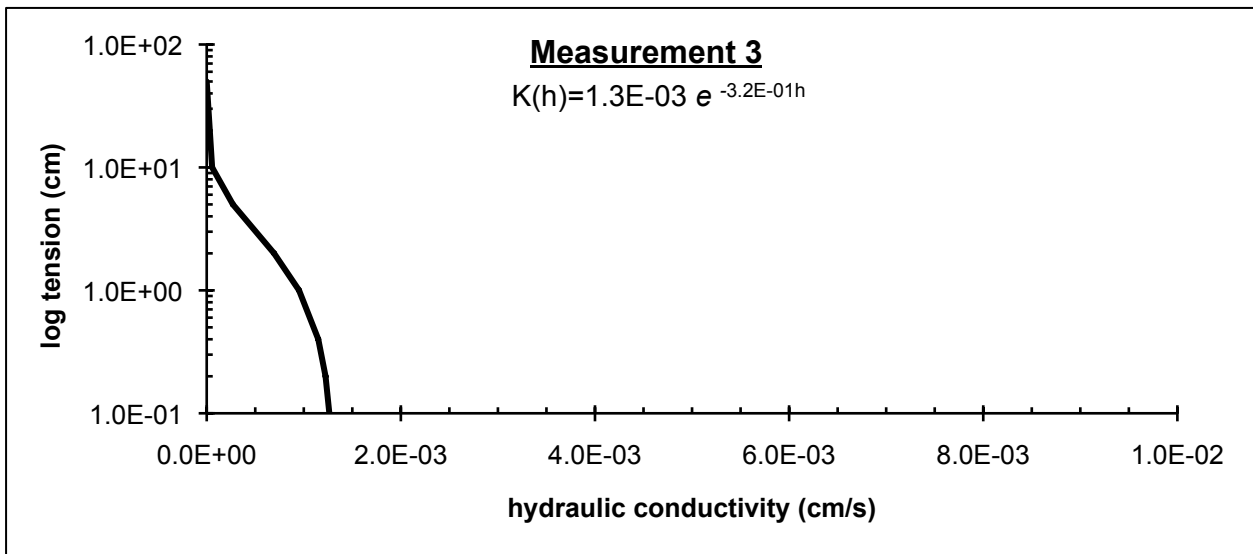
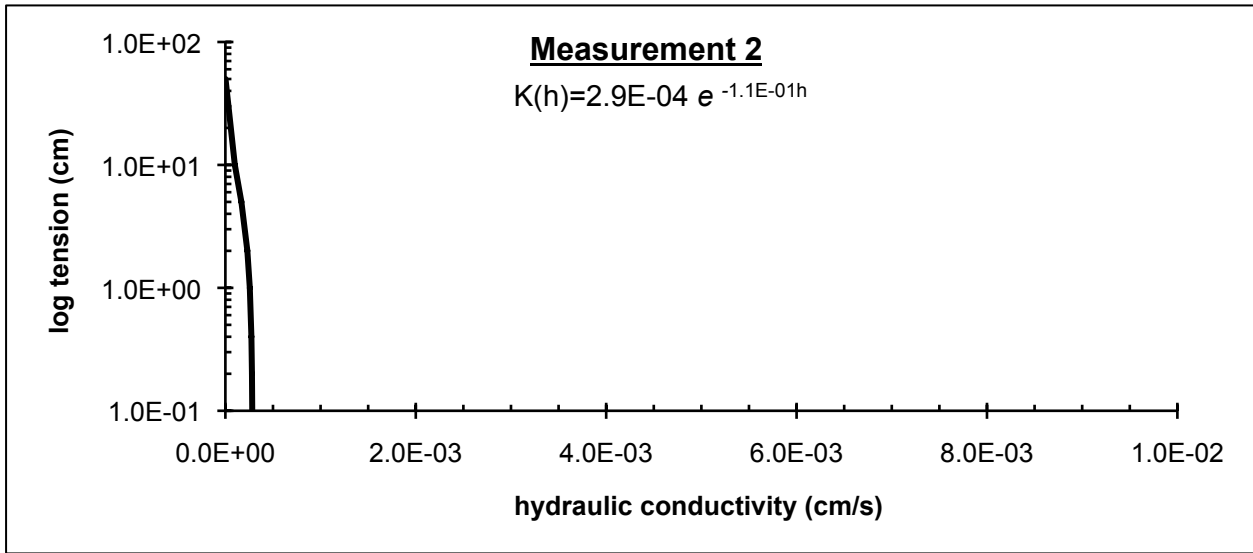

W31. Wynfield Rd at Devlon Ct

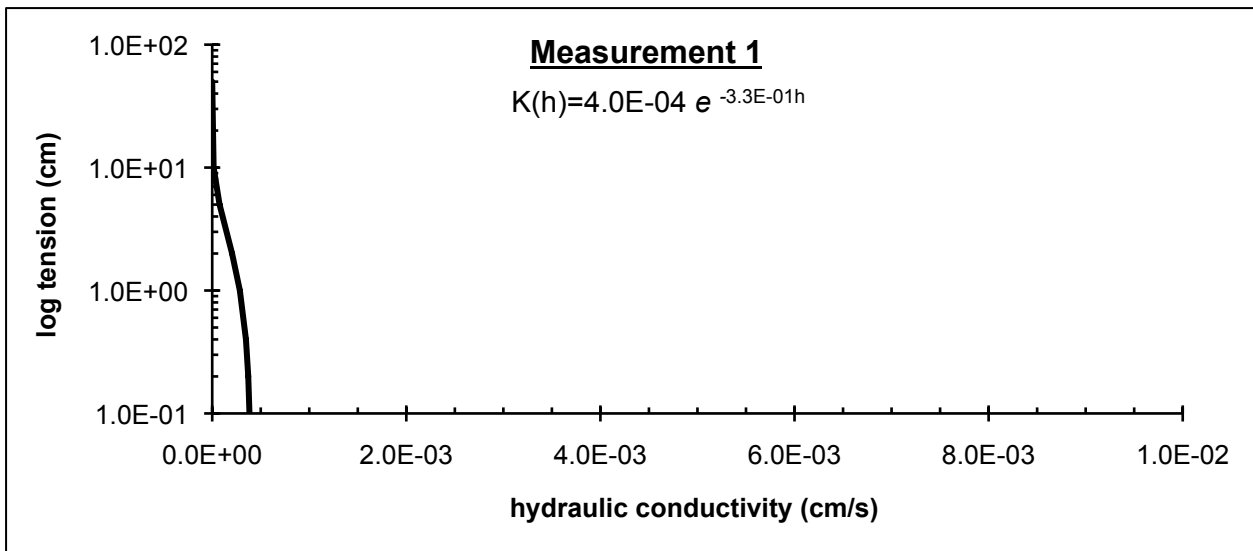
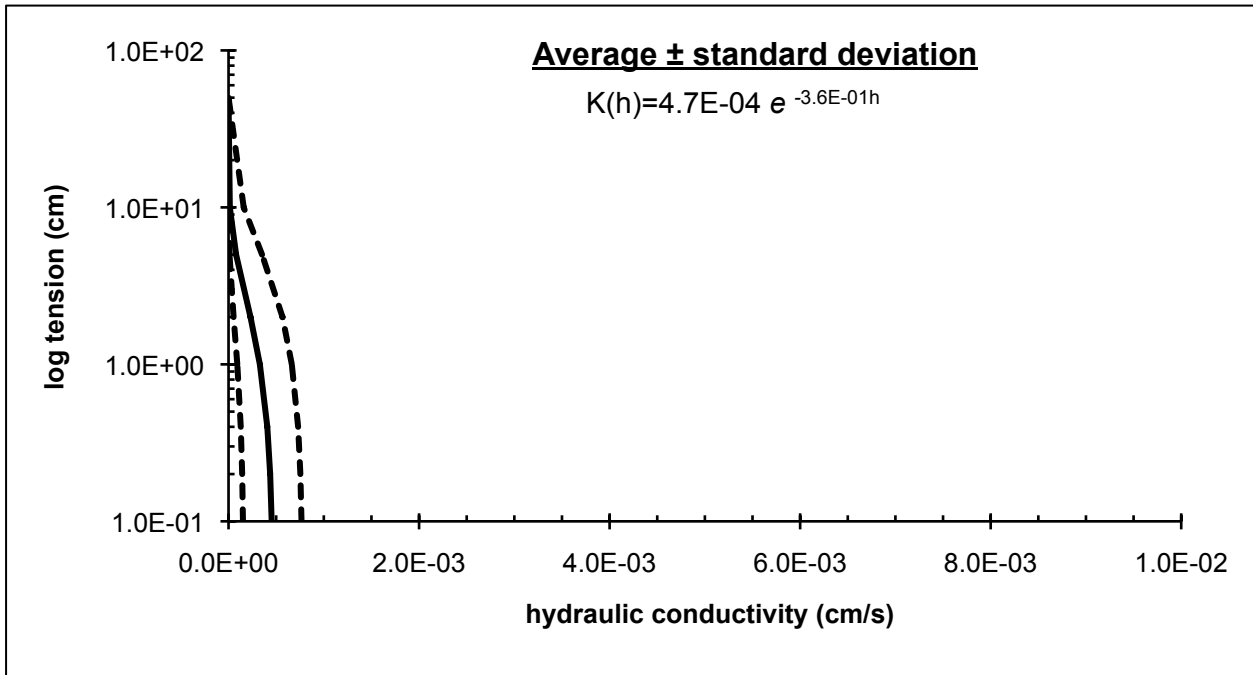

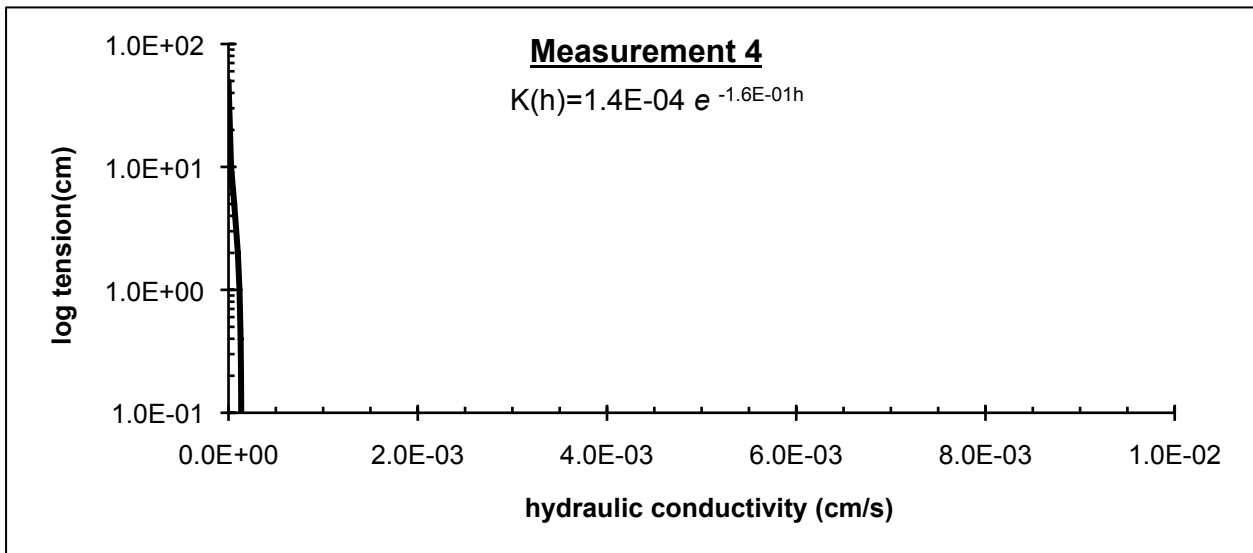
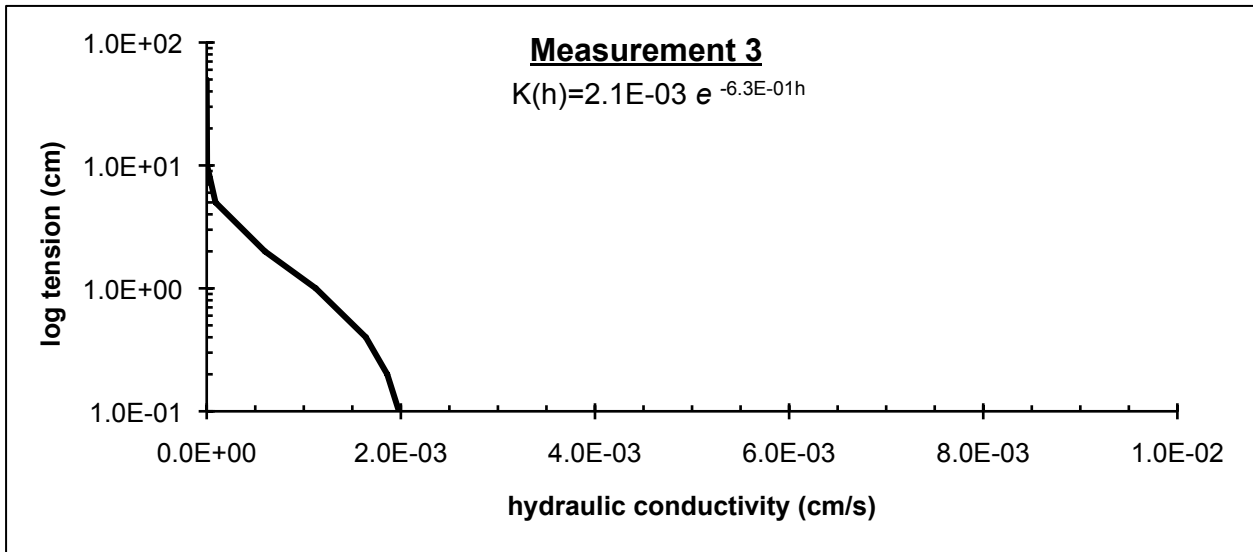
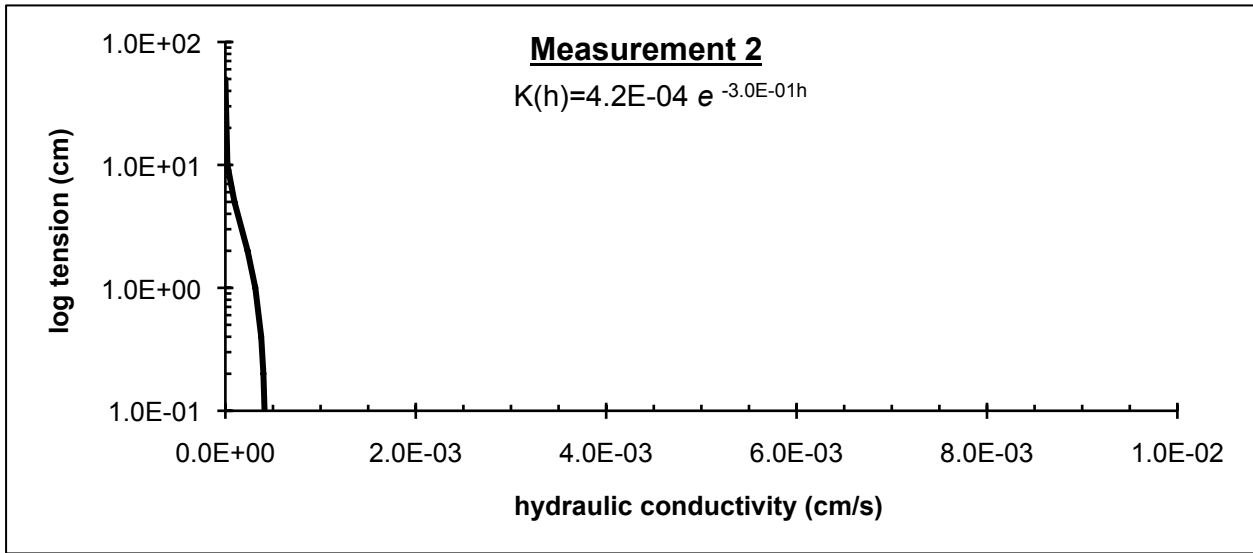

W33. New Town High School

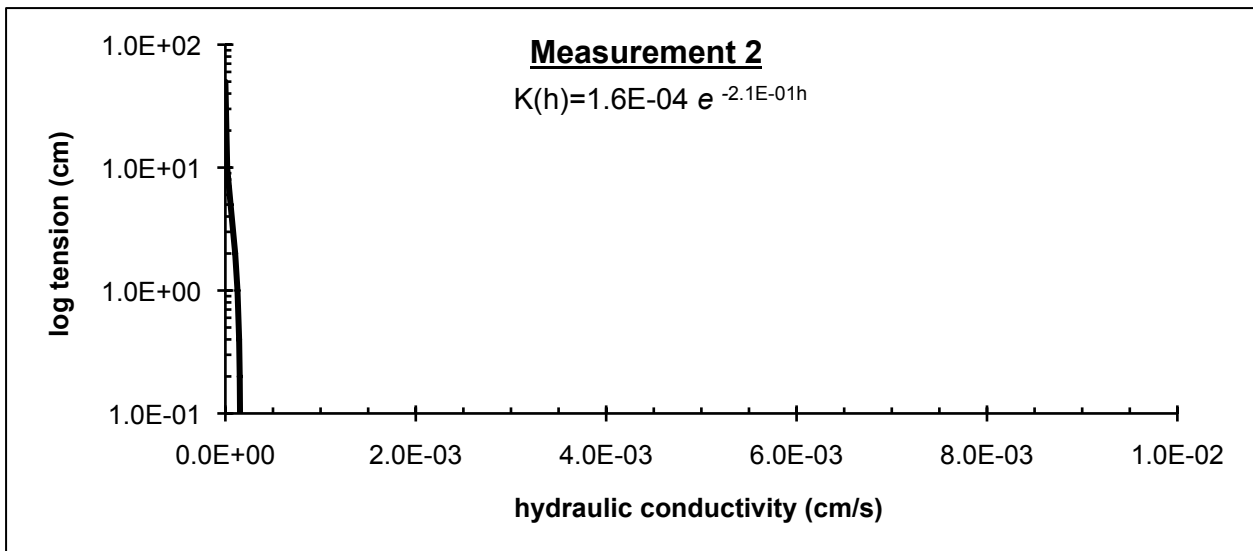
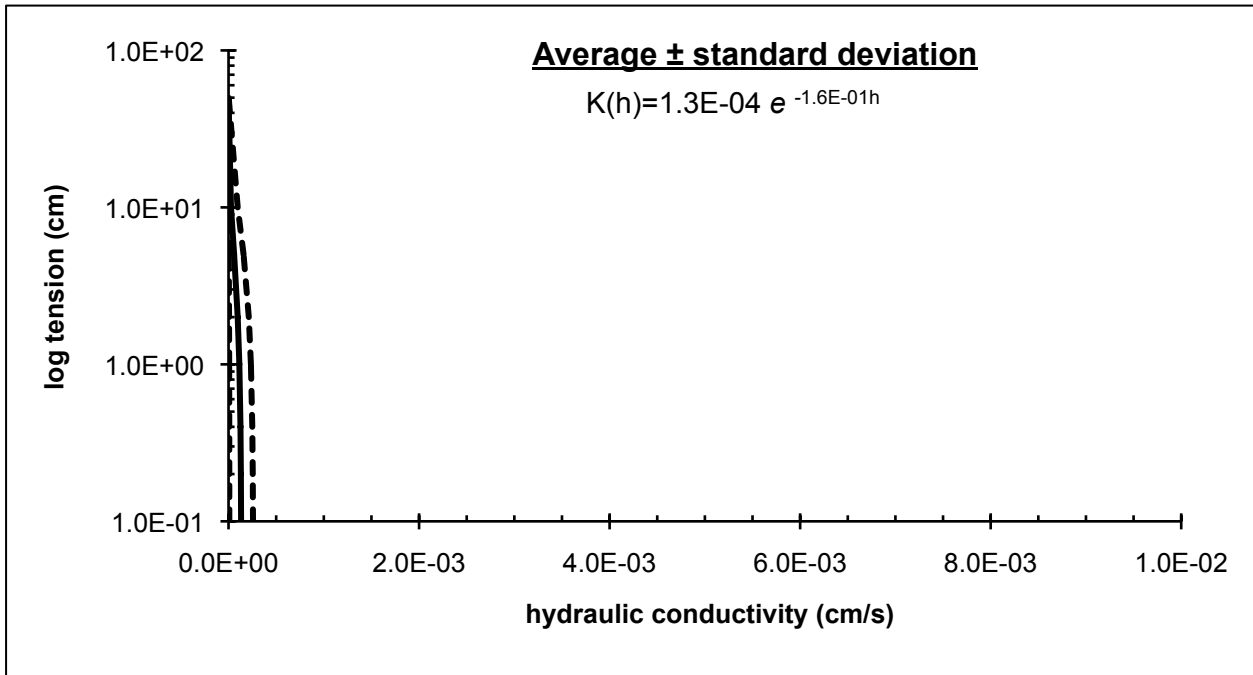

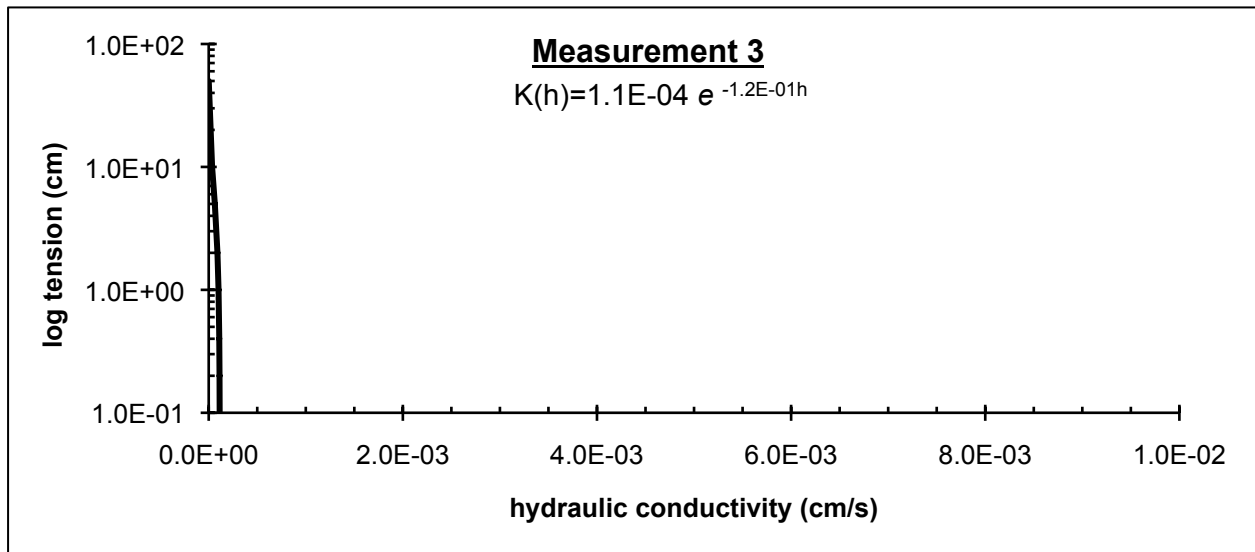

W34. Dolfield Rd at Ritters Ln

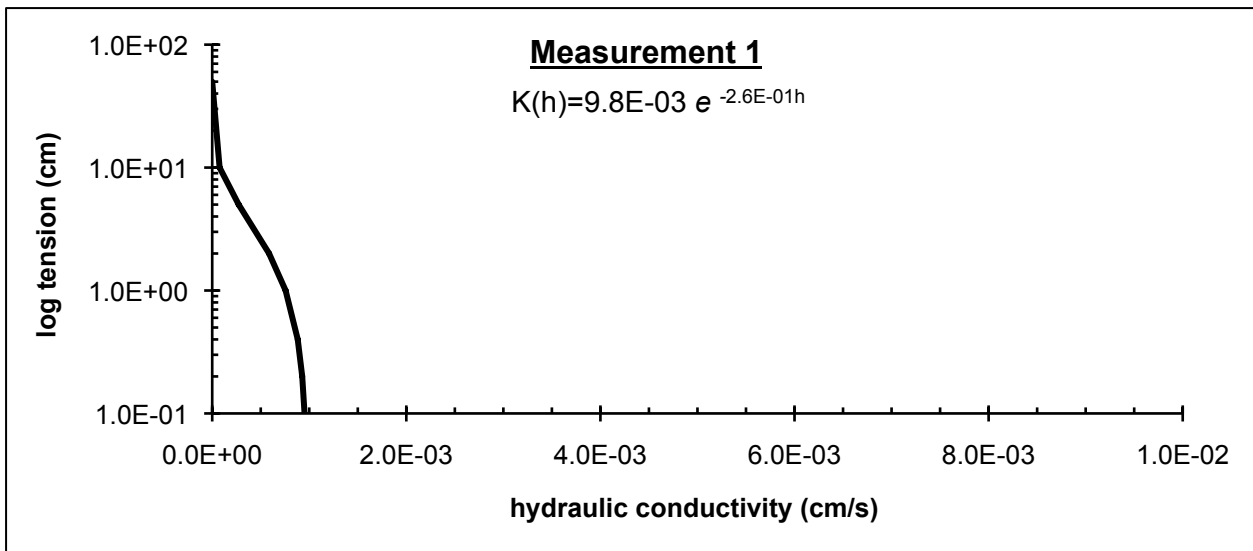
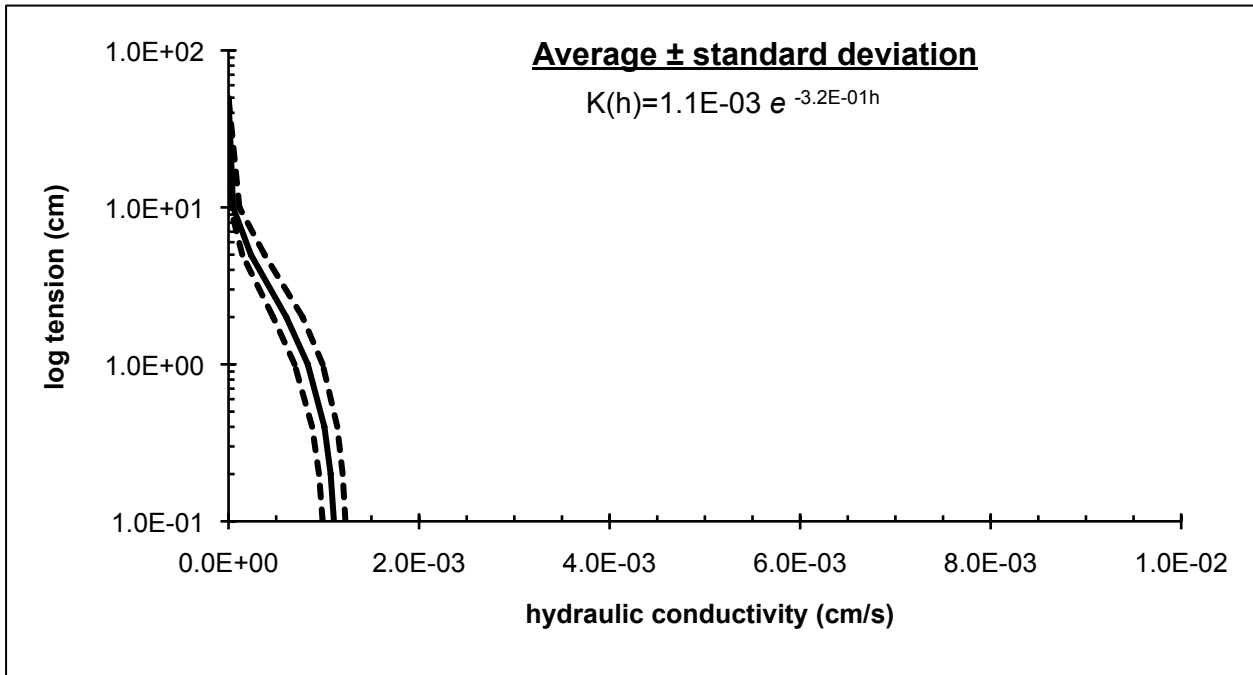

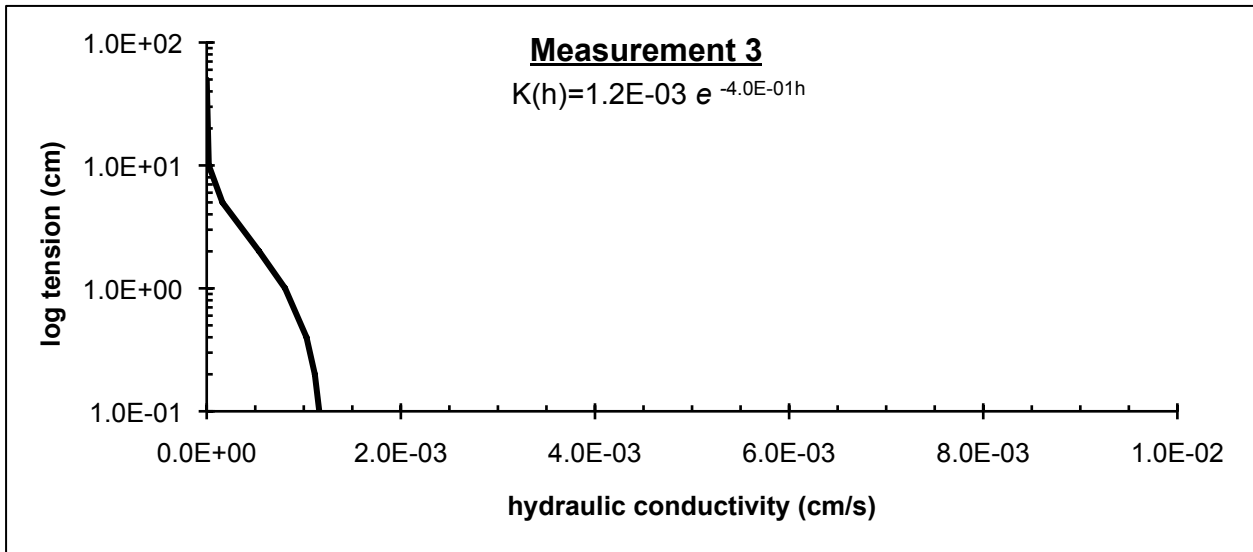
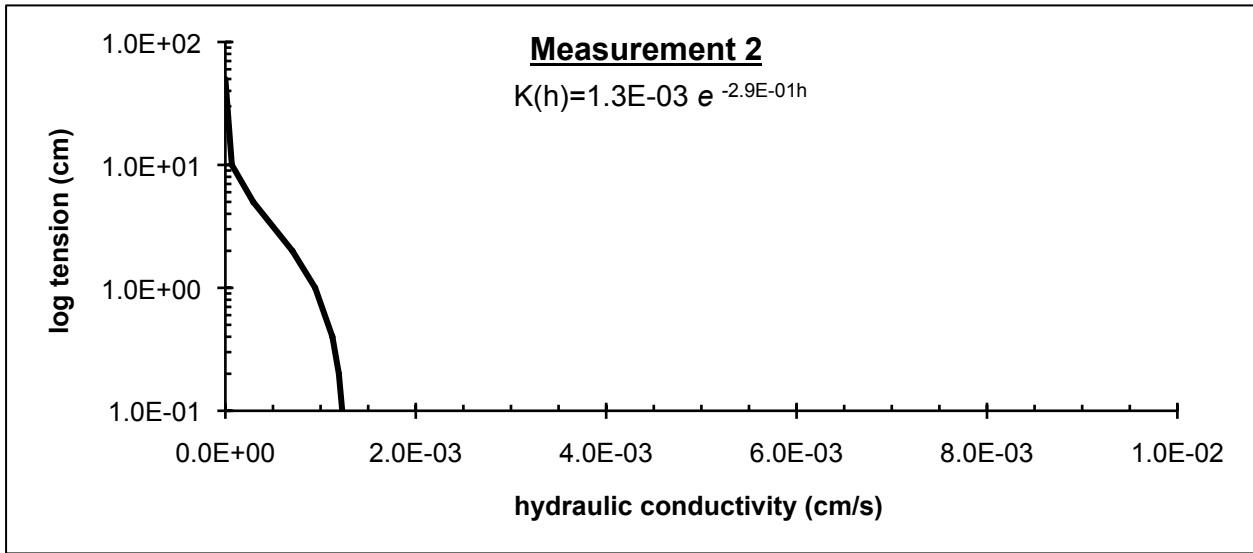

W37. Gentlebrook Rd at Silentglade Rd

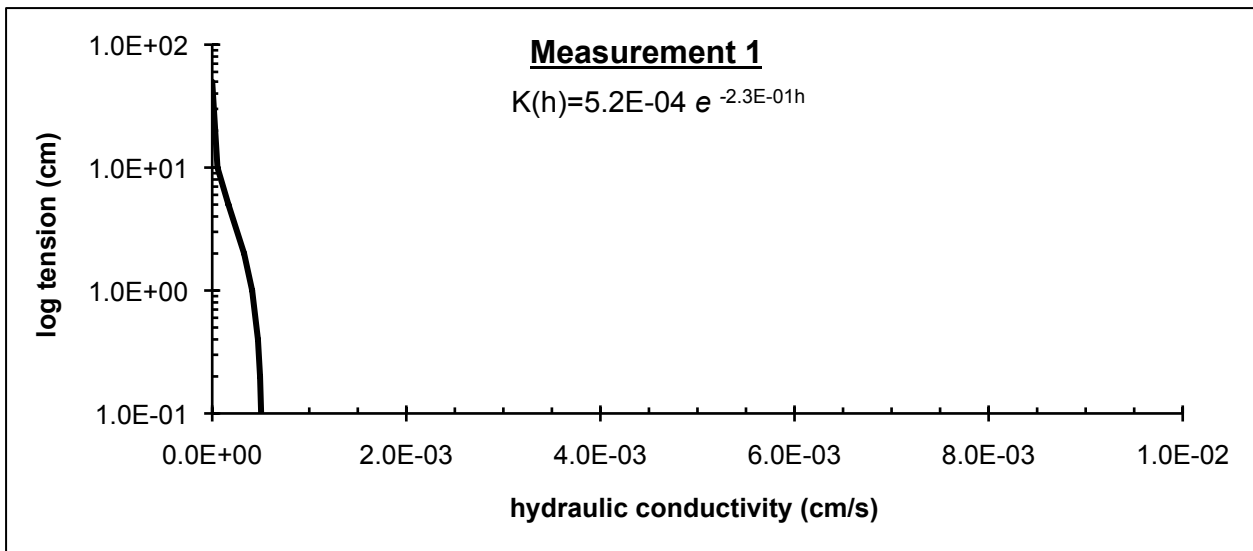
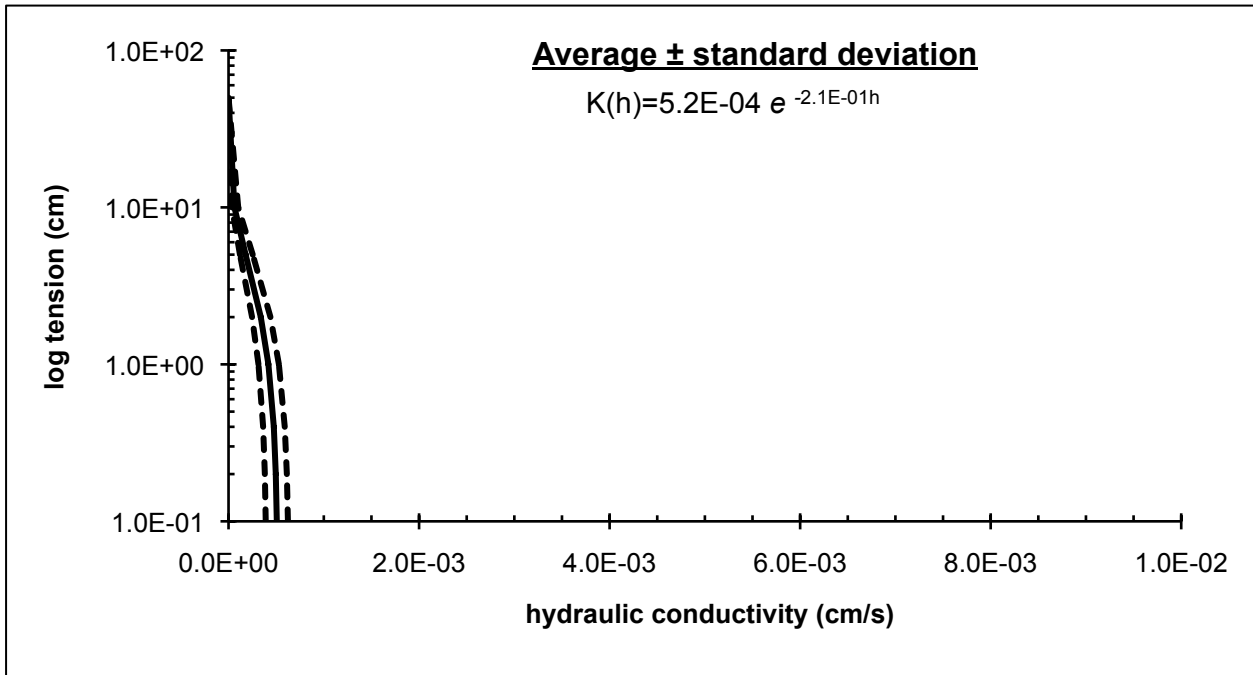

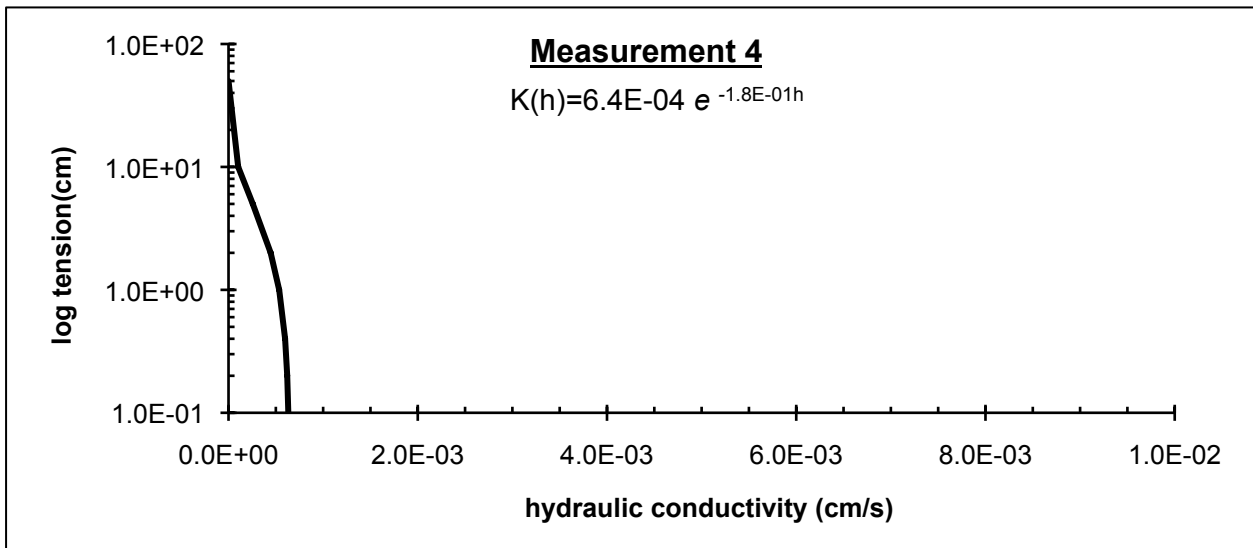
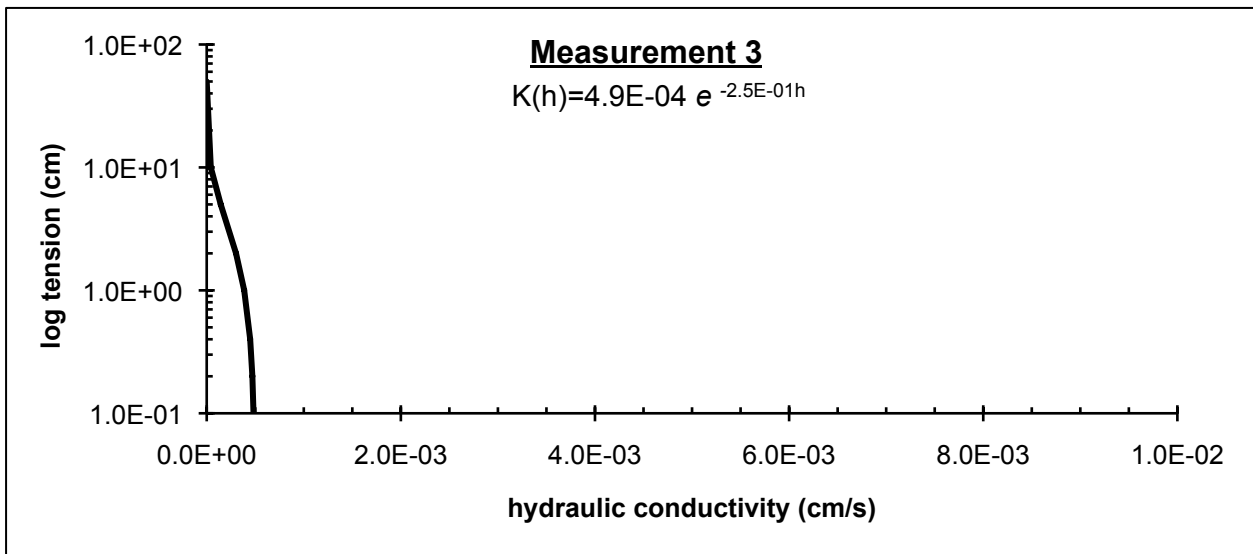
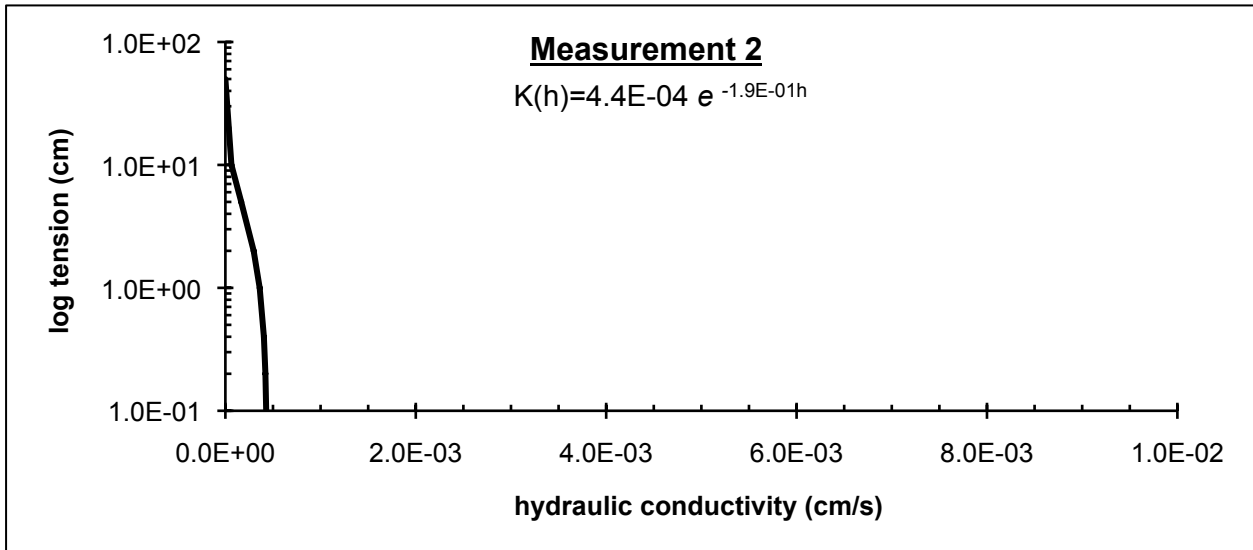

W38. SWR at Gwynnbrook Ave

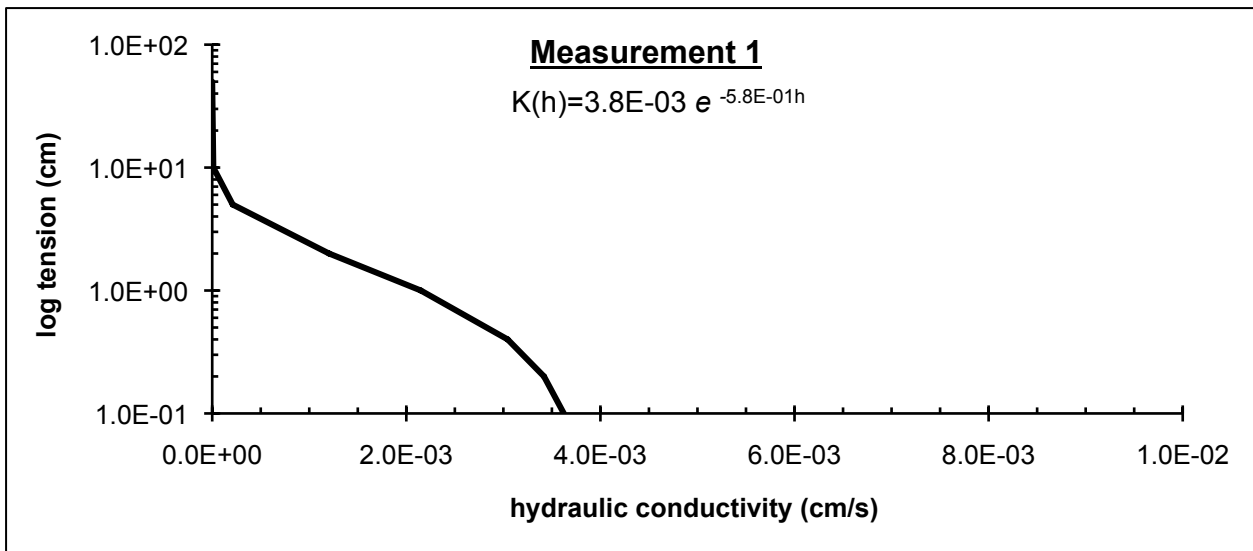
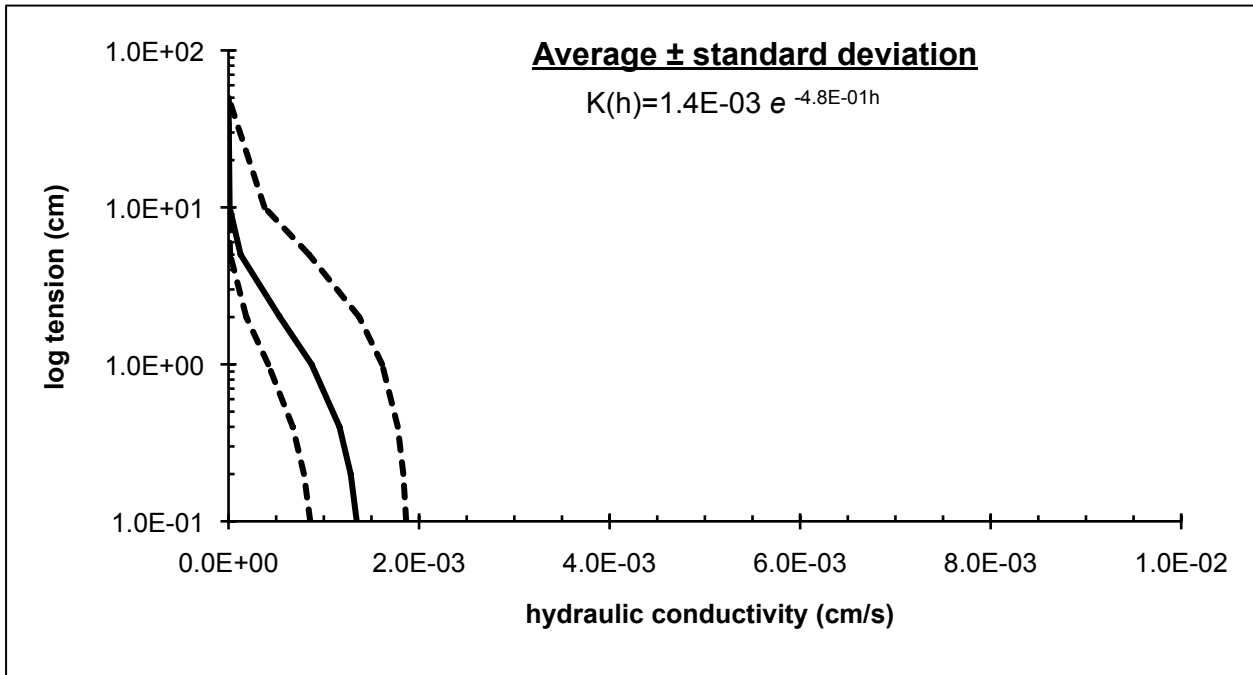

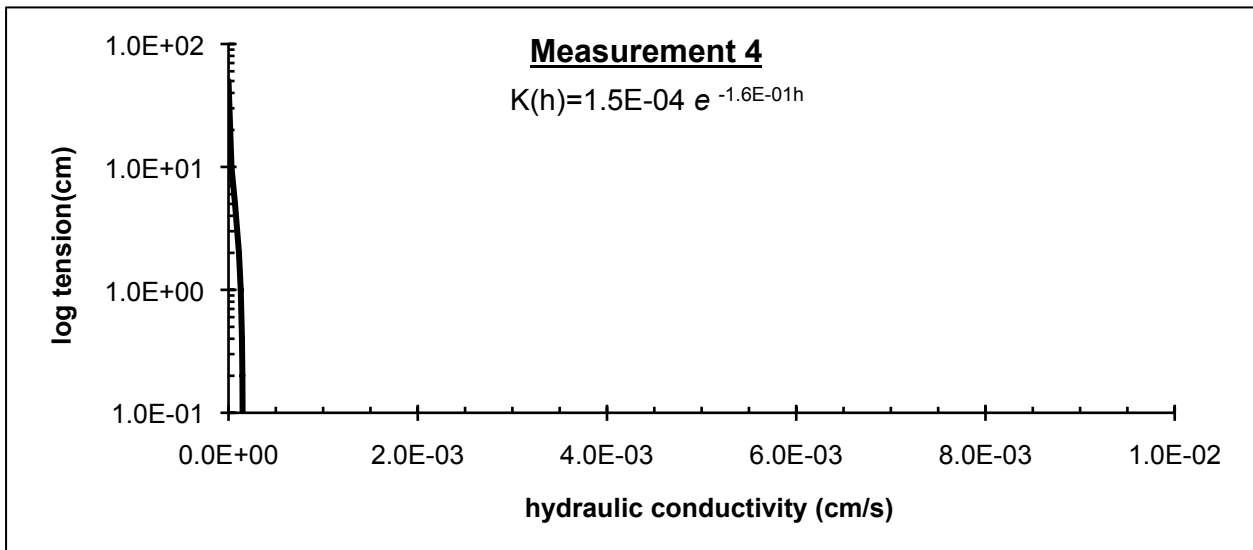
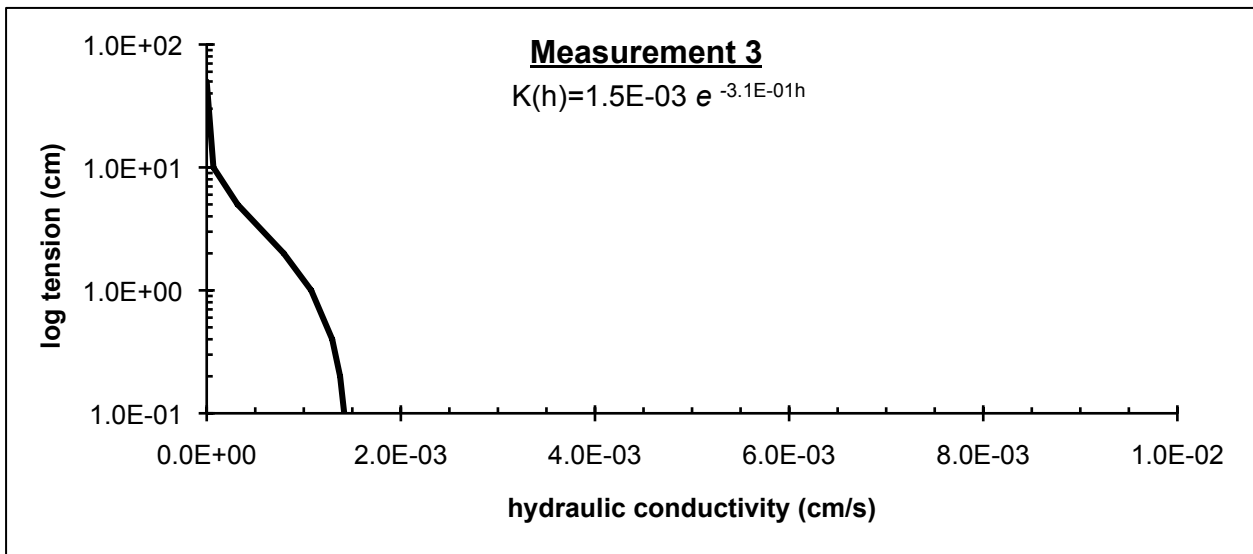
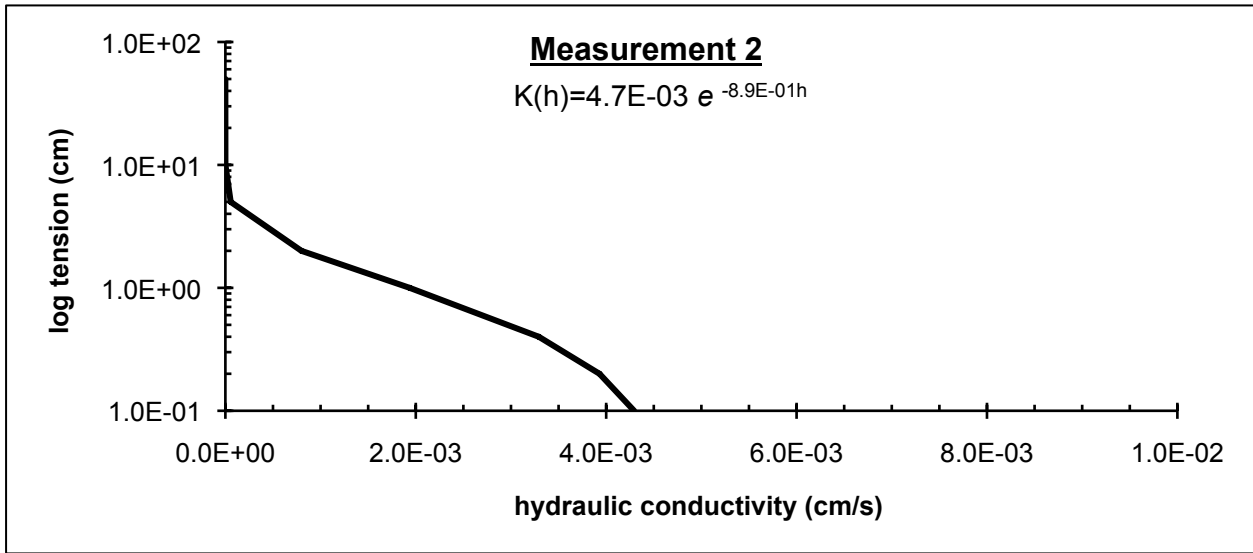

W40. Roaches Run Park

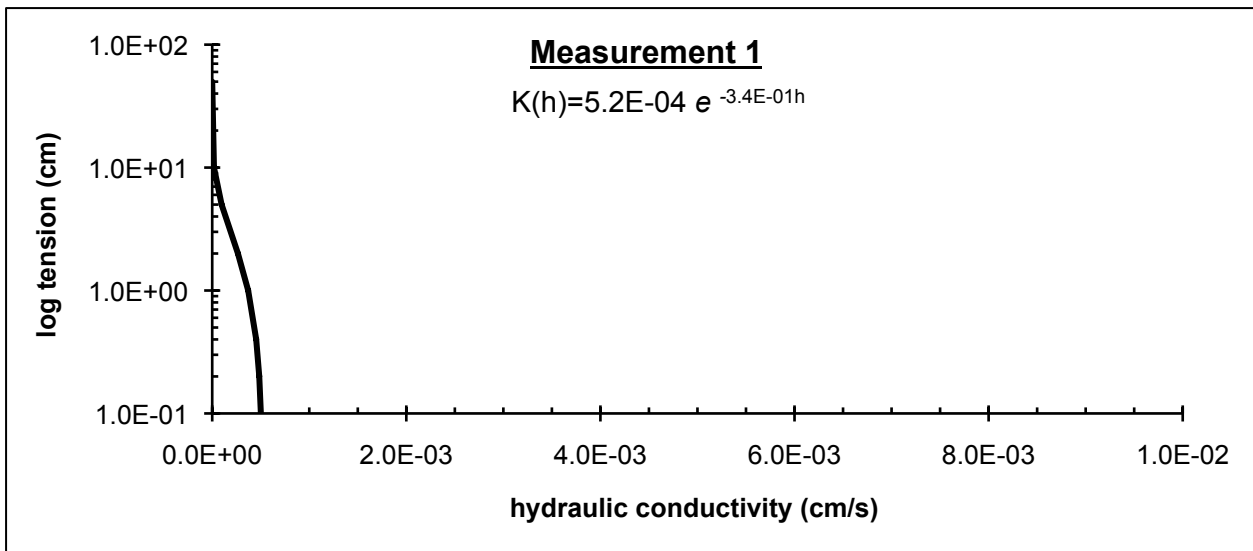
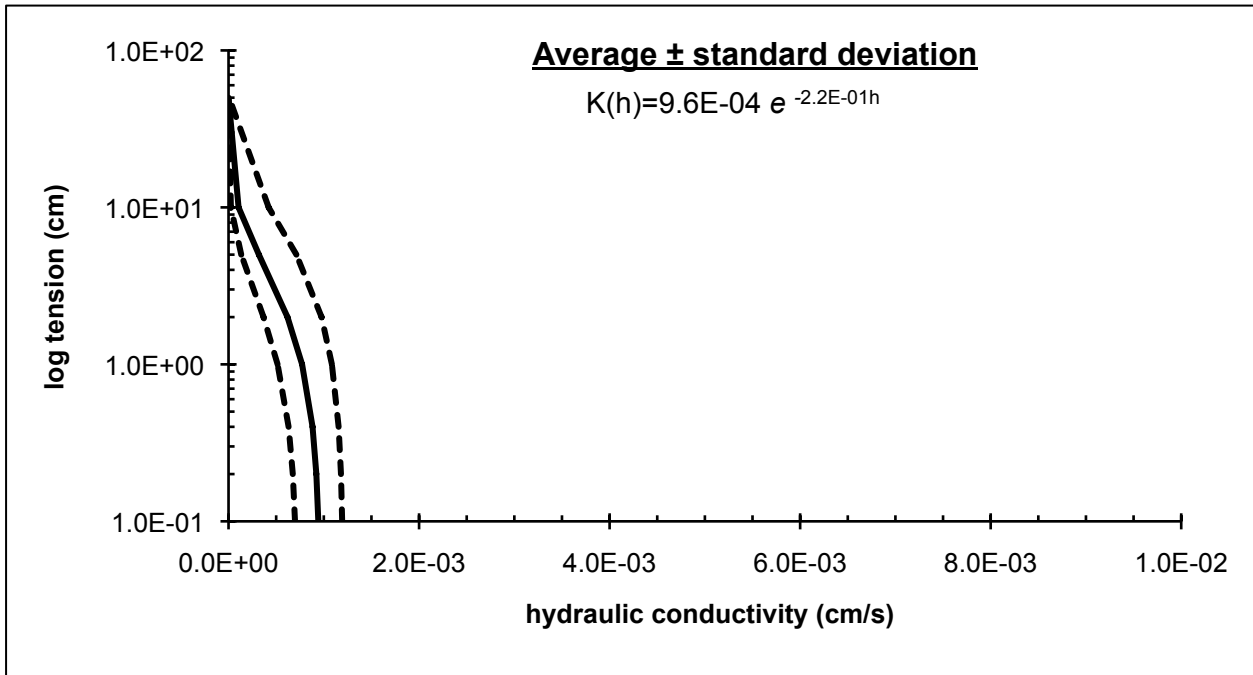

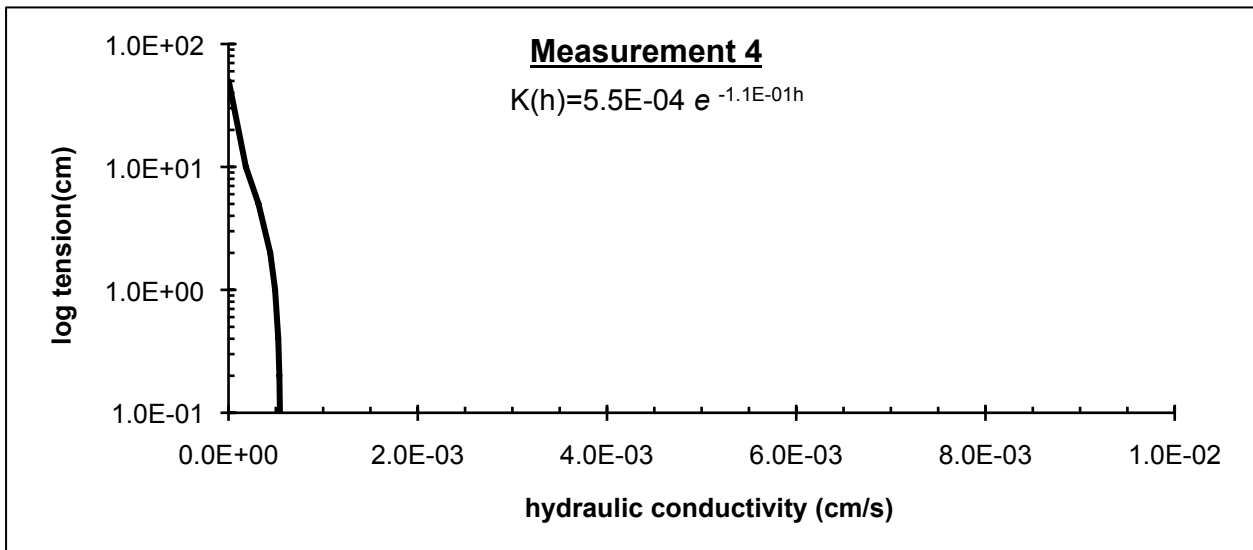
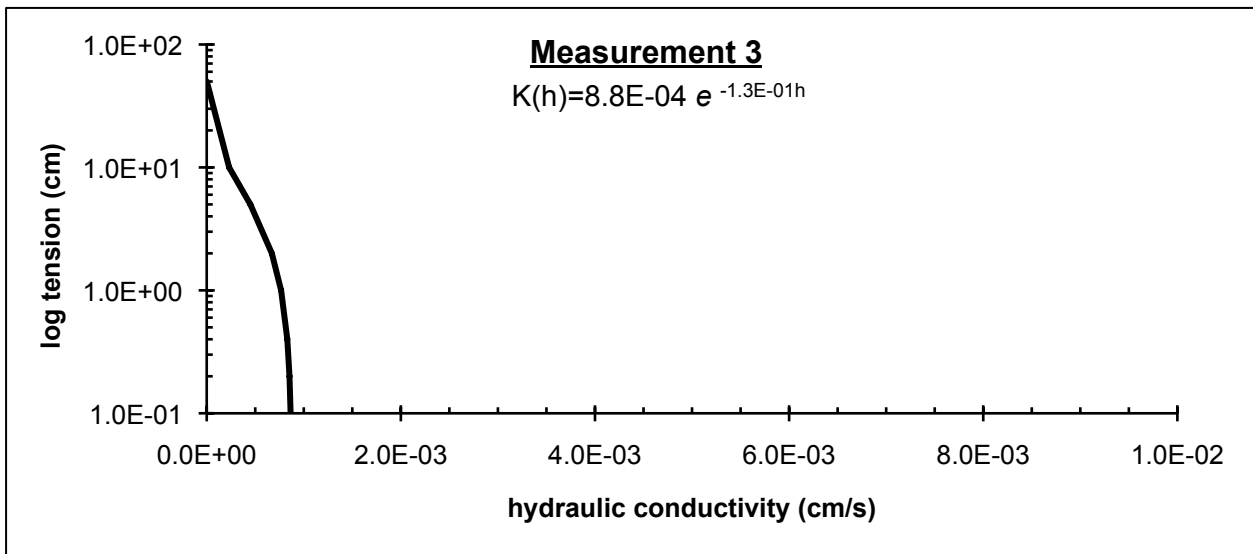
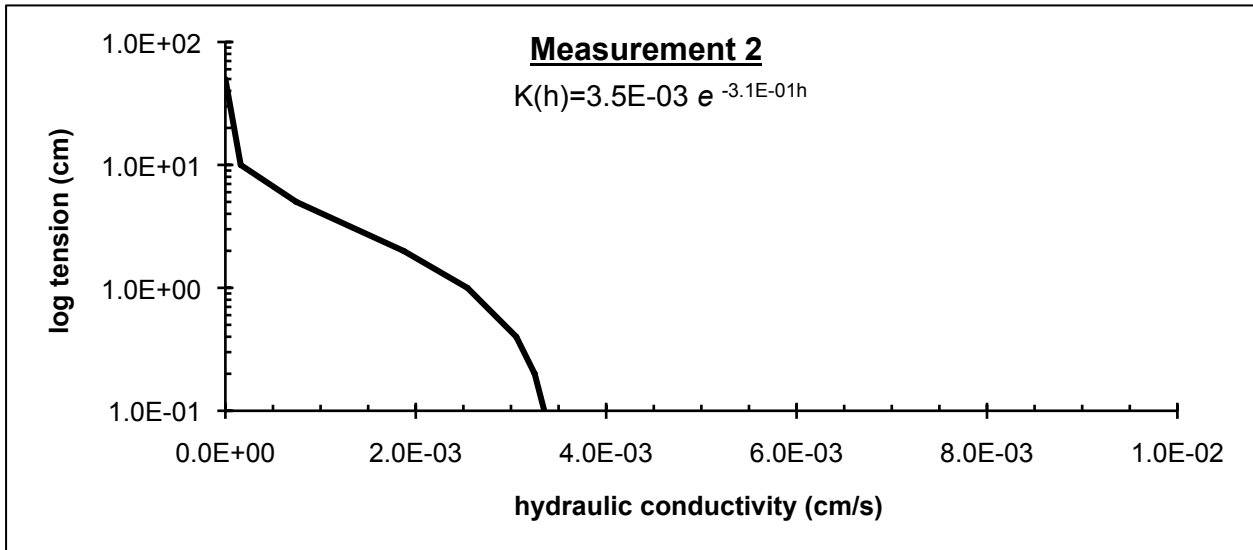

W41. SWR at Long Lake Rd

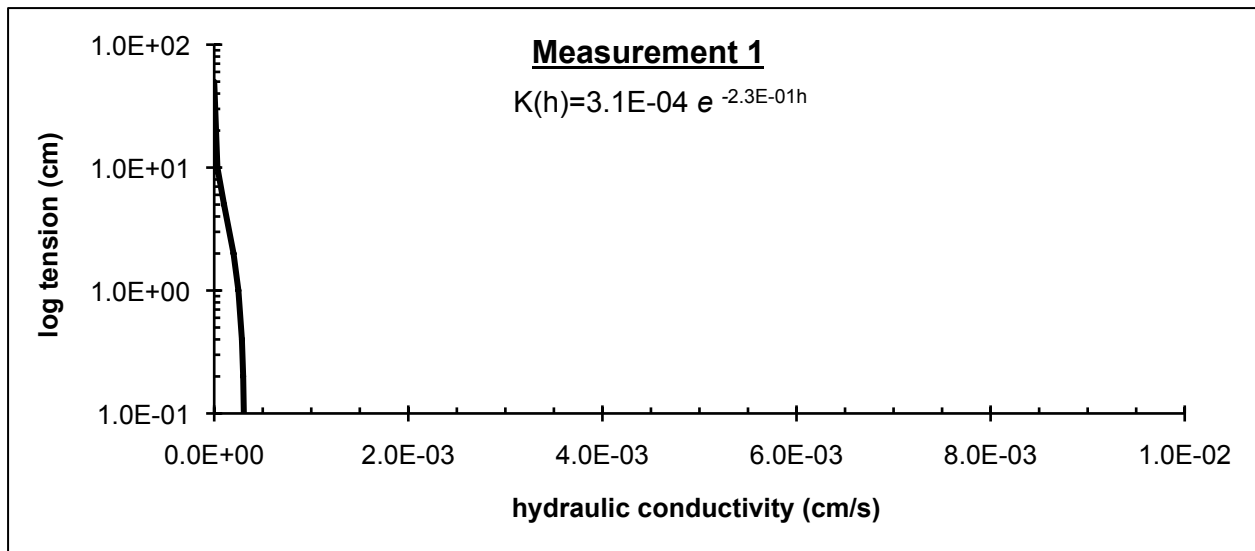
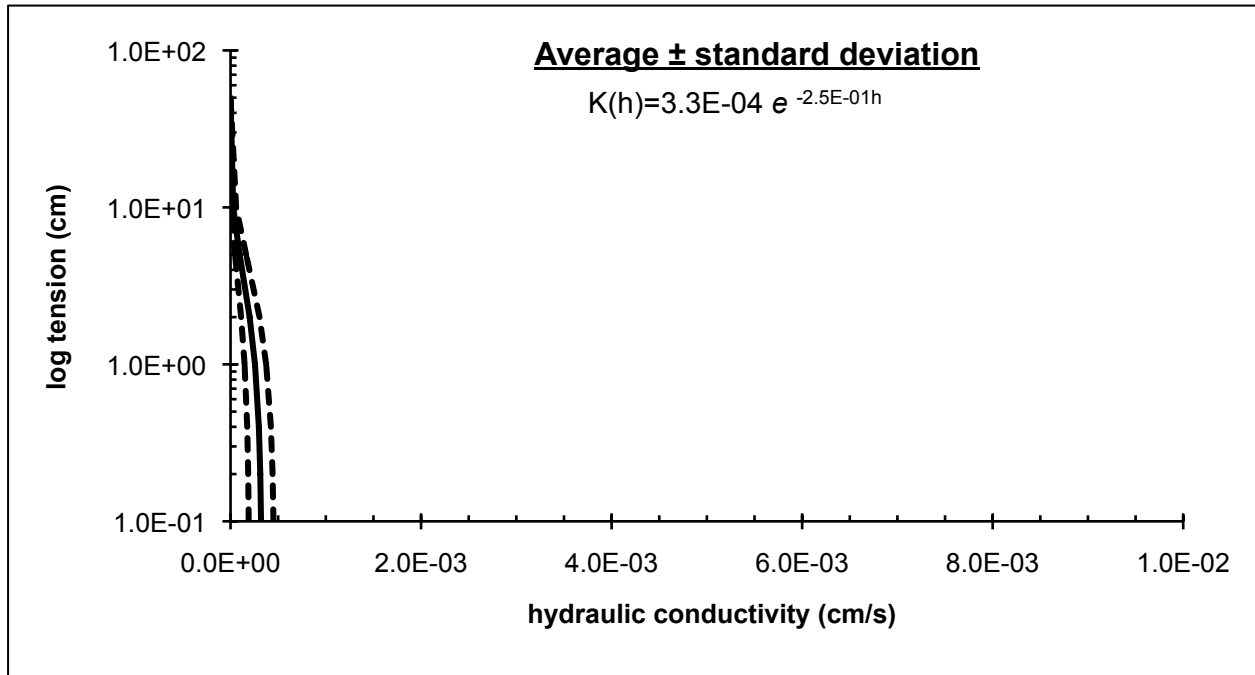

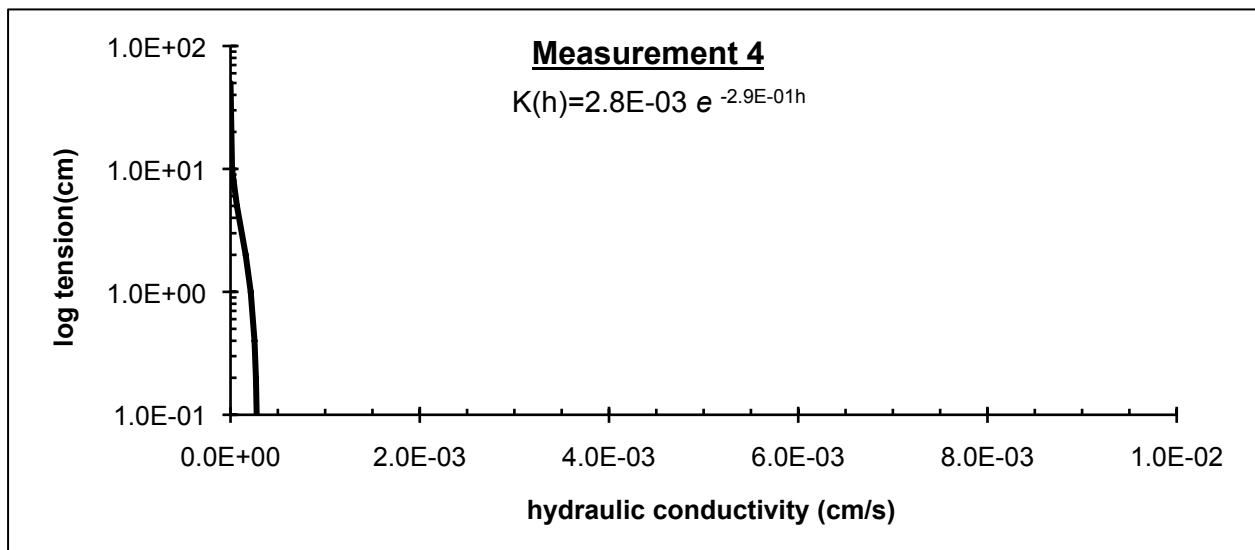
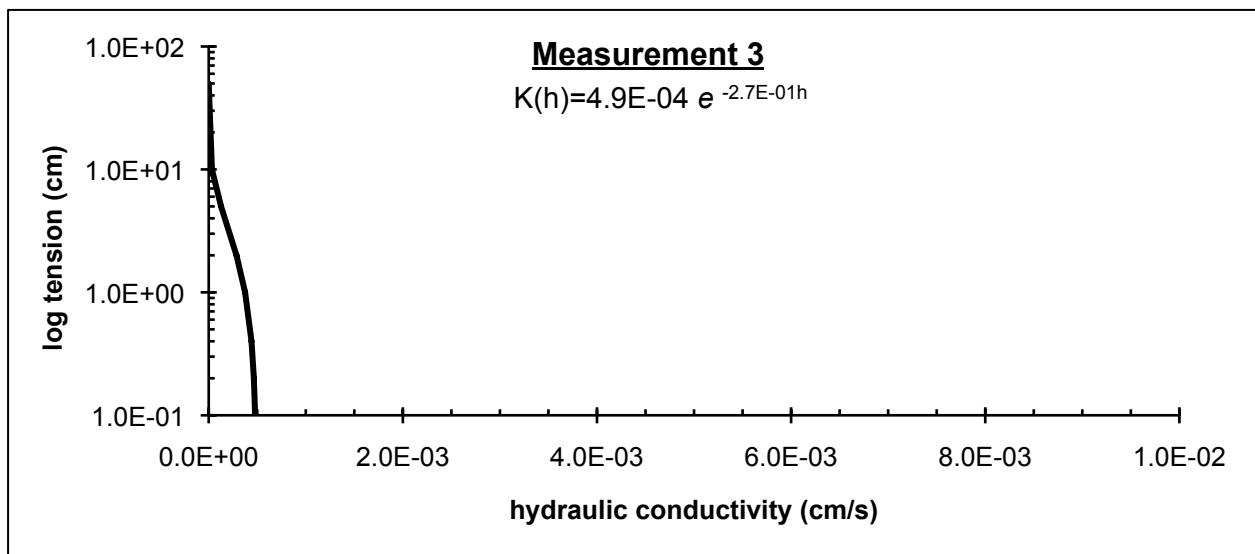
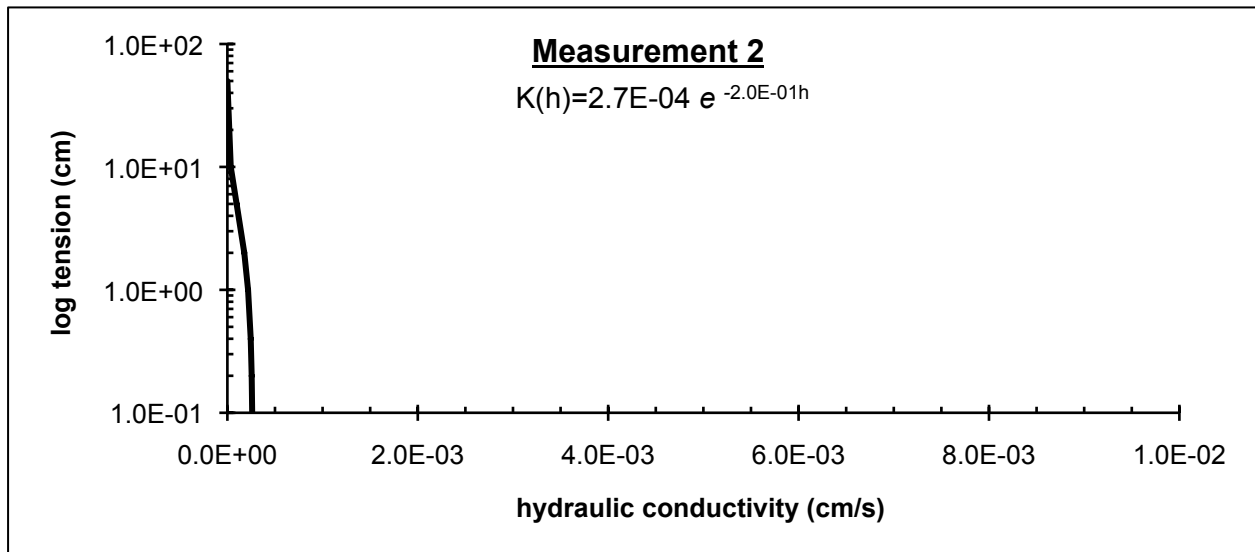

W42. Chatsworth School

